

FEATURES

- PLL generated or direct master clock
- Low EMI design
- DAC with 110 dB dynamic range and SNR
- 96 dB THD + N
- 3.3 V single supply
- Tolerance for 5 V logic inputs
- Supports 24 bits and 8 kHz to 192 kHz sample rates
- Differential DAC output
- Log volume control with autoramp function
- SPI® controllable for flexibility
- Software-controllable clickless mute
- Software power-down
- Right-justified, left-justified, I²S, and TDM modes
- Master and slave modes up to 16-channel input/output
- 64-lead LQFP
- Qualified for automotive applications

APPLICATIONS

- Automotive audio systems
- Home Theater Systems
- Set-top boxes
- Digital audio effects processors

GENERAL DESCRIPTION

The AD1933 is a high performance, single chip that provides eight digital-to-analog converters (DACs) with differential output using the Analog Devices, Inc., patented multibit sigma-delta (Σ - Δ) architecture. An SPI port is included, allowing a microcontroller to adjust volume and many other parameters. The AD1933 operates from 3.3 V digital and analog supplies. The AD1933 is available in a 64-lead (differential output) LQFP. Other members of this family include a single-ended DAC output version.

The AD1933 is designed for low EMI. This consideration is apparent in both the system and circuit design architectures. By using the on-board PLL to derive the master clock from the LR clock or from an external crystal, the AD1933 eliminates the need for a separate high frequency master clock and can also be used with a suppressed bit clock. The DACs are designed using the latest Analog Devices continuous time architectures to further minimize EMI. By using 3.3 V supplies, power consumption is minimized, further reducing emissions.

FUNCTIONAL BLOCK DIAGRAM

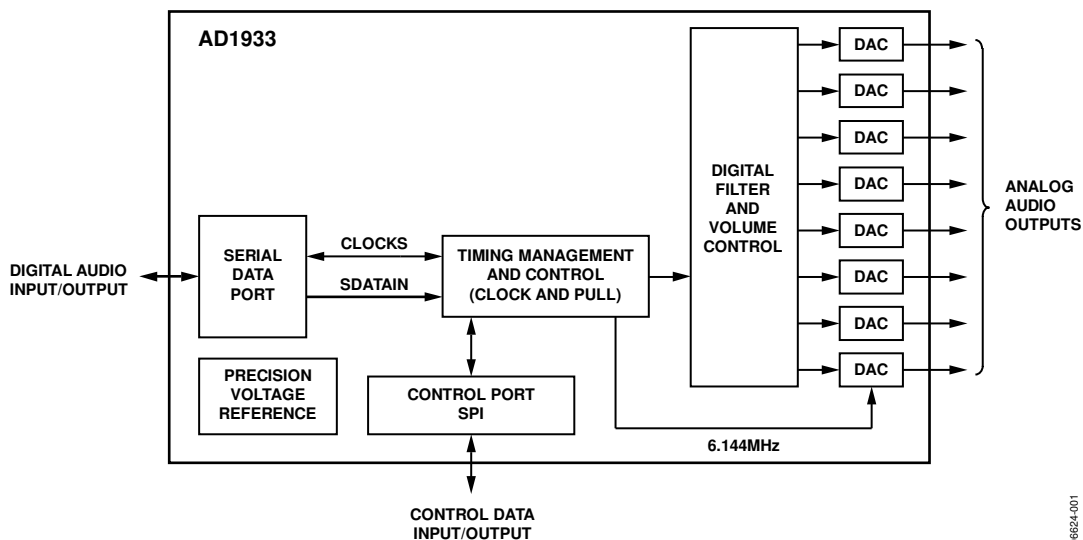

Figure 1.

06624-001

TABLE OF CONTENTS

Features	1	Digital-to-Analog Converters (DACs).....	11
Applications.....	1	Clock Signals.....	11
General Description	1	Reset and Power-Down	11
Functional Block Diagram	1	Serial Control Port	12
Revision History	2	Power Supply and Voltage Reference.....	13
Specifications.....	3	Serial Data Ports—Data Format.....	13
Test Conditions.....	3	Time-Division Multiplexed (TDM) Modes.....	13
Analog Performance Specifications	3	Daisy-Chain Mode	15
Crystal Oscillator Specifications.....	4	Control Registers	19
Digital Input/Output Specifications.....	4	Definitions.....	19
Power Supply Specifications.....	5	PLL and Clock Control Registers.....	19
Digital Filters.....	5	DAC Control Registers.....	20
Timing Specifications	6	Auxiliary TDM Port Control Registers	22
Absolute Maximum Ratings.....	7	Additional Modes.....	23
Thermal Resistance	7	Application Circuits	24
ESD Caution.....	7	Outline Dimensions	25
Pin Configuration and Function Descriptions.....	8	Ordering Guide	25
Typical Performance Characteristics	10	Automotive Products	25
Theory of Operation	11		
REVISION HISTORY			
2/13—Rev. D to Rev. E		1/11—Rev. A to Rev. B	
Changes to t_{CLH} Comments, Table 7	6	Changes to Features	1
Changes to Serial Control Port Section	12	Change to Table Summary, Table 2 and	
10/11—Rev. C to Rev. D		Table Summary, Table 4.....	4
Changes to Pin 14 in Figure 2 and Table 10.....	8	Changes to Table Summary, Table 7	6
Changes to Ordering Guide	25	9/09—Rev. 0 to Rev. A	
Added Automotive Products Section.....	25	Change to Title.....	1
7/11—Rev. B to Rev. C		Change to Table 10	9
Deleted Reference to I^2C	Throughout	Change to Power Supply and Voltage Reference Section.....	13
Changes to Table 10, DSDATAx/AUXDATA1 Pin		Updated Outline Dimensions	25
Descriptions	8	Changes to Ordering Guide	25
		10/07—Revision 0: Initial Version	

SPECIFICATIONS

TEST CONDITIONS

Performance of all channels is identical, exclusive of the interchannel gain mismatch and interchannel phase deviation specifications.

Supply voltages (AVDD, DVDD)	3.3 V
Temperature range ¹	As specified in Table 1 and Table 2
Master clock	12.288 MHz (48 kHz f_s , $256 \times f_s$ mode)
Input sample rate	48 kHz
Measurement bandwidth	20 Hz to 20 kHz
Word width	24 bits
Load capacitance (digital output)	20 pF
Load current (digital output)	± 1 mA or 1.5 k Ω to $\frac{1}{2}$ DVDD supply
Input voltage high	2.0 V
Input voltage low	0.8 V

¹ Functionally guaranteed at -40°C to $+125^\circ\text{C}$ case temperature.

ANALOG PERFORMANCE SPECIFICATIONS

Specifications guaranteed at an ambient temperature of 25°C .

Table 1.

Parameter	Test Conditions/Comments	Min	Typ	Max	Unit
DIGITAL-TO-ANALOG CONVERTERS					
Dynamic Range	20 Hz to 20 kHz, -60 dB input				
No Filter (RMS)		102	107		dB
With A-Weighted Filter (RMS)		105	110		dB
With A-Weighted Filter (Avg)			112		dB
Total Harmonic Distortion + Noise	0 dBFS				
Differential Version	Two channels running		-96		dB
	Eight channels running		-86	-76	dB
Full-Scale Output Voltage			1.76 (4.96)		V rms (V p-p)
Gain Error		-10		$+10$	%
Interchannel Gain Mismatch		-0.2		$+0.2$	dB
Offset Error		-25	-6	$+25$	mV
Gain Drift		-30		$+30$	ppm/ $^\circ\text{C}$
Interchannel Isolation			100		dB
Interchannel Phase Deviation			0		Degrees
Volume Control Step			0.375		dB
Volume Control Range			95		dB
De-emphasis Gain Error				± 0.6	dB
Output Resistance at Each Pin			100		Ω
REFERENCE					
Internal Reference Voltage	FILTR pin		1.50		V
External Reference Voltage	FILTR pin	1.32	1.50	1.68	V
Common-Mode Reference Output	CM pin		1.50		V
REGULATOR					
Input Supply Voltage	VSUPPLY pin	4.5	5.0	5.5	V
Regulated Supply Voltage	VSENSE pin	3.19	3.37	3.55	V

Specifications measured at a case temperature of 125°C.

Table 2.

Parameter	Test Conditions/Comments	Min	Typ	Max	Unit
DIGITAL-TO-ANALOG CONVERTERS					
Dynamic Range	20 Hz to 20 kHz, –60 dB input				
No Filter (RMS)		101	107		dB
With A-Weighted Filter (RMS)		104	110		dB
With A-Weighted Filter (Average)			112		dB
Total Harmonic Distortion + Noise	0 dBFS				
Differential Version	Two channels running		–94		dB
	Eight channels running		–86	–70	dB
Full-Scale Output Voltage			1.76 (4.96)		V rms (V p-p)
Gain Error		–10		+10	%
Interchannel Gain Mismatch		–0.2		+0.2	dB
Offset Error		–25	–6	+25	mV
Gain Drift		–30		+30	ppm/°C
REFERENCE					
Internal Reference Voltage	FILTR pin		1.50		V
External Reference Voltage	FILTR pin	1.32	1.50	1.68	V
Common-Mode Reference Output	CM pin		1.50		V
REGULATOR					
Input Supply Voltage	VSUPPLY pin	4.5	5.0	5.5	V
Regulated Supply Voltage	VSENSE pin	3.2	3.43	3.65	V

CRYSTAL OSCILLATOR SPECIFICATIONS

Table 3.

Parameter	Min	Typ	Max	Unit
Transconductance		3.5		mmhos

DIGITAL INPUT/OUTPUT SPECIFICATIONS

–40°C < T_c < +125°C, DVDD = 3.3 V ± 10%.

Table 4.

Parameter	Test Conditions/Comments	Min	Typ	Max	Unit
High Level Input Voltage (V _{IH})		2.0			V
High Level Input Voltage (V _{IH})	MCLKI/XI pin	2.2			V
Low Level Input Voltage (V _{IL})				0.8	V
Input Leakage	I _{IH} @ V _{IH} = 2.4 V			10	μA
	I _{IL} @ V _{IL} = 0.8 V			10	μA
High Level Output Voltage (V _{OH})	I _{OH} = 1 mA	DVDD – 0.60			V
Low Level Output Voltage (V _{OL})	I _{OL} = 1 mA			0.4	V
Input Capacitance				5	pF

POWER SUPPLY SPECIFICATIONS

Table 5.

Parameter	Test Conditions/Comments	Min	Typ	Max	Unit
SUPPLIES					
Voltage	DVDD	3.0	3.3	3.6	V
	AVDD	3.0	3.3	3.6	V
	VSUPPLY	4.5	5.0	5.5	V
Digital Current	Master clock = 256 f _s				
Normal Operation	f _s = 48 kHz		56		mA
	f _s = 96 kHz		65		mA
	f _s = 192 kHz		95		mA
Power-Down	f _s = 48 kHz to 192 kHz		2.0		mA
Analog Current					
Normal Operation			74		mA
Power-Down			23		mA
DISSIPATION					
Operation	Master clock = 256 f _s , 48 kHz				
All Supplies			429		mW
Digital Supply			185		mW
Analog Supply			244		mW
Power-Down, All Supplies			83		mW
POWER SUPPLY REJECTION RATIO					
Signal at Analog Supply Pins	1 kHz, 200 mV p-p 20 kHz, 200 mV p-p		50 50		dB dB

DIGITAL FILTERS

Table 6.

Parameter	Mode	Factor	Min	Typ	Max	Unit
DAC INTERPOLATION FILTER						
Pass Band	48 kHz mode, typical @ 48 kHz	0.4535 f _s		22		kHz
	96 kHz mode, typical @ 96 kHz	0.3646 f _s	35			kHz
	192 kHz mode, typical @ 192 kHz	0.3646 f _s		70		kHz
Pass-Band Ripple	48 kHz mode, typical @ 48 kHz				±0.01	dB
	96 kHz mode, typical @ 96 kHz				±0.05	dB
	192 kHz mode, typical @ 192 kHz				±0.1	dB
Transition Band	48 kHz mode, typical @ 48 kHz	0.5 f _s		24		kHz
	96 kHz mode, typical @ 96 kHz	0.5 f _s		48		kHz
	192 kHz mode, typical @ 192 kHz	0.5 f _s		96		kHz
Stop Band	48 kHz mode, typical @ 48 kHz	0.5465 f _s		26		kHz
	96 kHz mode, typical @ 96 kHz	0.6354 f _s		61		kHz
	192 kHz mode, typical @ 192 kHz	0.6354 f _s		122		kHz
Stop-Band Attenuation	48 kHz mode, typical @ 48 kHz		70			dB
	96 kHz mode, typical @ 96 kHz		70			dB
	192 kHz mode, typical @ 192 kHz		70			dB
Group Delay	48 kHz mode, typical @ 48 kHz	25/f _s		521		μs
	96 kHz mode, typical @ 96 kHz	11/f _s		115		μs
	192 kHz mode, typical @ 192 kHz	8/f _s		42		μs

TIMING SPECIFICATIONS

$-40^{\circ}\text{C} < T_c < +125^{\circ}\text{C}$, $\text{DVDD} = 3.3 \text{ V} \pm 10\%$.

Table 7.

Parameter	Condition	Comments	Min	Max	Unit
INPUT MASTER CLOCK (MCLK) AND RESET					
t_{MH}	MCLK duty cycle	DAC clock source = PLL clock @ 256 f_s , 384 f_s , 512 f_s , and 768 f_s	40	60	%
t_{MH}		DAC clock source = direct MCLK @ 512 f_s (bypass on-chip PLL)	40	60	%
f_{MCLK}	MCLK frequency	PLL mode, 256 f_s reference	6.9	13.8	MHz
f_{MCLK}		Direct 512 f_s mode		27.6	MHz
t_{PDR}	$\overline{\text{RST}}$ low		15		ns
t_{PDRR}	$\overline{\text{RST}}$ recovery	Reset to active output	4096		t_{MCLK}
PLL					
Lock Time	MCLK and LR clock input			10	ms
256 f_s VCO Clock, Output Duty Cycle MCLKO/XO Pin			40	60	%
SPI PORT					
t_{CCH}	CCLK high	See Figure 9	35		ns
t_{CCL}	CCLK low		35		ns
f_{CCLK}	CCLK frequency	$f_{CCLK} = 1/t_{CCP}$, only t_{CCP} shown in Figure 9		10	MHz
t_{CDS}	CIN setup	To CCLK rising	10		ns
t_{CDH}	CIN hold	From CCLK rising	10		ns
t_{CLS}	$\overline{\text{CLATCH}}$ setup	To CCLK rising	10		ns
t_{CLH}	$\overline{\text{CLATCH}}$ hold	From CCLK rising	10		ns
t_{CLHIGH}	$\overline{\text{CLATCH}}$ high	Not shown in Figure 9	10		ns
t_{COE}	COUT enable	From CCLK falling		30	ns
t_{COD}	COUT delay	From CCLK falling		30	ns
t_{COH}	COUT hold	From CCLK falling, not shown in Figure 9	30		ns
t_{COTS}	COUT tristate	From CCLK falling		30	ns
DAC SERIAL PORT					
t_{DBH}	DBCLK high	See Figure 16	10		ns
t_{DBL}	DBCLK low	Slave mode	10		ns
t_{DLS}	DLRCLK setup	To DBCLK rising, slave mode	10		ns
t_{DLH}	DLRCLK hold	From DBCLK rising, slave mode	5		ns
t_{DLS}	DLRCLK skew	From DBCLK falling, master mode	-8	+8	ns
t_{DDS}	DSDATA setup	To DBCLK rising	10		ns
t_{DDH}	DSDATA hold	From DBCLK rising	5		ns
AUXTDM SERIAL PORT					
t_{ABH}	AUXTDMBCLK high	See Figure 17	10		ns
t_{ABL}	AUXTDMBCLK low	Slave mode	10		ns
t_{ALS}	AUXTDMLRCLK setup	To AUXTDMBCLK rising, slave mode	10		ns
t_{ALH}	AUXTDMLRCLK hold	From AUXTDMBCLK rising, slave mode	5		ns
t_{ALS}	AUXTDMLRCLK skew	From AUXTDMBCLK falling, master mode	-8	+8	ns
t_{DDS}	DSDATA setup	To AUXTDMBCLK, not shown in Figure 17	10		ns
t_{DDH}	DSDATA hold	From AUXTDMBCLK rising, not shown in Figure 17	5		ns
AUXILIARY INTERFACE					
t_{DXDD}	AUXDATA delay	From AUXBCLK falling		18	ns
t_{XBH}	AUXBCLK high		10		ns
t_{XBL}	AUXBCLK low		10		ns
t_{DLS}	AUXLRCLK setup	To AUXBCLK rising	10		ns
t_{DLH}	AUXLRCLK hold	From AUXBCLK rising	5		ns

ABSOLUTE MAXIMUM RATINGS

Table 8.

Parameter	Rating
Analog (AVDD)	−0.3 V to +3.6 V
Digital (DVDD)	−0.3 V to +3.6 V
VSUPPLY	−0.3 V to +6.0 V
Input Current (Except Supply Pins)	±20 mA
Analog Input Voltage (Signal Pins)	−0.3 V to AVDD + 0.3 V
Digital Input Voltage (Signal Pins)	−0.3 V to DVDD + 0.3 V
Operating Temperature Range (Case)	−40°C to +125°C
Storage Temperature Range	−65°C to +150°C

Stresses above those listed under Absolute Maximum Ratings may cause permanent damage to the device. This is a stress rating only; functional operation of the device at these or any other conditions above those indicated in the operational section of this specification is not implied. Exposure to absolute maximum rating conditions for extended periods may affect device reliability.

THERMAL RESISTANCE

θ_{JA} represents thermal resistance, junction-to-ambient;
 θ_{JC} represents thermal resistance, junction-to-case. All characteristics are for a 4-layer board.

Table 9. Thermal Resistance

Package Type	θ_{JA}	θ_{JC}	Unit
64-Lead LQFP	47	11.1	°C/W

ESD CAUTION



ESD (electrostatic discharge) sensitive device. Charged devices and circuit boards can discharge without detection. Although this product features patented or proprietary protection circuitry, damage may occur on devices subjected to high energy ESD. Therefore, proper ESD precautions should be taken to avoid performance degradation or loss of functionality.

PIN CONFIGURATION AND FUNCTION DESCRIPTIONS

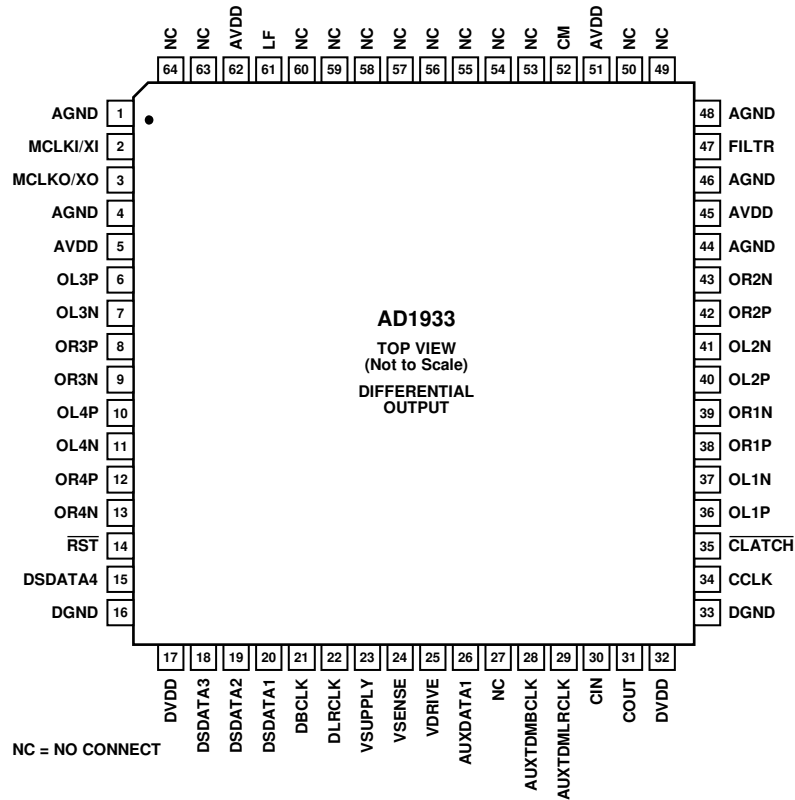

Figure 2. Pin Configuration

Table 10. Pin Function Descriptions

Pin No.	Input/Output	Mnemonic	Description
1	I	AGND	Analog Ground.
2	I	MCLKI/XI	Master Clock Input/Crystal Oscillator Input.
3	O	MCLKO/XO	Master Clock Output/Crystal Oscillator Output.
4	I	AGND	Analog Ground.
5	I	AVDD	Analog Power Supply. Connect to analog 3.3 V supply.
6	O	OL3P	DAC 3 Left Positive Output.
7	O	OL3N	DAC 3 Left Negative Output.
8	O	OR3P	DAC 3 Right Positive Output.
9	O	OR3N	DAC 3 Right Negative Output.
10	O	OL4P	DAC 4 Left Positive Output.
11	O	OL4N	DAC 4 Left Negative Output.
12	O	OR4P	DAC 4 Right Positive Output.
13	O	OR4N	DAC 4 Right Negative Output.
14	I	RST	Reset (Active Low).
15	I/O	DSDATA4	DAC Serial Data Input 4. Input to DAC4 data in/TDM DAC2 data out (dual-line mode)/AUX DAC2 data out (to external DAC2).
16	I	DGND	Digital Ground.
17	I	DVDD	Digital Power Supply. Connect to digital 3.3 V supply.
18	I/O	DSDATA3	DAC Serial Data Input 3. Data input to DAC3 in/TDM DAC2 data in (dual-line mode)/AUX not used.
19	I/O	DSDATA2	DAC Serial Data Input 2. Data input to DAC2 data in/TDM DAC data out/AUX not used.
20	I	DSDATA1	DAC Serial Data Input 1. Data input to DAC1 data in/TDM DAC data in/AUX TDM data in.
21	I/O	DBCLK	Bit Clock for DACs. Regular stereo, TDM, or daisy-chain TDM mode.
22	I/O	DLRCLK	LR Clock for DACs. Regular stereo, TDM, or daisy-chain TDM mode.

Pin No.	Input/Output	Mnemonic	Description
23	I	VSUPPLY	5 V Input to Regulator, Emitter of Pass Transistor.
24	I	VSENSE	3.3 V Output of Regulator, Collector of Pass Transistor.
25	O	VDRIVE	Drive for Base of Pass Transistor.
26	O	AUXDATA1	AUX DAC1 data out (to external DAC1).
27, 49, 50, 63, 64		NC	No Connect.
28	I/O	AUXTDMCLK	Auxiliary Mode Only DAC TDM Bit Clock.
29	I/O	AUXTDMCLK	Auxiliary Mode Only DAC LR TDM Clock.
30	I	CIN	Control Data Input (SPI).
31	I/O	COUT	Control Data Output (SPI).
32	I	DVDD	Digital Power Supply. Connect to digital 3.3 V supply.
33	I	DGND	Digital Ground.
34	I	CCLK	Control Clock Input (SPI).
35	I	CLATCH	Latch Input for Control Data (SPI).
36	O	OL1P	DAC 1 Left Positive Output.
37	O	OL1N	DAC 1 Left Negative Output.
38	O	OR1P	DAC 1 Right Positive Output.
39	O	OR1N	DAC 1 Right Negative Output.
40	O	OL2P	DAC 2 Left Positive Output.
41	O	OL2N	DAC 2 Left Negative Output.
42	O	OR2P	DAC 2 Right Positive Output.
43	O	OR2N	DAC 2 Right Negative Output.
44	I	AGND	Analog Ground.
45	I	AVDD	Analog Power Supply. Connect to analog 3.3 V supply.
46	I	AGND	Analog Ground.
47	O	FILTR	Voltage Reference Filter Capacitor Connection. Bypass with 10 μ F 100 nF to AGND.
48	I	AGND	Analog Ground.
51	I	AVDD	Analog Power Supply. Connect to analog 3.3 V supply.
52	O	CM	Common-Mode Reference Filter Capacitor Connection. Bypass with 47 μ F 100 nF to AGND.
53 to 60	I	NC	Must Be Tied to Common Mode, Pin 52. Alternately, ac-couple these pins to ground.
61	O	LF	PLL Loop Filter, Return to AVDD.
62	I	AVDD	Analog Power Supply. Connect to analog 3.3 V supply.

TYPICAL PERFORMANCE CHARACTERISTICS

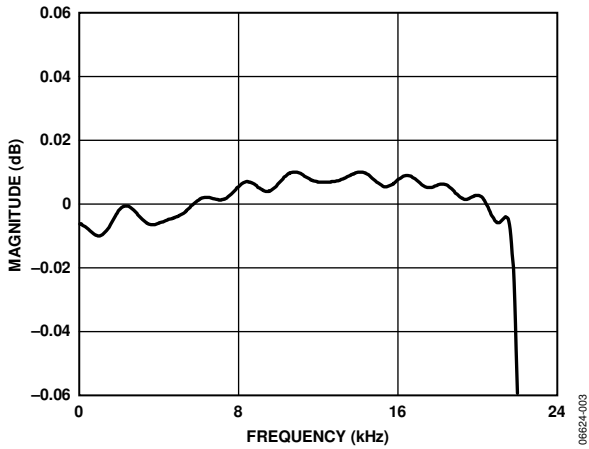

Figure 3. DAC Pass-Band Filter Response, 48 kHz

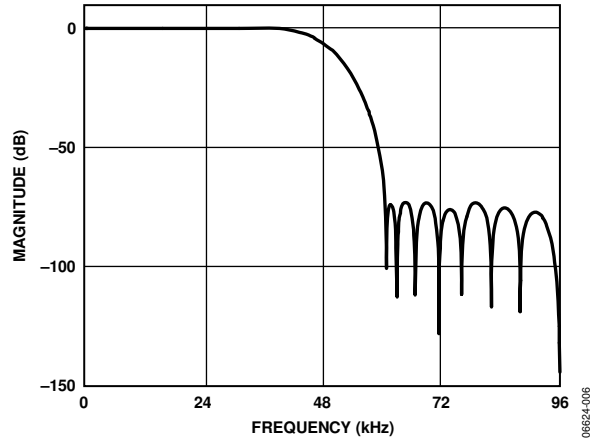

Figure 6. DAC Stop-Band Filter Response, 96 kHz

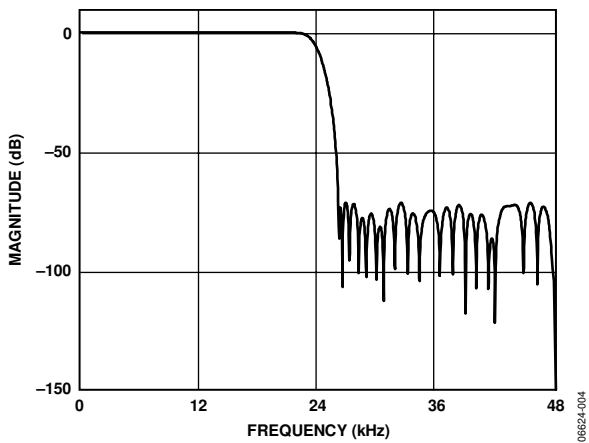

Figure 4. DAC Stop-Band Filter Response, 48 kHz

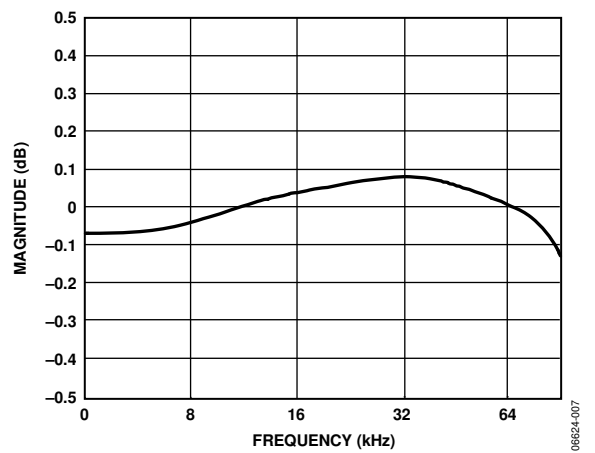

Figure 7. DAC Pass-Band Filter Response, 192 kHz

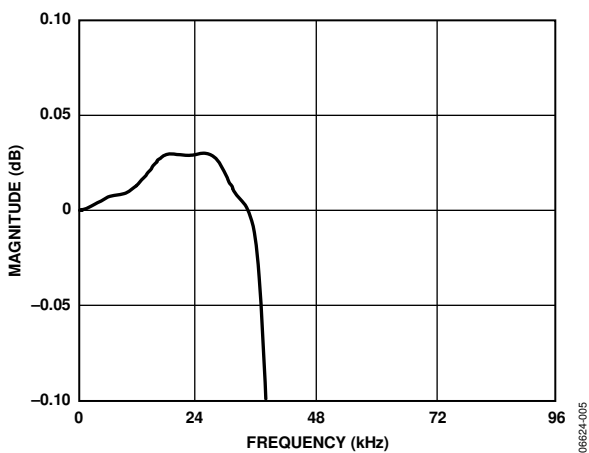

Figure 5. DAC Pass-Band Filter Response, 96 kHz

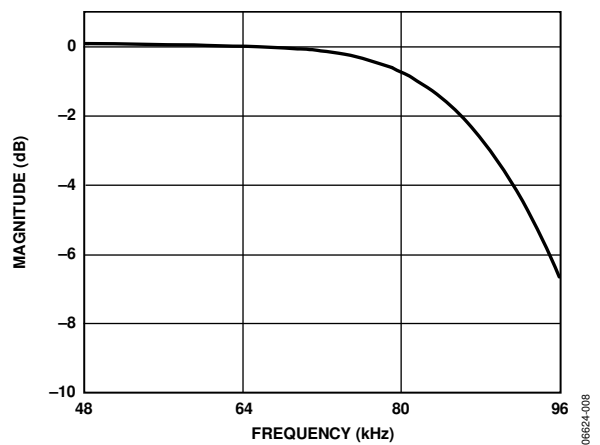

Figure 8. DAC Stop-Band Filter Response, 192 kHz

THEORY OF OPERATION

DIGITAL-TO-ANALOG CONVERTERS (DACs)

The AD1933 DAC channels are arranged as differential, four stereo pairs giving eight analog outputs for minimum external components. The DACs include on-board digital reconstruction filters with 70 dB stop-band attenuation and linear phase response, operating at an oversampling ratio of 4 (48 kHz or 96 kHz modes) or 2 (192 kHz mode). Each channel has its own independently programmable attenuator, adjustable in 255 steps in increments of 0.375 dB. Digital inputs are supplied through four serial data input pins (one for each stereo pair) and a common frame clock (DLRCLK) and bit clock (DBCLK). Alternatively, one of the TDM modes can be used to access up to 16 channels on a single TDM data line.

Each output pin has a nominal common-mode dc level of 1.5 V and swings ± 1.27 V for a 0 dBFS digital input signal. A third-order, external, low-pass filter is recommended to remove high frequency noise present on the output pins. The use of op amps with low slew rates or low bandwidths can cause high frequency noise and tones to fold down into the audio band; therefore, exercise care in selecting these components.

The voltage at CM, the common-mode reference pin, can be used to bias the external op amps that buffer the output signals (see the Power Supply and Voltage Reference section).

CLOCK SIGNALS

The on-chip, phase-locked loop (PLL) can be selected to reference the input sample rate from either of the LRCLK pins or 256, 384, 512, or 768 times the sample rate, referenced to the 48 kHz mode from the MCLKI/XI pin. The default at power-up is $256 \times f_s$ from MCLKI/XI pin. In 96 kHz mode, the master clock frequency stays at the same absolute frequency; therefore, the actual multiplication rate is divided by 2. In 192 kHz mode, the actual multiplication rate is divided by 4. For example, if a device in the AD1933 family is programmed in $256 \times f_s$ mode, the frequency of the master clock input is 256×48 kHz = 12.288 MHz. If the AD1933 is then switched to 96 kHz operation (by writing to the SPI port), the frequency of the master clock should remain at 12.288 MHz, which becomes $128 \times f_s$. In 192 kHz mode, this becomes $64 \times f_s$.

The internal clock for the DACs varies by mode: $512 \times f_s$ (48 kHz mode), $256 \times f_s$ (96 kHz mode), or $128 \times f_s$ (192 kHz mode). By default, the on-board PLL generates this internal master clock from an external clock. A direct $512 \times f_s$ (referenced to 48 kHz mode) master clock can be used for DACs if selected in the PLL and Clock Control 1 register.

The PLL can be powered down in the PLL and Clock Control 0 register. To ensure reliable locking when changing PLL modes, or if the reference clock is unstable at power-on, power down the PLL and power it back up when the reference clock has stabilized.

The internal master clock can be disabled in the PLL and Clock Control 0 register to reduce power dissipation when the AD1933 is idle. The clock should be stable before it is enabled. Unless a standalone mode is selected (see the Serial Control Port section), the clock is disabled by reset and must be enabled by writing to the SPI port for normal operation.

To maintain the highest performance possible, limit the clock jitter of the internal master clock signal to less than a 300 ps rms time interval error (TIE). Even at these levels, extra noise or tones can appear in the DAC outputs if the jitter spectrum contains large spectral peaks. If the internal PLL is not used, it is highly recommended that an independent crystal oscillator generate the master clock. In addition, it is especially important that the clock signal not be passed through an FPGA, CPLD, or other large digital chip (such as a DSP) before being applied to the AD1933. In most cases, this induces clock jitter due to the sharing of common power and ground connections with other unrelated digital output signals. When the PLL is used, jitter in the reference clock is attenuated above a certain frequency depending on the loop filter.

RESET AND POWER-DOWN

The function of the $\overline{\text{RST}}$ pin sets all the control registers to their default settings. To avoid pops, reset does not power down the analog outputs. After $\overline{\text{RST}}$ is deasserted, and the PLL acquires lock condition, an initialization routine runs inside the AD1933. This initialization lasts for approximately 256 master clock cycles.

The power-down bits in the PLL and Clock Control 0 and DAC Control 1 registers power down the respective sections. All other register settings are retained. To guarantee proper startup, the $\overline{\text{RST}}$ pin should be pulled low by an external resistor.

SERIAL CONTROL PORT

The AD1933 has an SPI control port that permits programming and reading back of the internal control registers for the ADCs, DACs, and clock system. A standalone mode is also available for operation without serial control; standalone is configured at reset by connecting CIN, CCLK, and CLATCH to ground. In standalone mode, all registers are set to default, except the internal MCLK enable, which is set to 1. The ADC ABCLK and ALRCLK clock ports are set to master/slave by the connecting the COUT pin to either DVDD or ground. Standalone mode only supports stereo mode with an I²S data format and 256 fs MCLK rate. Refer to Table 11 for details. If CIN, CCLK, and CLATCH are not grounded, the AD1933 SPI port is active. It is recommended to use a weak pull-up resistor on CLATCH in applications that have a microcontroller. This pull-up resistor ensures that the AD1933 recognizes the presence of a microcontroller.

The SPI control port of the AD1933 is a 4-wire serial control port. The format is similar to the Motorola SPI format except the input data-word is 24 bits wide. The serial bit clock and latch can be completely asynchronous to the sample rate of the DACs. Figure 9 shows the format of the SPI signal. The first byte is a global address with a read/write bit. For the AD1933, the address is 0x04, shifted left 1 bit due to the R/W bit. The second byte is the AD1933 register address and the third byte is the data.

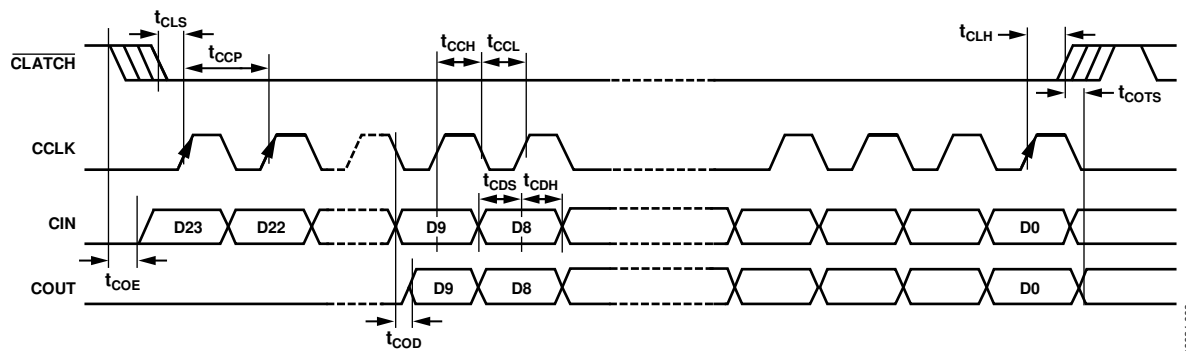

Figure 9. Format of SPI Signal

06624-009

POWER SUPPLY AND VOLTAGE REFERENCE

The AD1933 is designed for 3.3 V supplies. Separate power supply pins are provided for the analog and digital sections. These pins should be bypassed with 100 nF ceramic chip capacitors, as close to the pins as possible, to minimize noise pickup. A bulk aluminum electrolytic capacitor of at least 22 μF should also be provided on the same PCB as the DAC. For critical applications, improved performance is obtained with separate supplies for the analog and digital sections. If this is not possible, it is recommended that the analog and digital supplies be isolated by means of a ferrite bead in series with each supply. It is important that the analog supply be as clean as possible.

The AD1933 includes a 3.3 V regulator driver that only requires an external pass transistor and bypass capacitors to make a 5 V to 3.3 V regulator. If the regulator driver is not used, connect VSUPPLY, VDRIVE, and VSENSE to DGND.

All digital inputs are compatible with TTL and CMOS levels. All outputs are driven from the 3.3 V DVDD supply and are compatible with TTL and 3.3 V CMOS levels.

The DAC internal voltage reference (VREF) is brought out on FILTR and should be bypassed as close as possible to the chip, with a parallel combination of 10 μF and 100 nF. Any external current drawn should be limited to less than 50 μA .

The internal reference can be disabled in the PLL and Clock Control 1 register and FILTR can be driven from an external source. This can be used to scale the DAC output to the clipping level of a power amplifier based on its power supply voltage, DAC output gain is proportional to the FILTR voltage.

The CM pin is the internal common-mode reference. It should be bypassed as close as possible to the chip, with a parallel combination of 47 μF and 100 nF. This voltage can be used to bias external op amps to the common-mode voltage of the input and output signal pins. The output current should be limited to less than 0.5 mA source and 2 mA sink.

SERIAL DATA PORTS—DATA FORMAT

The eight DAC channels use a common serial bit clock (DBCLK) and a common left-right framing clock (DLRCLK) in the serial data port. The clock signals are all synchronous with the sample rate. The normal stereo serial modes are shown in Figure 15.

The DAC serial data modes default to I²S. The ports can also be programmed for left-justified, right-justified, and TDM modes. The word width is 24 bits by default and can be programmed for 16 or 20 bits. The DAC serial formats are programmable according to the DAC Control 0 register. The polarity of the DBCLK and DLRCLK is programmable according to the DAC Control 1 register. The auxiliary TDM port is also provided for

applications requiring more than eight DAC channels. In this mode, the AUXTDMLRCLK and AUXTDMBCLK pins are configured as TDM port clocks. In regular TDM mode, the DLRCLK and DBCLK pins are used as the TDM port clocks. The auxiliary TDM serial port format and its serial clock polarity are programmable according to the Auxiliary TDM Port Control 0 register and the Auxiliary TDM Port Control 1 register. Both DAC and auxiliary TDM serial ports are programmable to become the bus masters according to the DAC Control 1 register and auxiliary TDM Control 1 register. By default, both auxiliary TDM and DAC serial ports are in slave mode.

TIME-DIVISION MULTIPLEXED (TDM) MODES

The AD1933 serial ports have several different TDM serial data modes. The most commonly used configuration is shown in Figure 10. In Figure 10, the eight on-chip DAC data slots are packed into one TDM stream. In this mode, DBCLK is 256 f_s .

The I/O pins of the serial ports are defined according to the serial mode selected. For a detailed description of the function of each pin in TDM and auxiliary modes, see Table 11.

The AD1933 allows systems with more than eight DAC channels to be easily configured by the use of an auxiliary serial data port. The DAC TDM-AUX mode is shown in Figure 11. In this mode, the AUX channels are the last four slots of the 16-channel TDM data stream. These slots are extracted and output to the AUX serial port. One major difference between the TDM mode and an auxiliary TDM mode is the assignment of the TDM port pins, as shown in Table 11. In auxiliary TDM mode, DBCLK and DLRCLK are assigned as the auxiliary port clocks, and AUXTDMBCLK and AUXTDMLRCLK are assigned as the TDM port clocks. In regular TDM or 16-channel, daisy-chain TDM mode, the DLRCLK and DBCLK pins are set as the TDM port clocks.

It should be noted that due to the high AUXTDMBCLK frequency, 16-channel auxiliary TDM mode is available only in the 48 kHz/44.1 kHz/32 kHz sample rate.

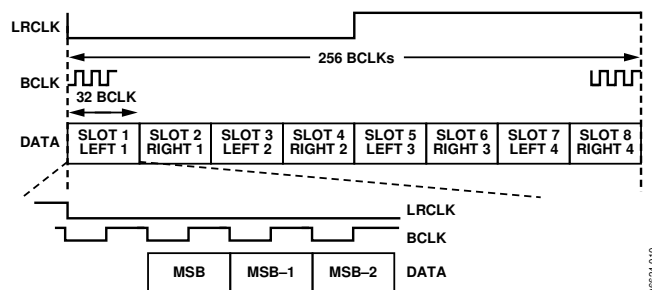

Figure 10. DAC TDM (8-Channel I²S Mode)

06624-010

Table 11. Pin Function Changes in TDM-AUX Mode

Pin Name	Stereo Modes	TDM Modes	AUX Modes
AUXDATA1	Not Used (Float)	Not Used (Float)	AUX Data Out 1 (to External DAC 1)
DSDATA1	DAC 1 Data In	DAC TDM Data In	TDM Data In
DSDATA2	DAC 2 Data In	DAC TDM Data Out	Not Used (Ground)
DSDATA3	DAC 3 Data In	DAC TDM Data In 2 (Dual-Line Mode)	Not Used (Ground)
DSDATA4	DAC 4 Data In	DAC TDM Data Out 2 (Dual-Line Mode)	AUX Data Out 2 (to External DAC 2)
AUXTDMRCLK	Not Used (Ground)	Not Used (Ground)	TDM Frame Sync In/TDM Frame Sync Out
AUXTDMBCLK	Not Used (Ground)	Not Used (Ground)	TDM BCLK In/TDM BCLK Out
DLRCLK	DAC LRCLK In/DAC LRCLK Out	DAC TDM Frame Sync In/DAC TDM Frame Sync Out	AUX LRCLK In/AUX LRCLK Out
DBCLK	DAC BCLK In/DAC BCLK Out	DAC TDM BCLK In/DAC TDM BCLK Out	AUX BCLK In/AUX BCLK Out

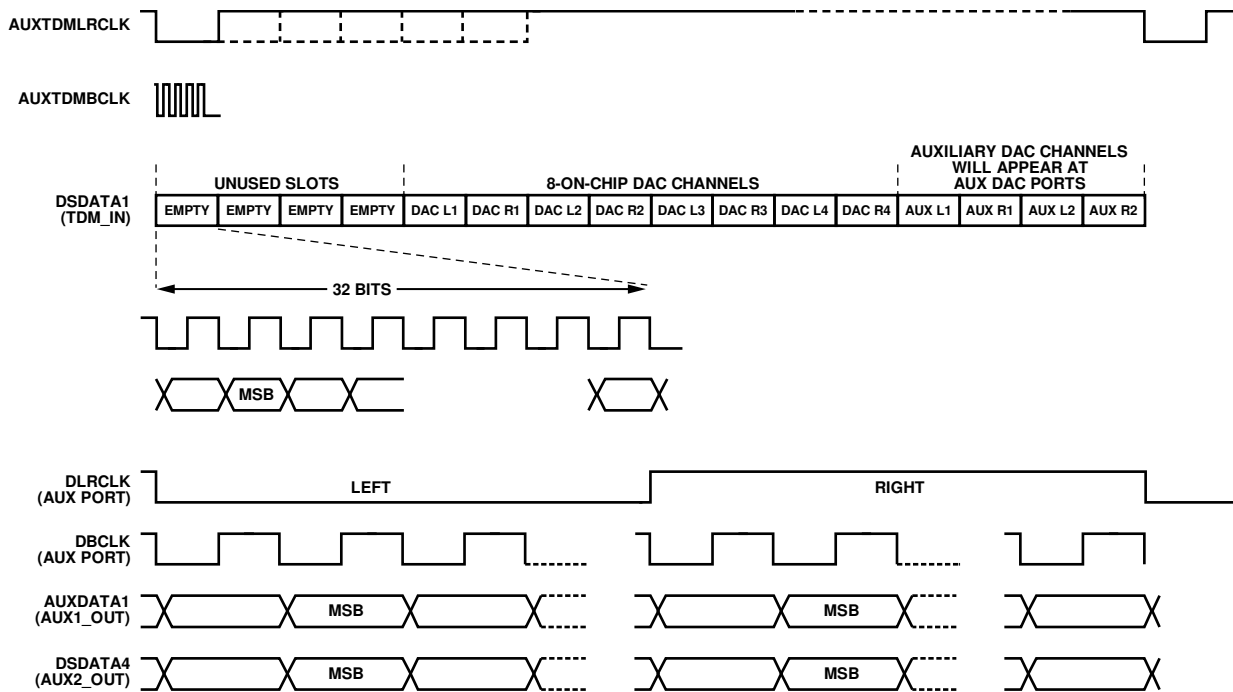

Figure 11. 16-Channel DAC TDM-AUX Mode

06824-011

DAISY-CHAIN MODE

The AD1933 also allows a daisy-chain configuration to expand the system 16 DACs (see Figure 12). In this mode, the DBCLK frequency is 512 fs. The first eight slots of the DAC TDM data stream belong to the first AD1933 in the chain and the last eight slots belong to the second AD1933. The second AD1933 is the device attached to the DSP TDM port.

To accommodate 16 channels at a 96 kHz sample rate, the AD1933 can be configured into a dual-line, DAC TDM mode, as shown in Figure 13. This mode allows a slower DBCLK than normally required by the one-line TDM mode.

Again, the first four channels of each TDM input belong to the first AD1933 in the chain and the last four channels belong to the second AD1933.

The dual-line, DAC TDM mode can also be used to send data at a 192 kHz sample rate into the AD1933, as shown in Figure 14. The I/O pins of the serial ports are defined according to the serial mode selected. See Table 12 for a detailed description of the function of each pin. See Figure 18 for a typical AD1933 configuration with two external stereo DACs. Figure 15 and Figure 16 show the serial mode formats. For maximum flexibility, the polarity of LRCLK and BCLK are programmable. In these figures, all of the clocks are shown with their normal polarity. The default mode is I²S.

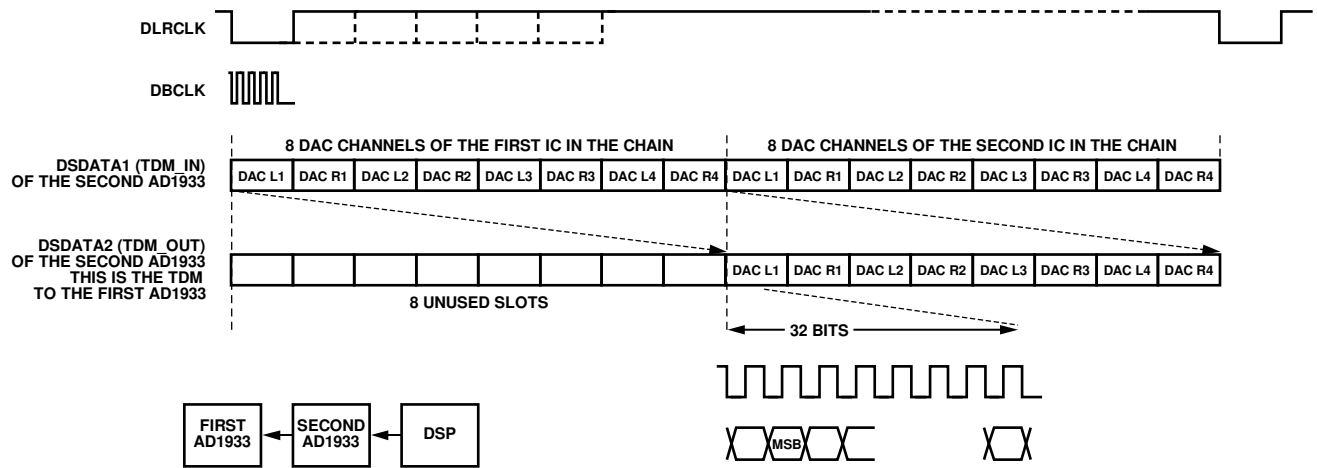

Figure 12. Single-Line DAC TDM Daisy-Chain Mode (Applicable to 48 kHz Sample Rate, 16-Channel, Two AD1933 Daisy Chain)

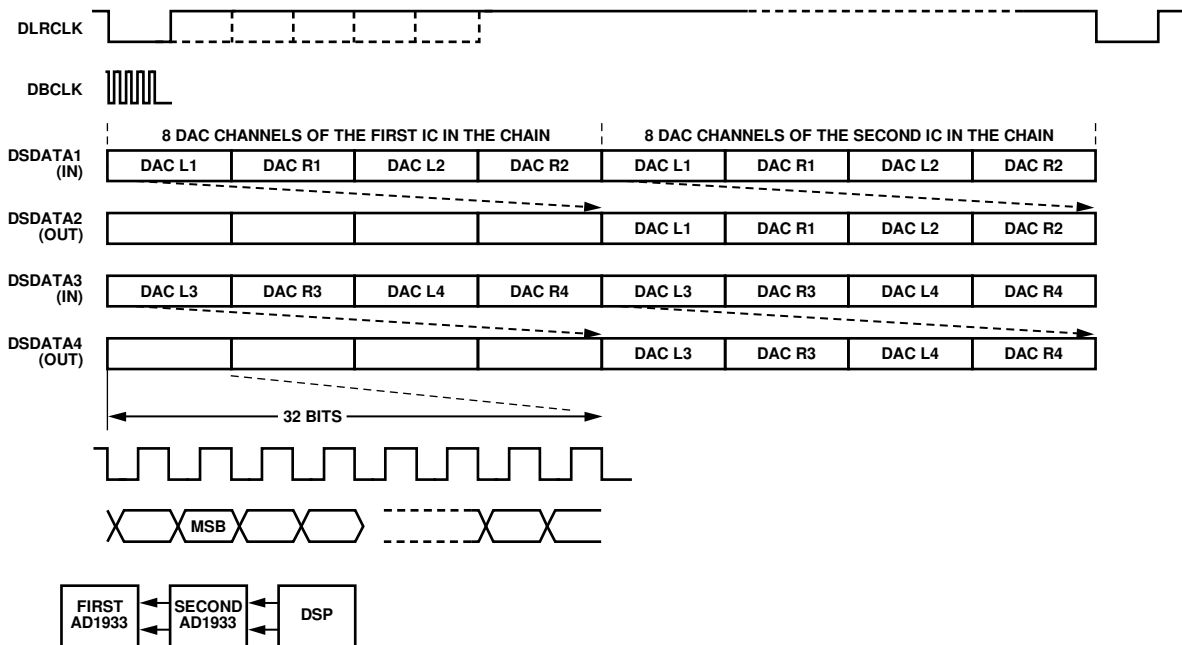

Figure 13. Dual-Line, DAC TDM Mode (Applicable to 96 kHz Sample Rate, 16-Channel, Two AD1933 Daisy Chain; DSDATA3 and DSDATA4 Are the Daisy Chain)

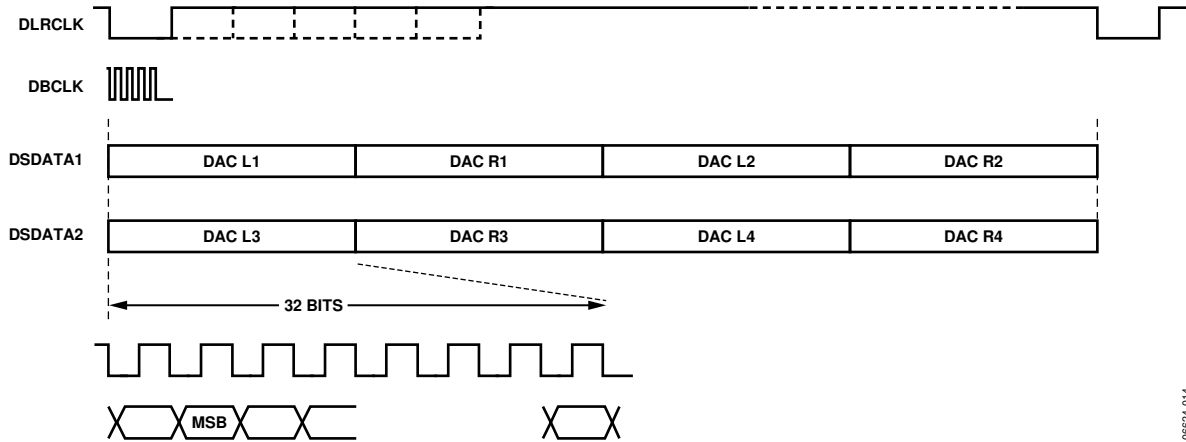
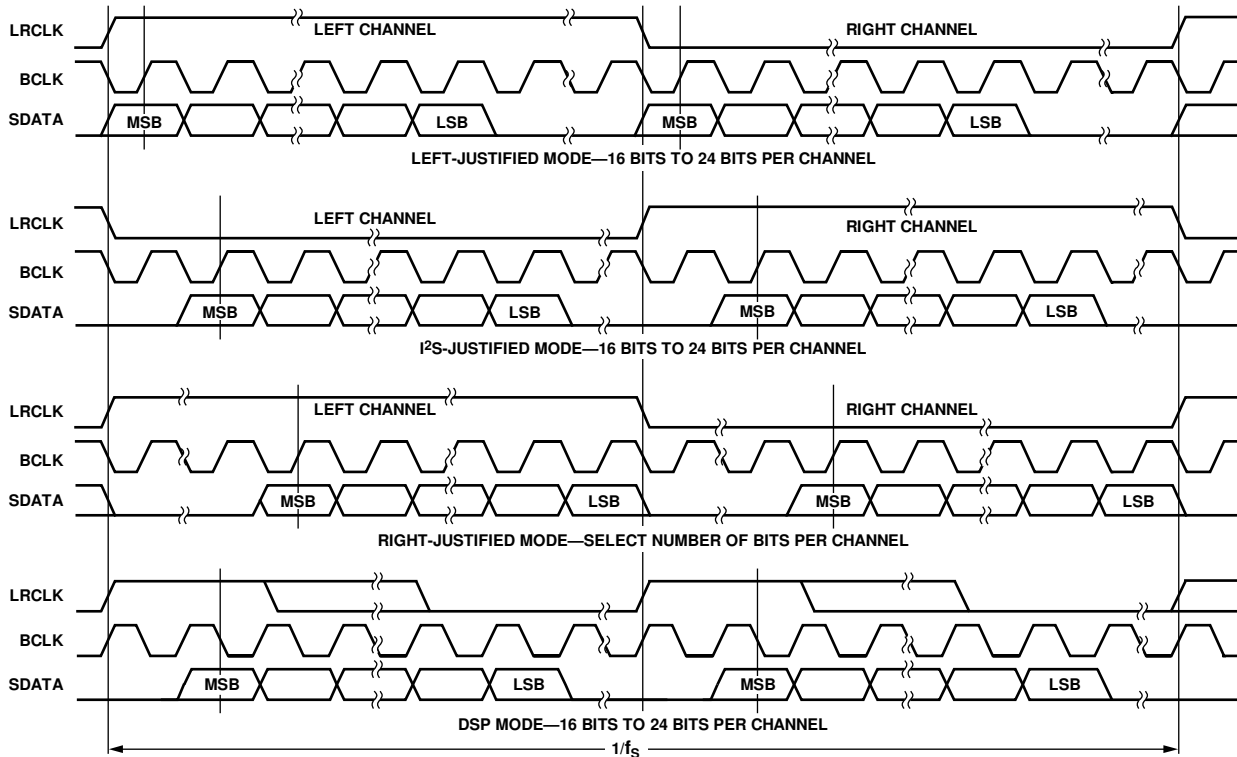

Figure 14. Dual-Line, DAC TDM Mode (Applicable to 192 kHz Sample Rate, 8-Channel Mode)

06624-014



NOTES

1. DSP MODE DOES NOT IDENTIFY CHANNEL.
2. LRCLK NORMALLY OPERATES AT f_s EXCEPT FOR DSP MODE, WHICH IS $2 \times f_s$.
3. BCLK FREQUENCY IS NORMALLY $64 \times$ LRCLK BUT MAY BE OPERATED IN BURST MODE.

Figure 15. Stereo Serial Modes

06624-015

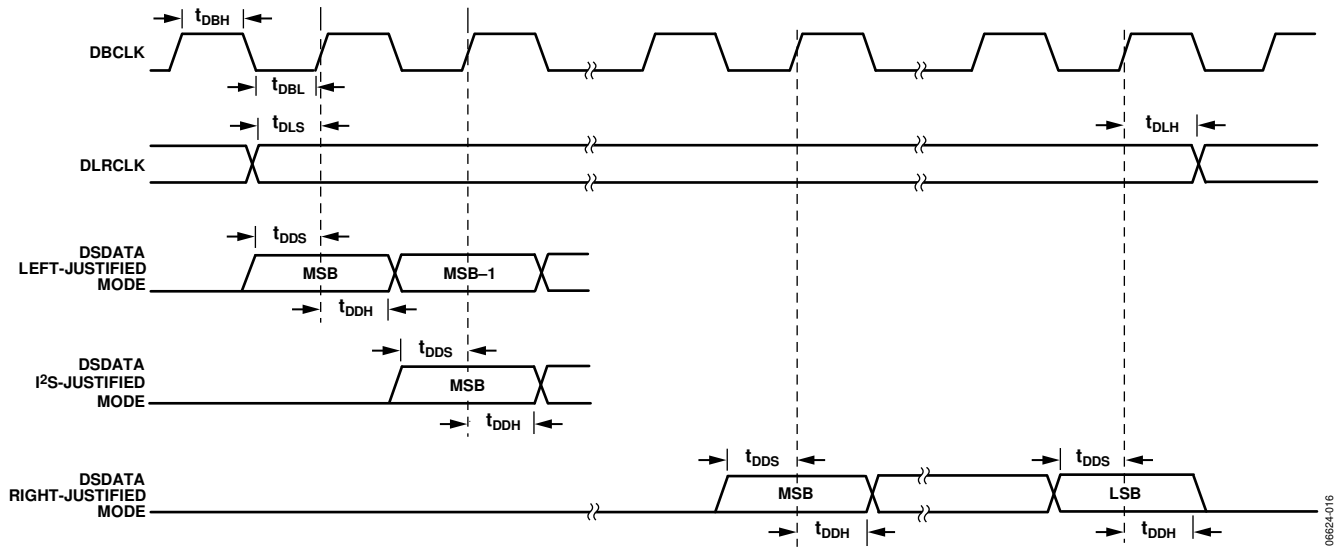

Figure 16. DAC Serial Timing

06624-016

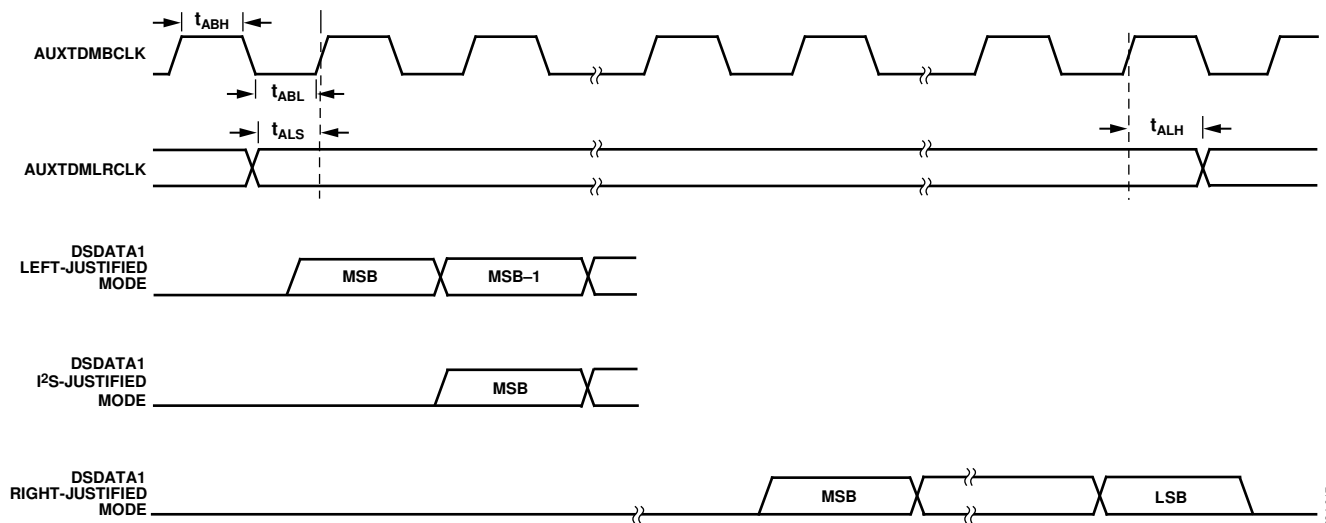

Figure 17. AUXTDM Serial Timing

06624-017

Table 12. Pin Function Changes in TDM-AUX Mode (Replication of Table 11)

Pin Name	Stereo Modes	TDM Modes	AUX Modes
AUXDATA1	Not Used (Float)	Not Used (Float)	AUX Data Out 1 (to External DAC 1)
DSDATA1	DAC 1 Data In	DAC TDM Data In	TDM Data In
DSDATA2	DAC 2 Data In	DAC TDM Data Out	Not Used (Ground)
DSDATA3	DAC 3 Data In	DAC TDM Data In 2 (Dual-Line Mode)	Not Used (Ground)
DSDATA4	DAC 4 Data In	DAC TDM Data Out 2 (Dual-Line Mode)	AUX Data Out 2 (to External DAC 2)
AUXTDMLRCLK	Not Used (Ground)	Not Used (Ground)	TDM Frame Sync In/TDM Frame Sync Out
AUXTDMBCLK	Not Used (Ground)	Not Used (Ground)	TDM BCLK In/TDM BCLK Out
DLRCLK	DAC LRCLK In/DAC LRCLK Out	DAC TDM Frame Sync In/DAC TDM Frame Sync Out	AUX LRCLK In/AUX LRCLK Out
DBCLK	DAC BCLK In/DAC BCLK Out	DAC TDM BCLK In/DAC TDM BCLK Out	AUX BCLK In/AUX BCLK Out

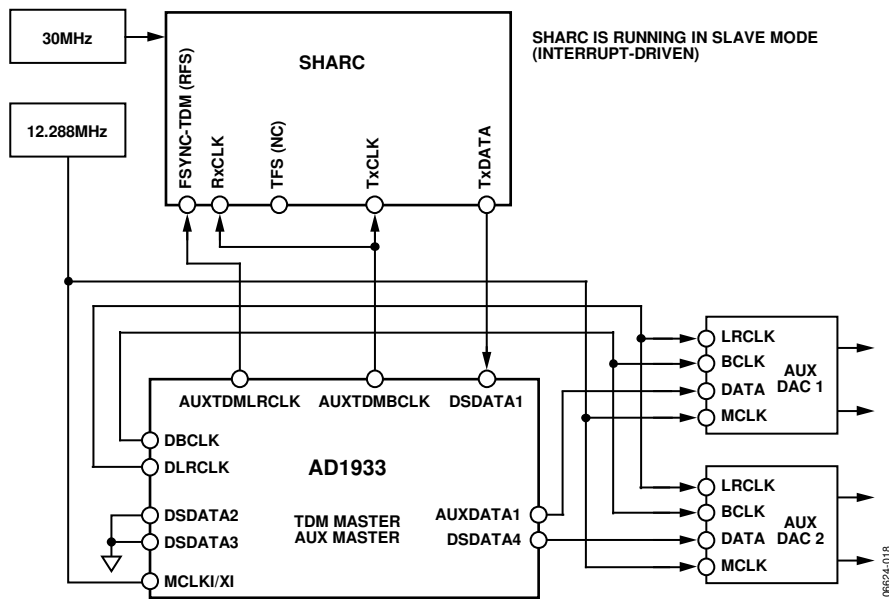

Figure 18. Example of AUX Mode Connection to SHARC® (AD1933 as TDM Master/AUX Master Shown)

CONTROL REGISTERS

DEFINITIONS

The global address for the AD1933 is 0x04, shifted left 1 bit due to the $\overline{R/W}$ bit. All registers are reset to 0, except for the DAC volume registers that are set to full volume.

Note that the first setting in each control register parameter is the default setting.

Table 13. Register Format

	Global Address	R/W	Register Address	Data
Bit	23:17	16	15:8	7:0

Table 14. Register Addresses and Functions

Address	Function
0	PLL and Clock Control 0
1	PLL and Clock Control 1
2	DAC Control 0
3	DAC Control 1
4	DAC Control 2
5	DAC individual channel mutes
6	DAC L1 volume control
7	DAC R1 volume control
8	DAC L2 volume control
9	DAC R2 volume control
10	DAC L3 volume control
11	DAC R3 volume control
12	DAC L4 volume control
13	DAC R4 volume control
14	Reserved
15	Auxiliary TDM Port Control 0
16	Auxiliary TDM Port Control 1

PLL AND CLOCK CONTROL REGISTERS

Table 15. PLL and Clock Control 0

Bit	Value	Function	Description
0	0	Normal operation	PLL power-down
	1	Power-down	
2:1	00	Input 256 (×44.1 kHz or 48 kHz)	MCLKI/XI pin functionality (PLL active), master clock rate setting
	01	Input 384 (×44.1 kHz or 48 kHz)	
	10	Input 512 (×44.1 kHz or 48 kHz)	
	11	Input 768 (×44.1 kHz or 48 kHz)	
4:3	00	XTAL oscillator enabled	MCLKO/XO pin, master clock rate setting
	01	256 × f _s VCO output	
	10	512 × f _s VCO output	
	11	Off	
6:5	00	MCLKI/XI	PLL input
	01	DLRCLK	
	10	AUXTDMLRCLK	
	11	Reserved	
7	0	Disable: DAC idle	Internal master clock enable
	1	Enable: DAC active	

Table 16. PLL and Clock Control 1

Bit	Value	Function	Description
0	0	PLL clock	DAC clock source select
	1	MCLK	
1	0	PLL clock	Clock source select
	1	MCLK	
2	0	Enabled	On-chip voltage reference
	1	Disabled	
3	0	Not locked	PLL lock indicator (read-only)
	1	Locked	
7:4	0000	Reserved	

DAC CONTROL REGISTERS

Table 17. DAC Control 0

Bit	Value	Function	Description
0	0	Normal	Power-down
	1	Power-down	
2:1	00	32 kHz/44.1 kHz/48 kHz	Sample rate
	01	64 kHz/88.2 kHz/96 kHz	
	10	128 kHz/176.4 kHz/192 kHz	
	11	Reserved	
5:3	000	1	SDATA delay (BCLK periods)
	001	0	
	010	8	
	011	12	
	100	16	
	101	Reserved	
	110	Reserved	
	111	Reserved	
7:6	00	Stereo (normal)	Serial format
	01	TDM (daisy chain)	
	10	DAC aux mode (DAC-, TDM-coupled)	
	11	Dual-line TDM	

Table 18. DAC Control 1

Bit	Value	Function	Description
0	0	Latch in midcycle (normal)	BCLK active edge (TDM in)
	1	Latch in at end of cycle (pipeline)	
2:1	00	64 (2 channels)	BCLKs per frame
	01	128 (4 channels)	
	10	256 (8 channels)	
	11	512 (16 channels)	
3	0	Left low	LRCLK polarity
	1	Left high	
4	0	Slave	LRCLK master/slave
	1	Master	
5	0	Slave	BCLK master/slave
	1	Master	
6	0	DBCLK pin	BCLK source
	1	Internally generated	
7	0	Normal	BCLK polarity
	1	Inverted	

Table 19. DAC Control 2

Bit	Value	Function	Description
0	0	Unmute	Master mute
	1	Mute	
2:1	00	Flat	De-emphasis (32 kHz/44.1 kHz/48 kHz mode only)
	01	48 kHz curve	
	10	44.1 kHz curve	
	11	32 kHz curve	
4:3	00	24	Word width
	01	20	
	10	Reserved	
	11	16	
5	0	Noninverted	DAC output polarity
	1	Inverted	
7:6	00	Reserved	

Table 20. DAC Individual Channel Mutes

Bit	Value	Function	Description
0	0	Unmute	DAC 1 left mute
	1	Mute	
1	0	Unmute	DAC 1 right mute
	1	Mute	
2	0	Unmute	DAC 2 left mute
	1	Mute	
3	0	Unmute	DAC 2 right mute
	1	Mute	
4	0	Unmute	DAC 3 left mute
	1	Mute	
5	0	Unmute	DAC 3 right mute
	1	Mute	
6	0	Unmute	DAC 4 left mute
	1	Mute	
7	0	Unmute	DAC 4 right mute
	1	Mute	

Table 21. DAC Volume Controls

Bit	Value	Function	Description
7:0	0	No attenuation	DAC volume control
	1 to 254	-3/8 dB per step	
	255	Full attenuation	

AUXILIARY TDM PORT CONTROL REGISTERS

Table 22. Auxiliary TDM Control 0

Bit	Value	Function	Description
1:0	00	24	Word width
	01	20	
	10	Reserved	
	11	16	
4:2	000	1	SDATA delay (BCLK periods)
	001	0	
	010	8	
	011	12	
	100	16	
	101	Reserved	
	110	Reserved	
	111	Reserved	
6:5	00	Reserved	Serial format
	01	Reserved	
	10	DAC aux mode	
	11	Reserved	
7	0	Latch in midcycle (normal)	BCLK active edge (TDM in)
	1	Latch in at end of cycle (pipeline)	

Table 23. Auxiliary TDM Control 1

Bit	Value	Function	Description
0	0	50/50 (allows 32, 24, 20, or 16 bit clocks (BCLKs) per channel)	LRCLK format
	1	Pulse (32 BCLKs per channel)	
1	0	Drive out on falling edge (DEF)	BCLK polarity
	1	Drive out on rising edge	
2	0	Left low	LRCLK polarity
	1	Left high	
3	0	Slave	LRCLK master/slave
	1	Master	
5:4	00	64	BCLKs per frame
	01	128	
	10	256	
	11	512	
6	0	Slave	BCLK master/slave
	1	Master	
7	0	AUXTDMBCLK pin	BCLK source
	1	Internally generated	

ADDITIONAL MODES

The AD1933 offers several additional modes for board level design enhancements. To reduce the EMI in board level design, serial data can be transmitted without an explicit BCLK. See Figure 19 for an example of a DAC TDM data transmission mode that does not require high speed DBCLK. This configuration is applicable when the AD1933 master clock is generated by the PLL with the DLRCLK as the PLL reference frequency.

To relax the requirement for the setup time of the AD1933 in cases of high speed TDM data transmission, the AD1933 can latch in the data using the falling edge of DBCLK. This effectively dedicates the entire BCLK period to the setup time. This mode is useful in cases where the source has a large delay time in the serial data driver. Figure 20 shows this pipeline mode of data transmission. Both the BCLK-less and pipeline modes are available.

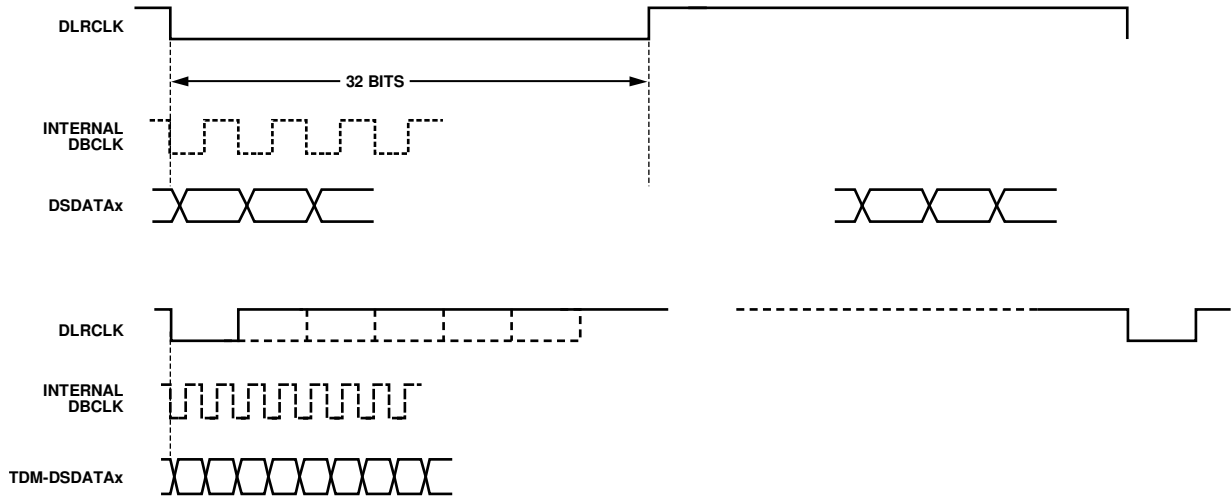

Figure 19. Serial DAC Data Transmission in TDM Format Without DBCLK (Applicable Only If PLL Locks to DLRCLK)

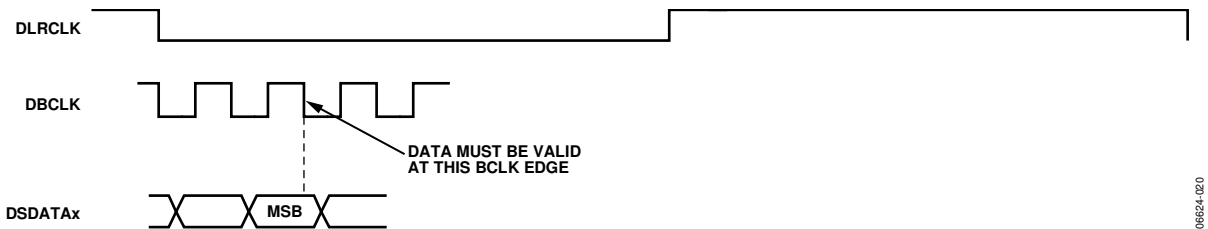
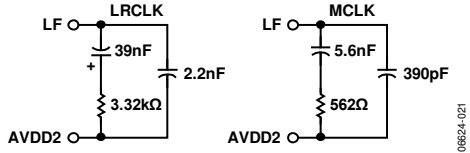

Figure 20. ^{PS} Pipeline Mode in DAC Serial Data Transmission (Applicable in Stereo and TDM Useful for High Frequency TDM Transmission)

APPLICATION CIRCUITS

Typical applications circuits are shown in Figure 21 through Figure 23. Figure 21 shows the recommended loop filters when using either the LR clock or the master clock as the PLL reference. Output filters for the DAC outputs are shown in Figure 22 and the regulator circuit is shown in Figure 23.



06624-021

Figure 21. Recommended Loop Filters for LRCLK or MCLK PLL Reference

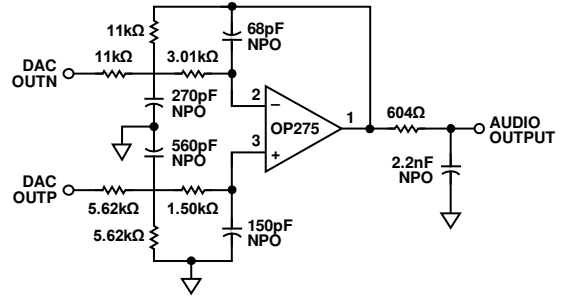

06624-022

Figure 22. Typical DAC Output Filter Circuit (Differential)

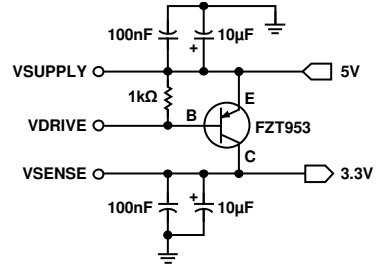

06624-023

Figure 23. Recommended 3.3 V Regulator Circuit

OUTLINE DIMENSIONS

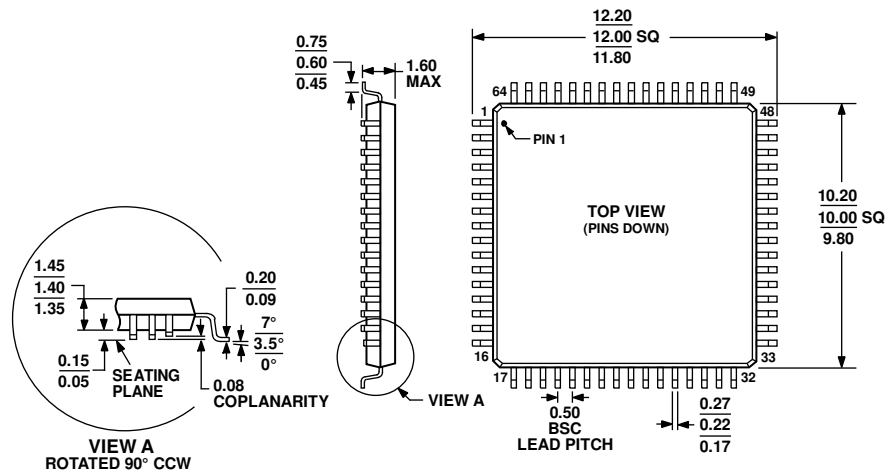

COMPLIANT TO JEDEC STANDARDS MS-026-BCD
 Figure 24. 64-Lead Low Profile Quad Flat Package [LQFP] (ST-64-2)
 Dimensions shown in millimeters

051706-A

ORDERING GUIDE

Model ^{1, 2, 3}	Temperature Range	Package Description	Package Option
AD1933YSTZ	-40°C to +105°C	64-Lead LQFP	ST-64-2
AD1933YSTZ-RL	-40°C to +105°C	64-Lead LQFP, 13" Tape and Reel	ST-64-2
AD1933WBSTZ	-40°C to +105°C	64-Lead LQFP	ST-64-2
AD1933WBSTZ-RL	-40°C to +105°C	64-Lead LQFP, 13" Tape and Reel	ST-64-2
EVAL-AD1939AZ		Evaluation Board	

¹ Z = RoHS Compliant Part.

² The EVAL-AD1939AZ should be used as the evaluation board for the AD1933. The AD1933 is a DAC-only equivalent to the AD1939.

³ W = Qualified for Automotive Applications.

AUTOMOTIVE PRODUCTS

The [AD1933W](#) models are available with controlled manufacturing to support the quality and reliability requirements of automotive applications. Note that these automotive models may have specifications that differ from the commercial models; therefore, designers should review the Specifications section of this data sheet carefully. Only the automotive grade products shown are available for use in automotive applications. Contact your local Analog Devices account representative for specific product ordering information and to obtain the specific Automotive Reliability reports for these models.

NOTES

NOTES

NOTES