

General Description

The AOZ8804ADI is a transient voltage suppressor array designed to protect high speed data lines such as HDMI, USB 3.0, MDDI, SATA, and Gigabit Ethernet from damaging ESD events.

This device incorporates eight surge rated, low capacitance steering diodes and a TVS in a single package. During transient conditions, the steering diodes direct the transient to either the positive side of the power supply line or to ground.

The AOZ8804ADI provides a typical line to line capacitance of 0.3pF and low insertion loss up to 6GHz providing greater signal integrity making it ideally suited for HDMI 1.3 or USB 3.0 applications, such as Digital TVs, DVD players, Computing, set-top boxes and MDDI applications in mobile computing devices.

The AOZ8804ADI comes in a RoHS compliant and Halogen Free 2.5mm x 1.0mm x 0.55mm DFN-10 package and is rated -40°C to +85°C junction temperature range.

Features

- ESD protection for high-speed data lines:
 - IEC 61000-4-2, level 4 (ESD) immunity test
 - Air discharge: ±15kV; contact discharge: ±15kV
 - IEC61000-4-4 (EFT) 40A (5/50nS)
 - IEC61000-4-5 (Lightning) 2.5A (8/20µS)
 - Human Body Model (HBM) ±24kV
- Array of surge rated diodes with internal TVS diode
- Small package saves board space
- Protects four I/O lines
- Low capacitance between I/O lines: 0.3pF
- Low clamping voltage
- Low operating voltage: 5.0V

Applications

- HDMI, USB 3.0, MDDI, SATA ports
- Monitors and flat panel displays
- Set-top box
- Video graphics cards
- Digital Video Interface (DVI)
- Notebook computers



Typical Applications

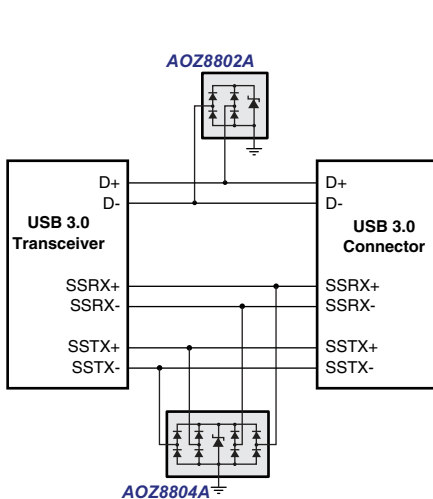

Figure 1. USB 3.0 Ports

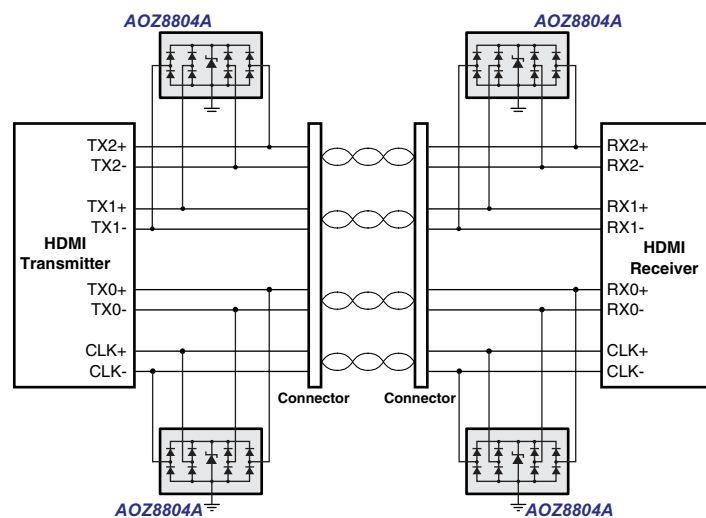

Figure 2. HDMI Ports

Ordering Information

Part Number	Ambient Temperature Range	Package	Environmental
AOZ8804ADI	-40°C to +85°C	DFN-10	RoHS Compliant Green Product



AOS Green Products use reduced levels of Halogens, and are also RoHS compliant.
Please visit www.aosmd.com/media/AOSGreenPolicy.pdf for additional information.

Pin Configuration

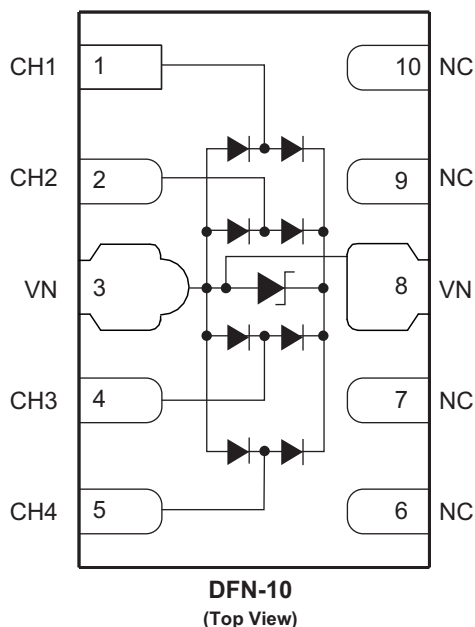

Absolute Maximum Ratings

Exceeding the Absolute Maximum ratings may damage the device.

Parameter	Rating
Storage Temperature (T_S)	-65°C to +150°C
ESD Rating per IEC61000-4-2, contact ⁽¹⁾	±15kV
ESD Rating per IEC61000-4-2, air ⁽¹⁾	±15kV
ESD Rating per Human Body Model ⁽²⁾	±24kV

Notes:

- IEC 61000-4-2 discharge with $C_{Discharge} = 150\text{pF}$, $R_{Discharge} = 330\Omega$.
- Human Body Discharge per MIL-STD-883, Method 3015 $C_{Discharge} = 100\text{pF}$, $R_{Discharge} = 1.5\text{k}\Omega$.

Maximum Operating Ratings

The device is not guaranteed to operate beyond the Maximum Operating ratings.

Parameter	Rating
Junction Temperature (T_J)	-40°C to +125°C

Electrical Characteristics

T_A = 25°C unless otherwise specified. Specifications in **BOLD** indicate a temperature range of -40°C to +85°C.

Symbol	Parameter	Conditions	Min.	Typ.	Max.	Units
V _{RWM}	Reverse Working Voltage	Between I/O and VN ⁽³⁾			5.0	V
V _{BR}	Reverse Breakdown Voltage	I _T = 1mA, between I/O and VN ⁽⁴⁾	6.0			V
I _R	Reverse Leakage Current	V _{RWM} = 5V, between I/O and VN			1	μA
V _F	Diode Forward Voltage	I _F = 15mA	0.70	0.85	1	V
V _{CL}	Channel Clamp Voltage Positive Transients Negative Transient	I _{PP} = 1A, t _p = 100ns, any I/O pin to Ground ⁽⁵⁾			12.0 -3.0	V V
	Channel Clamp Voltage Positive Transients Negative Transient	I _{PP} = 5A, t _p = 100ns, any I/O pin to Ground ⁽⁵⁾			14.0 -5.0	V V
	Channel Clamp Voltage Positive Transients Negative Transient	I _{PP} = 12A, t _p = 100ns, any I/O pin to Ground ⁽⁵⁾			16.5 -7.0	V V
	Channel Clamp Voltage Any I/O Pin to Ground	I _{PP} = 1A, t _p = 8/20μs			12.0	V
C _j	Channel Input Capacitance	V _R = 0V, f = 1MHz, between I/O pins		0.30	0.35	pF
		V _R = 0V, f = 1MHz, any I/O pin to Ground		0.60	0.75	pF

Notes:

- The working peak reverse voltage, V_{RWM}, should be equal to or greater than the DC or continuous peak operating voltage level.
- V_{BR} is measured at the pulse test current I_T.
- Measurements performed using a 100ns Transmission Line Pulse (TLP) system.

Typical Performance Characteristics

Forward Voltage vs. Forward Peak Pulse Current
(t_{period} = 100ns, t_r = 1ns)

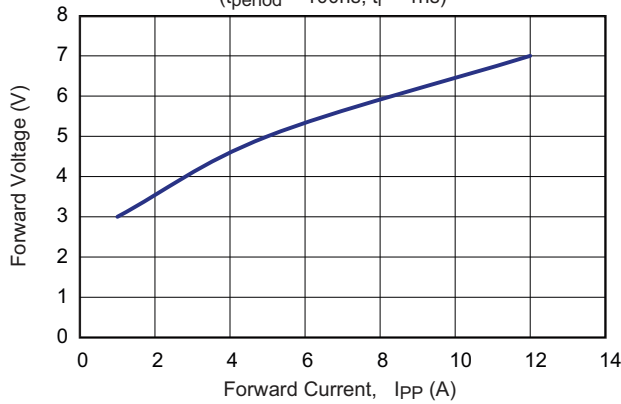

I/O – Gnd Insertion Loss (S21) vs. Frequency

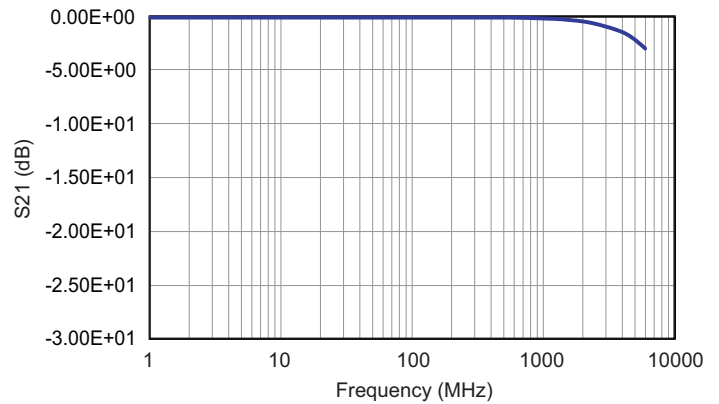

Clamping Voltage vs. Peak Pulse Current
(t_{period} = 100ns, t_r = 1ns)

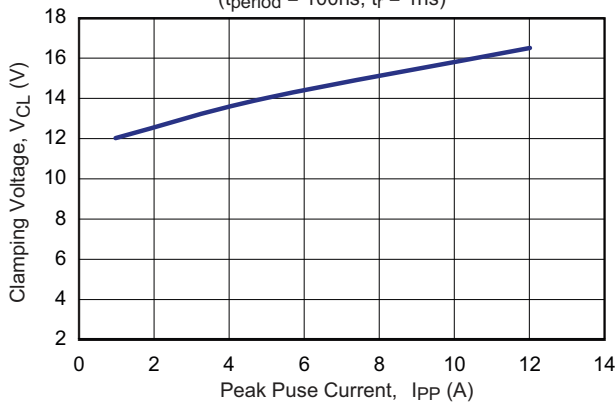

Analog Crosstalk (I/O–I/O) vs. Frequency

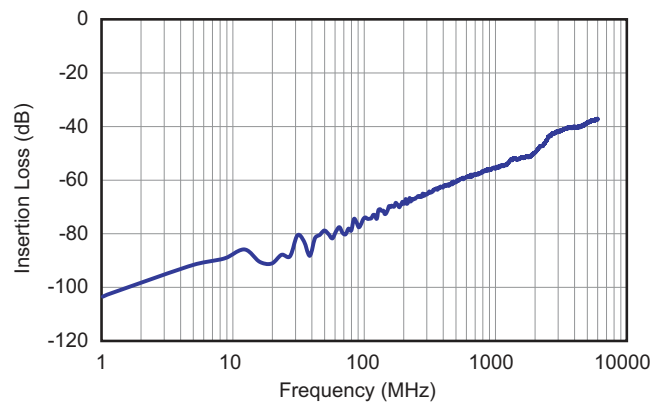

Capacitance vs. Frequency (IO to GND)

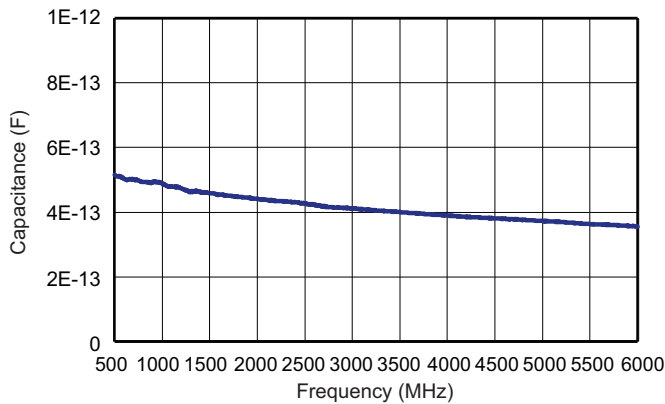

USB3.0 Eye Diagram with AOZ8804A (5Gbps)

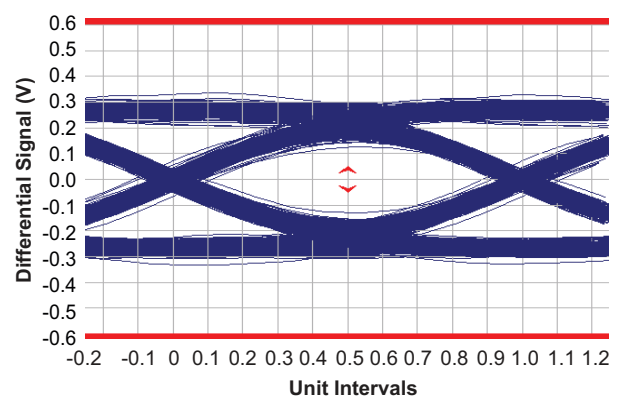

TDR for HDMI 1.3

The AOZ8804ADI TDR test results indicates the minimal effect the low capacitance has on the HDMI 1.3 TDR measurements. Figure 3 and Figure 4 below are the graphs from the TDR measurements. The two graphs show the before and after results of the TDR differential data line of the HDMI when the AOZ8804ADI was populated onto the PCB. The use of "Skinny Traces" can

further limit the TDR to within $100\Omega \pm 5\Omega$. Below are the TDR measurements with the use of skinny traces to compensate the added capacitor from the AOZ8804. Figure 3 shows the increase in impedance from the skinny traces between M1 and M2 cursors. With the increase in impedance the AOZ8804ADI added capacitor will now reduce the TDR within the $100\Omega \pm 5\Omega$.

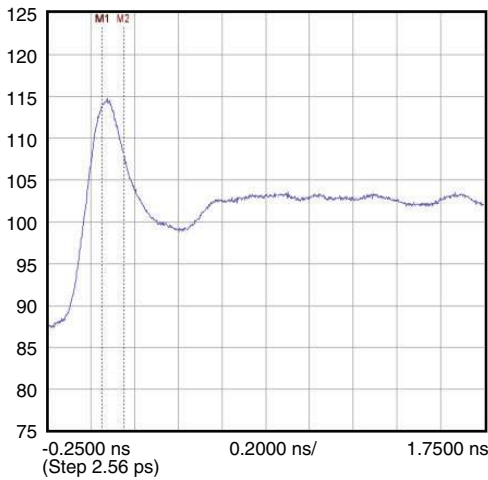

Figure 3. Compensated Stripe-Line

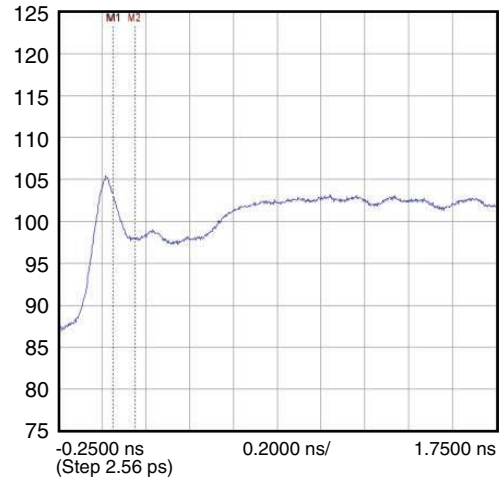

Figure 4. Compensated Stripe-Line with AOZ8804ADI Device on the Board

Figure 5 shows the graphical representation of the scope photo of the TDR and the PCB board. The cursor M1 represent the edge of the connector in which the

equipment was calibrated to. The cursor M2 represent the leveling off of the 100Ω when the signal passes through the AOZ8804ADI.

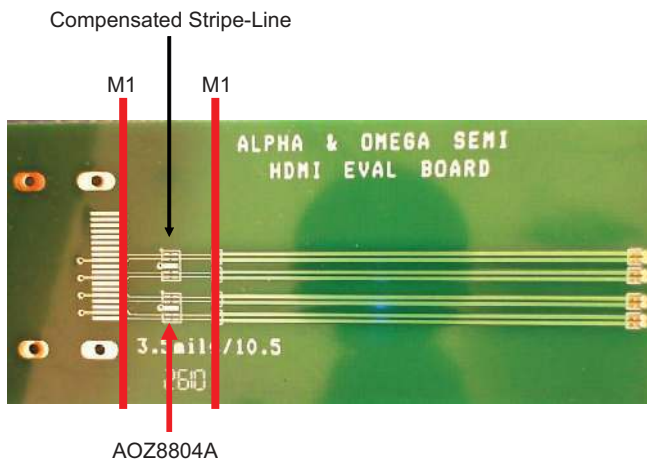

Figure 5. AOS HDMI Compensated Evaluation Board

Number of Layers	4
Copper Trace Thickness	1.4 mils
Dielectric Constant, ϵ_r	4.6
Overall Board Thickness	62 mils
Dielectric Thickness Between Top and Ground Layer	10 mils

High Speed PCB Layout Guidelines

Printed circuit board layout is the key to achieving the highest level of surge immunity on power and data lines. The location of the protection devices on the PCB is the simplest and most important design rule to follow. The AOZ8804ADI devices should be located as close as possible to the noise source. The placement of the AOZ8804ADI devices should be used on all data and power lines that enter or exit the PCB at the I/O connector. In most systems, surge pulses occur on data and power lines that enter the PCB through the I/O connector. Placing the AOZ8804ADI devices as close as possible to the noise source ensures that a surge voltage will be clamped before the pulse can be coupled into adjacent PCB traces. In addition, the PCB should use the shortest possible traces. A short trace length equates to low impedance, which ensures that the surge energy will be dissipated by the AOZ8804ADI device. Long signal traces will act as antennas to receive energy from fields that are produced by the ESD pulse. By keeping line lengths as short as possible, the efficiency of the line to act as an antenna for ESD related fields is reduced. Minimize interconnecting line lengths by placing devices with the most interconnect as close together as possible. The protection circuits should shunt the surge voltage to either the reference or chassis ground. Shunting the surge voltage directly to the IC's signal ground can cause ground bounce. The clamping performance of TVS diodes on a single ground PCB can be improved by

minimizing the impedance with relatively short and wide ground traces. The PCB layout and IC package parasitic inductances can cause significant overshoot to the TVS's clamping voltage. The inductance of the PCB can be reduced by using short trace lengths and multiple layers with separate ground and power planes. One effective method to minimize loop problems is to incorporate a ground plane in the PCB design.

The AOZ8804ADI ultra-low capacitance TVS is designed to protect four high speed data transmission lines from transient over-voltages by clamping them to a fixed reference. The low inductance and construction minimizes voltage overshoot during high current surges. When the voltage on the protected line exceeds the reference voltage the internal steering diodes are forward biased, conducting the transient current away from the sensitive circuitry. The AOZ8804ADI is designed for the ease of PCB layout by allowing the traces to run underneath the device. The pinout of the AOZ8804ADI is designed to simply drop onto the IO lines of a High Definition Multimedia Interface (HDMI) or USB 3.0 design without having to divert the signal lines that may add more parasitic inductance. Pins 1, 2, 4 and 5 are connected to the internal TVS devices and pins 6, 7, 9 and 10 are no connects. The no connects was done so the package can be securely soldered onto the PCB surface.

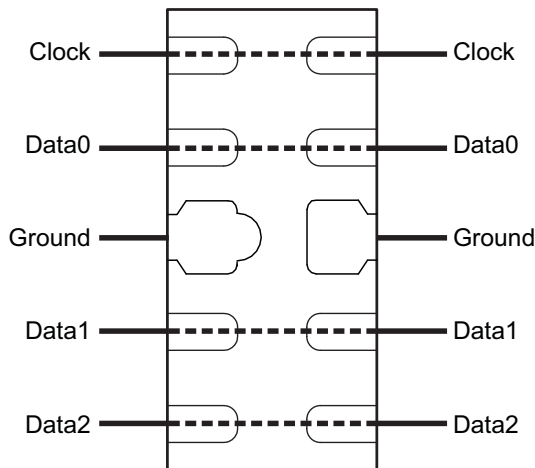

Figure 6. Flow Through Layout for HDMI

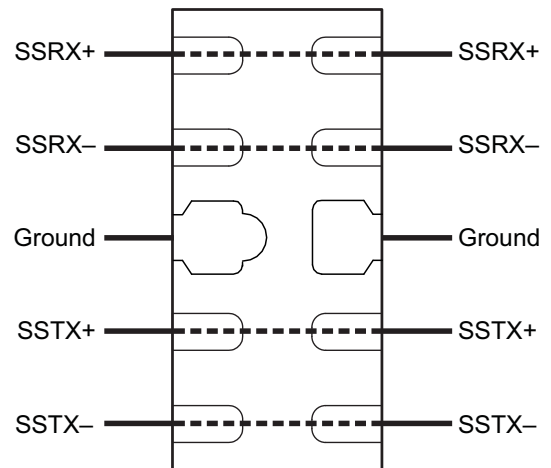

Figure 7. Flow Through Layout for USB 3.0

High Speed PCB Layout Guidelines (Continued)

Based on the AOZ8804ADI DFN-10 package design a very straight forward layout can be achieved. To give the TDR an extra level of margin the traces may be compensated to have a nominal impedance of 90Ω for USB or 100Ω for HDMI throughout the differential pair. To make the design perfect the added capacitance of the device will have to be compensated by the use of "Skinny Traces". The skinny traces are a narrow stripe line acting to lower the parasitic capacitance on the differential stripe

line. The differential impedance of the transmission line becomes well centered to 90Ω or to 100Ω . A layout EM field simulator is recommended before fabrication to insure a perfect stripe line. With careful layout and placement of the device, the AOZ8804ADI can protect the USB 3.0 and HDMI data line effectively and safely and meet the ESD immunity requirements of the IEC61000-4-2, level 4, $\pm 15\text{kV}$ air discharge, $\pm 8\text{kV}$ contact discharge.

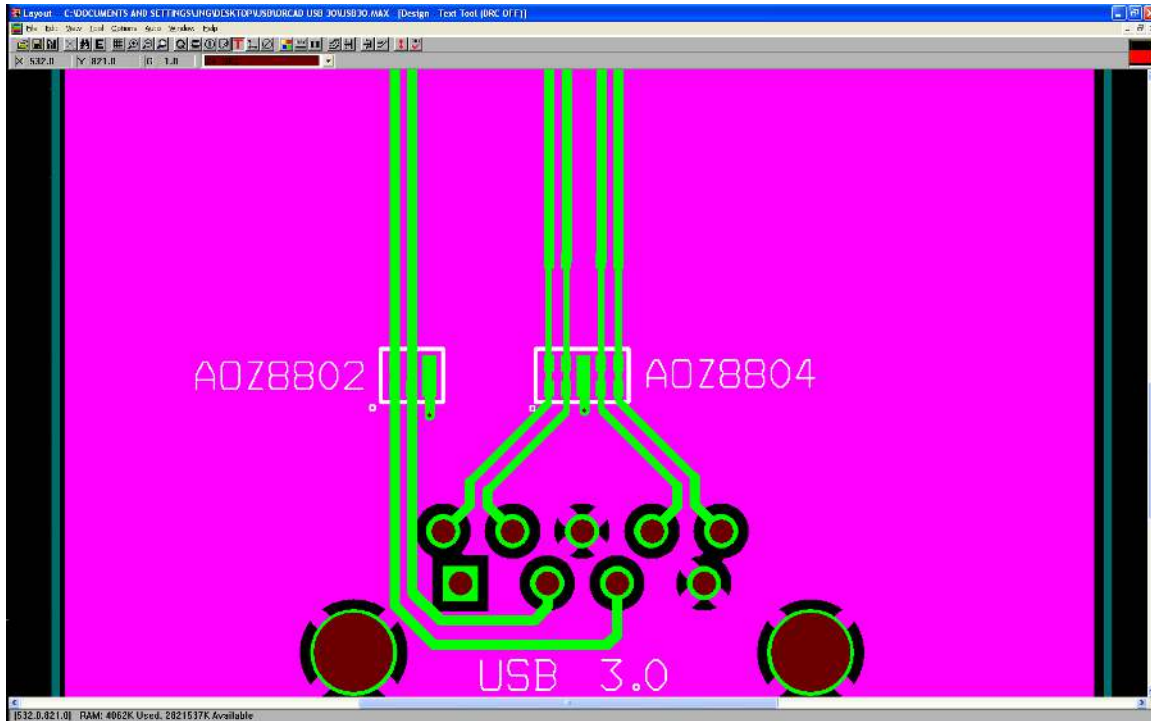

Figure 8. USB 3.0 PCB Layout with Compensated Traces

Number of Layers	4
Copper Trace Thickness	1.4 mils
Dielectric Constant, ϵ_r	4.6
Overall Board Thickness	62 mils
Dielectric Thickness Between Top and Ground Layer	10 mils

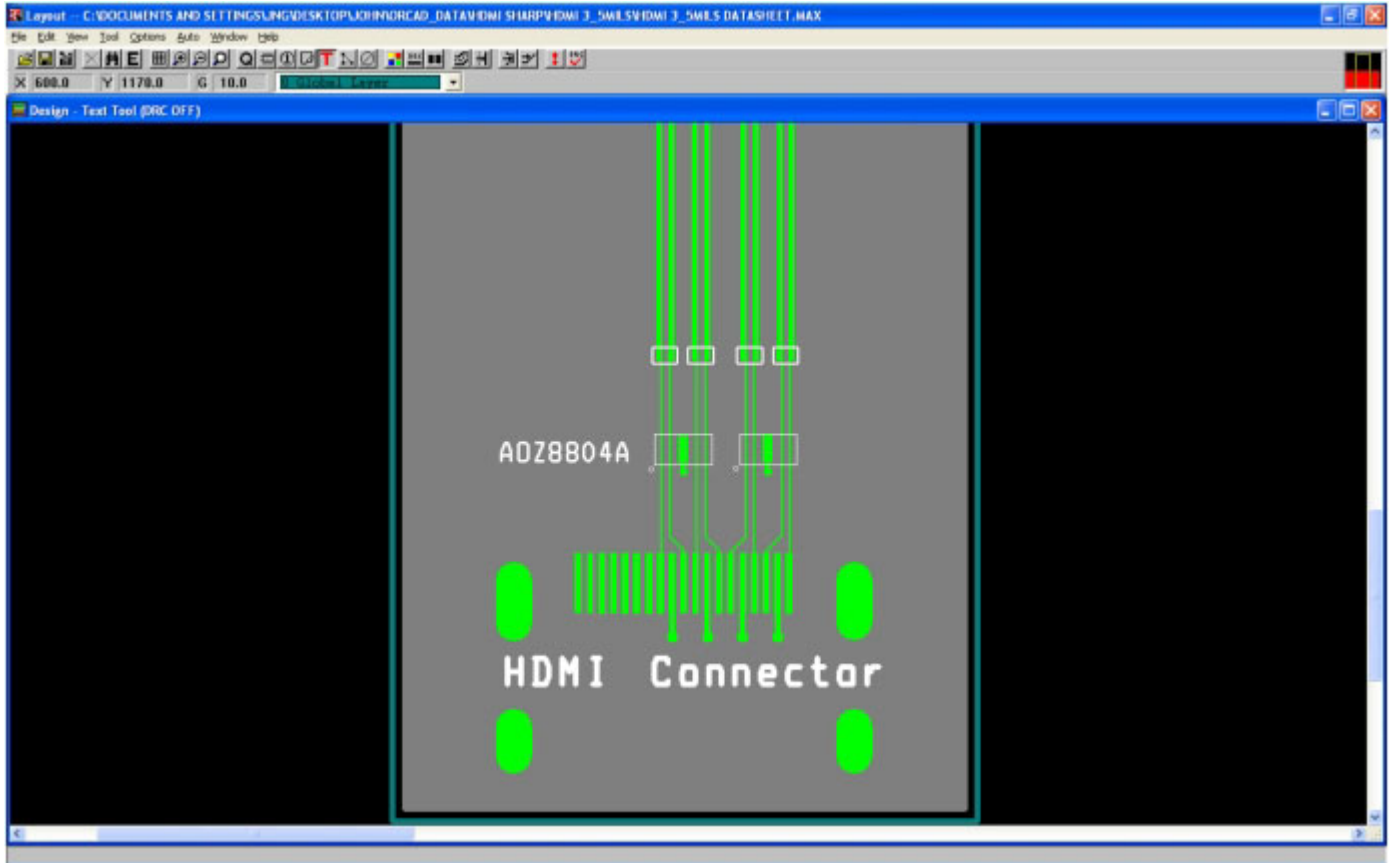

Figure 9. HDMI PCB Layout with Compensated Traces

Number of Layers	4
Copper Trace Thickness	1.4 mils
Dielectric Constant, ϵ_r	4.6
Overall Board Thickness	62 mils
Dielectric Thickness Between Top and Ground Layer	10 mils

LEGAL DISCLAIMER

Applications or uses as critical components in life support devices or systems are not authorized. AOS does not assume any liability arising out of such applications or uses of its products. AOS reserves the right to make changes to product specifications without notice. It is the responsibility of the customer to evaluate suitability of the product for their intended application. Customer shall comply with applicable legal requirements, including all applicable export control rules, regulations and limitations.

AOS' products are provided subject to AOS' terms and conditions of sale which are set forth at:

http://www.aosmd.com/terms_and_conditions_of_sale

LIFE SUPPORT POLICY

ALPHA AND OMEGA SEMICONDUCTOR PRODUCTS ARE NOT AUTHORIZED FOR USE AS CRITICAL COMPONENTS IN LIFE SUPPORT DEVICES OR SYSTEMS.
As used herein:

1. Life support devices or systems are devices or systems which, (a) are intended for surgical implant into the body or (b) support or sustain life, and (c) whose failure to perform when properly used in accordance with instructions for use provided in the labeling, can be reasonably expected to result in a significant injury of the user.
2. A critical component in any component of a life support, device, or system whose failure to perform can be reasonably expected to cause the failure of the life support device or system, or to affect its safety or effectiveness.