

THIS DRAWING IS UNPUBLISHED. RELEASED FOR PUBLICATION
 © COPYRIGHT - By - ALL RIGHTS RESERVED.

LOC	DIST	REVISIONS					
CM	00	P	LTR	DESCRIPTION	DATE	DWN	APVD
		G		REVISED PER ECR-13-008204	11DEC2013	KH	TM

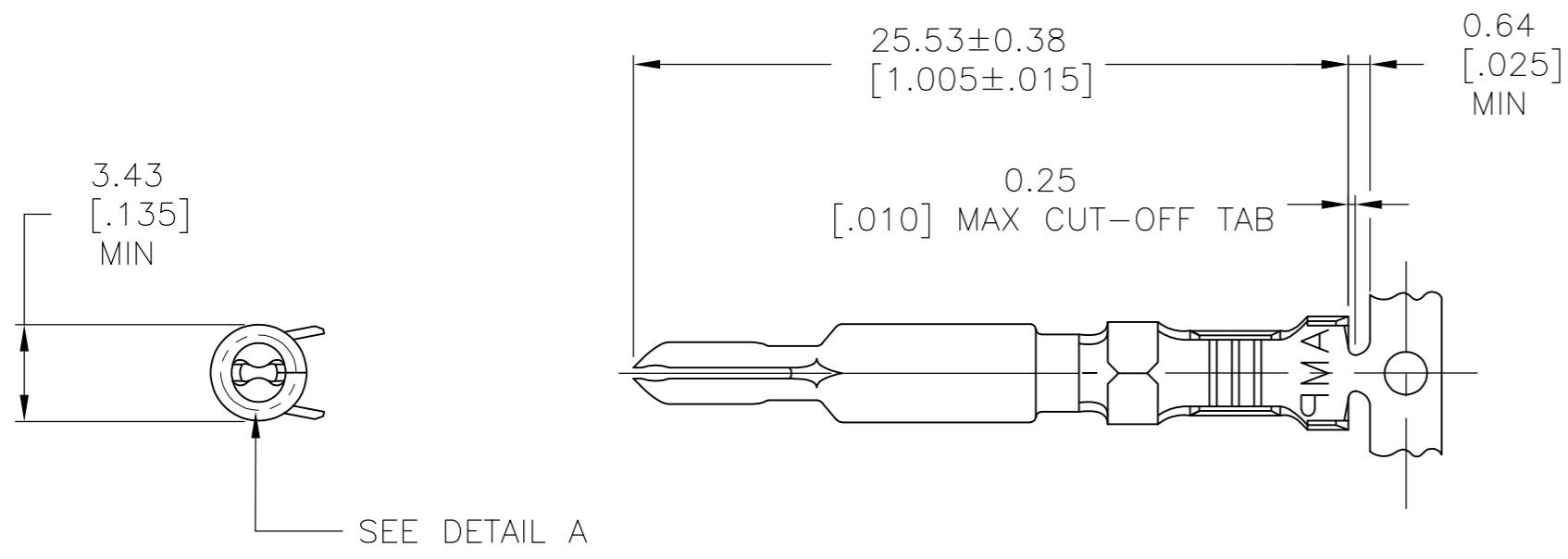

SEE DETAIL A

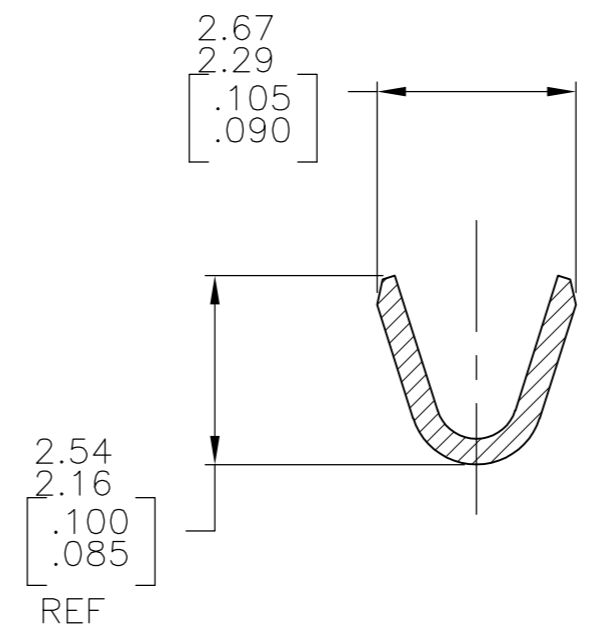
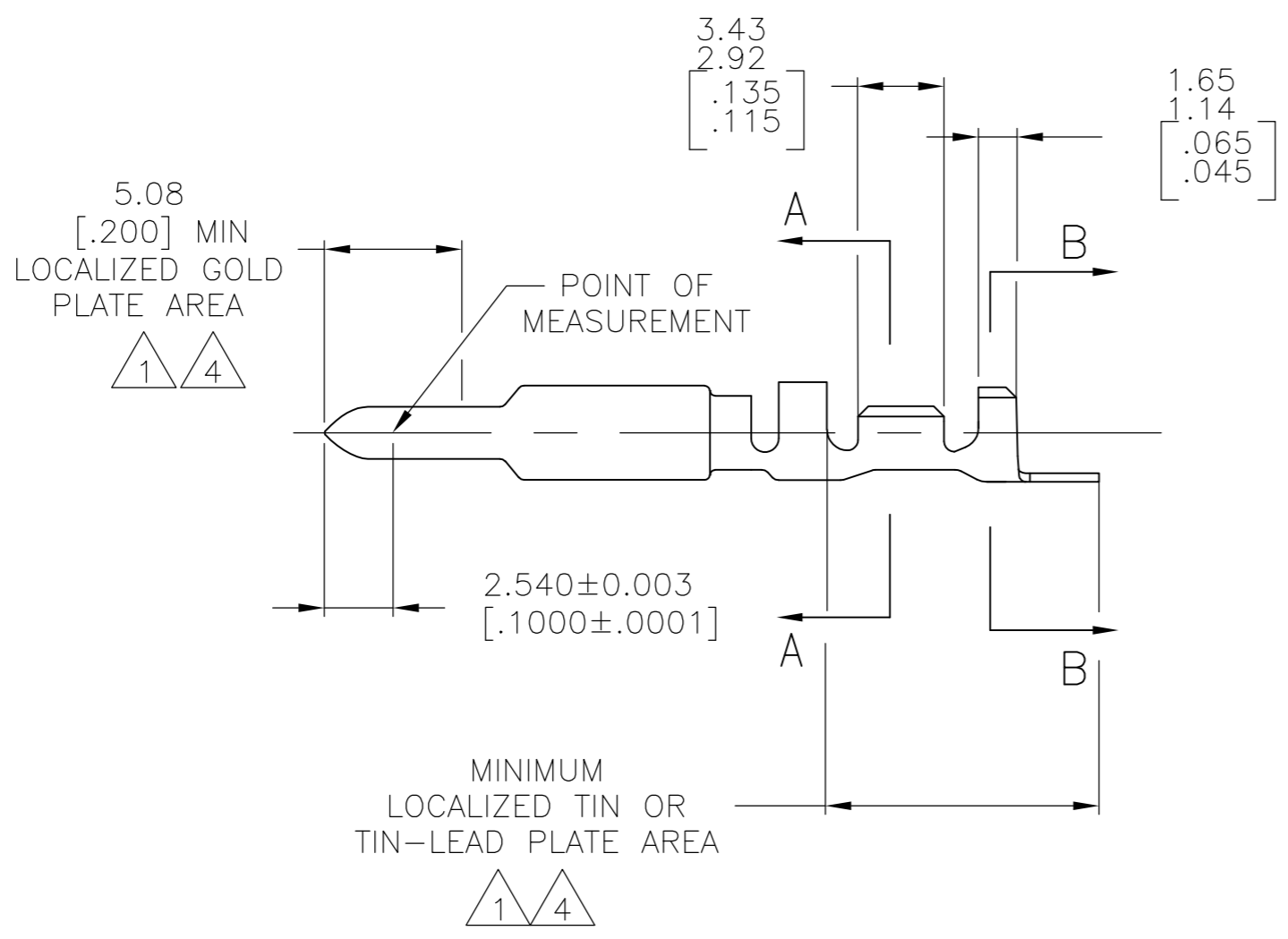

SECTION A-A
SCALE 10:1

- 1 0.00076[.000030] MIN GOLD AT POINT OF MEASUREMENT IN THE LOCALIZED GOLD PLATE AREA, 0.00127[.000050] MIN TIN-LEAD IN TIN-LEAD PLATE AREA, 0.00127[.000050] MIN NICKEL UNDERPLATE ON ENTIRE CONTACT.
- 2. WIRE RANGE: 0.2-1mm² [24-18 AWG]
INSULATION RANGE: 1.02-2.54[.040-.100] DIA.
- 3. DIMENSIONS IN BRACKETS ARE IN INCHES.
- 4 0.00076[.000030] MIN GOLD AT POINT OF MEASUREMENT IN THE LOCALIZED GOLD PLATE AREA, 0.00127[.000050] MIN TIN IN TIN PLATE AREA, 0.00127[.000050] MIN NICKEL UNDERPLATE ON ENTIRE CONTACT.
- 5 SUPERSEDED BY 1-770009-0

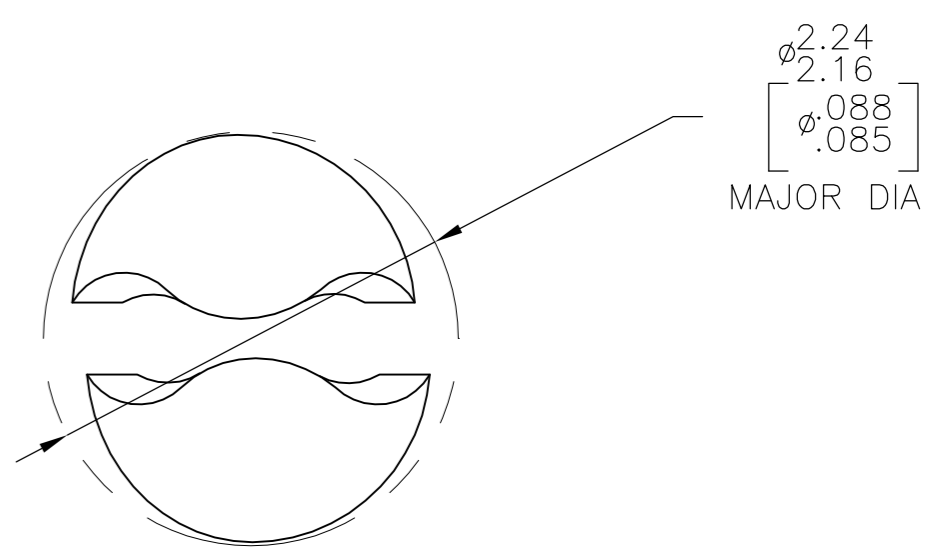

DETAIL A
SCALE 20:1

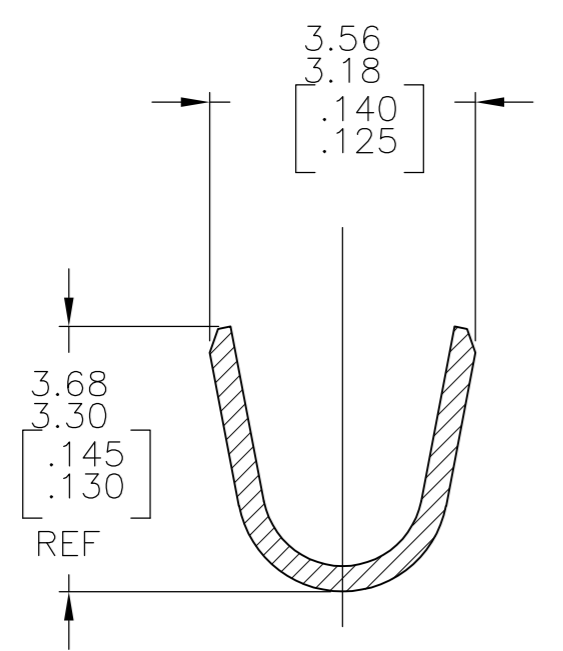

SECTION B-B
SCALE 10:1

5	GOLD	4	0.30 [0.012]	BRASS	1-770009-0
	GOLD	1	0.30 [0.012]	BRASS	-770009-2-
	PRE-TIN		0.30 [0.012]	BRASS	770009-1
	FINISH			MATERIAL	PART NUMBER

THIS DRAWING IS A CONTROLLED DOCUMENT.		DWN	S. CARPENTER	20MAY03	 TE Connectivity								
DIMENSIONS: mm [INCHES]		CHK	C. JONES	20MAY03									
TOLERANCES UNLESS OTHERWISE SPECIFIED:		APVD	C. JONES	20MAY03									
0 PLC ± - 1 PLC ± - 2 PLC ± - 3 PLC ± - 4 PLC ± - ANGLES ± -		PRODUCT SPEC	NAME										
MATERIAL	SEE TABLE	FINISH	SEE TABLE	WEIGHT	-	SIZE	A2	CAGE CODE	00779	DRAWING NO	C=770009	RESTRICTED TO	-
CUSTOMER DRAWING		SCALE		4:1	SHEET	1 OF 1	REV	G					