

# Parallel GLCD 128x64 Adapter™

## Manual

*All Mikroelektronika's development systems feature a large number of peripheral modules expanding microcontroller's range of application and making the process of program testing easier. In addition to these modules, it is also possible to use numerous additional modules linked to the development system through the I/O port connectors. Some of these additional modules can operate as stand-alone devices without being connected to the microcontroller.*

**Additional board**

 **MikroElektronika**

SOFTWARE AND HARDWARE SOLUTIONS FOR EMBEDDED WORLD ...making it simple

## Parallel GLCD 128x64 Adapter

The Parallel GLCD 128x64 Adapter additional board is used to connect a GLCD 128x64 display to a development system via parallel connection.

### Key features:

- Parallel communication;
- Display contrast adjustment;
- 5V power supply voltage.

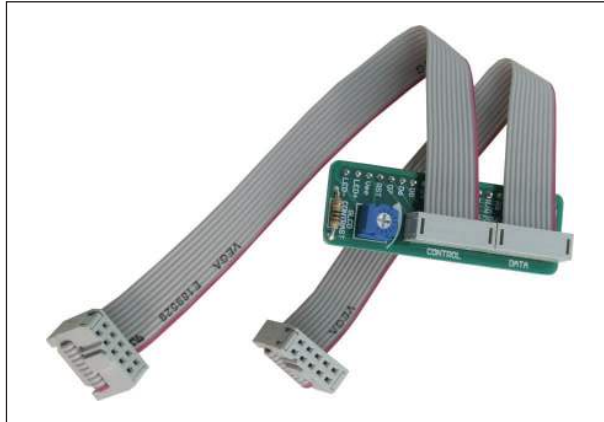

Figure 1: Parallel GLCD 128x64 Adapter

### How to connect the board?

The Parallel GLCD 128x64 Adapter board can be easily connected to a development system via IDC10 connectors CN1 and CN2 supplied on flat cables. The additional board is connected to the development system I/O ports. A 1x20 connector CN3 is used to connect a GLCD 128x64 display. Potentiometer P1 is used for display contrast adjustment.

Here you can find examples for the Parallel GLCD 128x64 Adapter board:  
<http://www.mikroe.com/eng/products/view/146/glcd-128x64-adapter-board/>

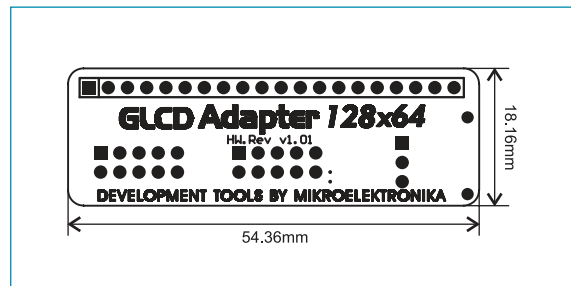
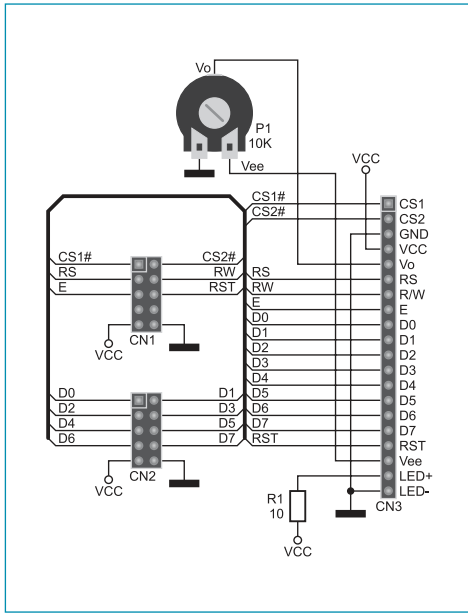

Figure 2: Dimensions of the board



**Figure 3:** Parallel GLCD 128x64 Adapter board connection schematic



**MikroElektronika**

SOFTWARE AND HARDWARE SOLUTIONS FOR EMBEDDED WORLD ...making it simple

If you want to learn more about our products, please visit our website at [www.mikroe.com](http://www.mikroe.com)

If you are experiencing some problems with any of our products or just need additional information, please place your ticket at [www.mikroe.com/en/support](http://www.mikroe.com/en/support)

If you have any questions, comments or business proposals, do not hesitate to contact us at [office@mikroe.com](mailto:office@mikroe.com)