

DESCRIPTION

The EV3900DK-00F is an evaluation board for the MP3900DK. It is configured to provide a regulated 25V output at up to 2A load current from a 12V input. The output is adjustable by changing feedback resistors on the evaluation board. MOSFET $R_{ds,on}$ can be directly used for current sense purpose without an external sense resistor.

Although the demo board uses the external 20m Ω to sense the current, it also provides the stuffing option for users who want to use the $R_{DS(ON)}$ as the sense element.

ELECTRICAL SPECIFICATIONS

Parameter	Symbol	Value	Units
Input voltage	V_{IN}	10~20	V
Input current	I_{IN}	0~6	A
Output voltage	V_O	25	V
Output Current	I_o	2	A

FEATURES

- Current Mode Control
- Undervoltage Lockout
- Cycle-by-Cycle Current Limiting
- Lossless Current Sense ($V_{ISENSE} < 30V$)
- 10 μ A Shutdown Current
- 180 μ A Quiescent Current
- 330KHz Constant Frequency Operation

APPLICATIONS

- TV CCFL Power Generation
- Telecom Isolated Power
- Brick Modules

"MPS" and "The Future of Analog IC Technology" are Registered Trademarks of Monolithic Power Systems, Inc.

EV3900DK-00F EVALUATION BOARD



(L x W x H) 1.8" x 1.8" x 0.4"
4.6cm x 4.6cm x 1.0cm

Board Number	MPS IC Number
EV3900DK-00F	MP3900DK

Efficiency vs. Output Current

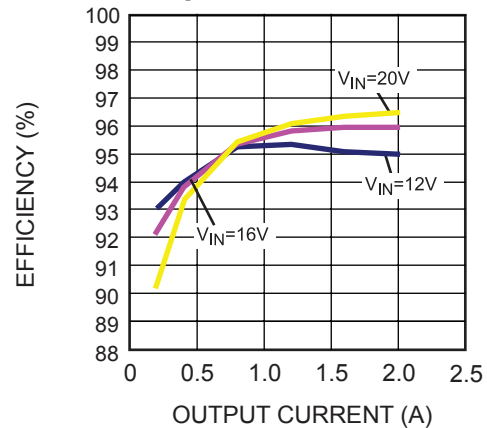

EVALUATION BOARD SCHEMATIC

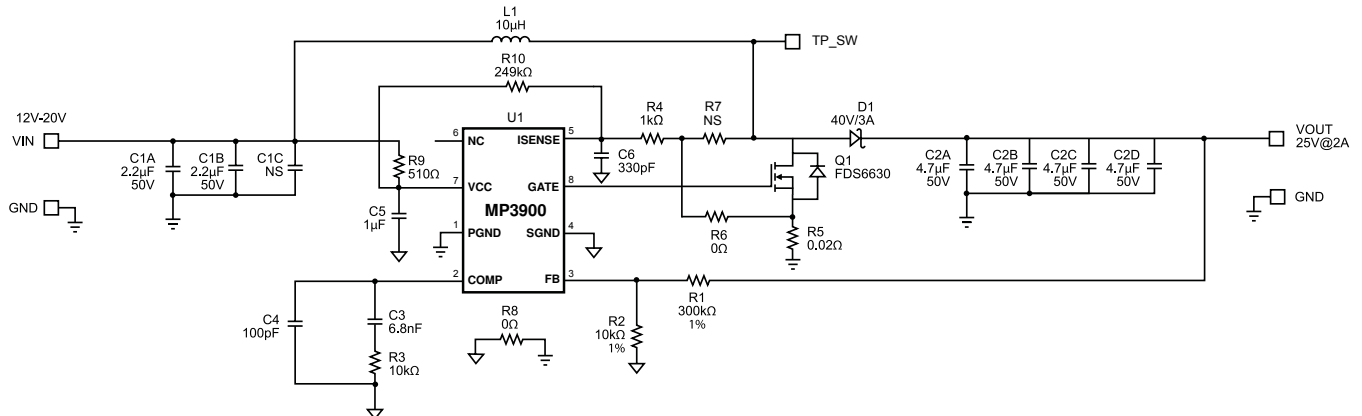

EV3900DK-00F BILL OF MATERIALS

Qty	Ref	Value	Description	Package	Manufacturer	Manufacturer P/N
2	C1A, C1B	2.2uF	Ceramic Cap., 50V, X7R	1210	TDK	C3225X7R1H225K
1	C1C	NS	Not Stuffed			
4	C2A, C2B, C2C, C2D	4.7uF	Ceramic Cap., 50V, X7R	1210	muRata	GRM32ER71H475KA8 8L
1	C3	6.8nF	Ceramic Cap., 50V, X7R	0603	TDK	C1608X7R1H682K
1	C4	100pF	Ceramic Cap., 50V, X7R	0603	TDK	C1608X7R1H101K
1	C5	1uF	Ceramic Cap., 16V, X7R	0603	TDK	C1608X7R1C105K
1	C6	330p	Ceramic Cap., 50V, X7R	0603	TDK	C1608X7R1H331K
1	D1	MBRA340T3	Diode Schottky, 40V, 3A	SMA	ON Semiconductor	MBRA340T3
1	Q1	FDS6630	MOSFET, N-CH, 30V, 6.5A	SO-8	Fairchild	FDS6630
1	L1	10uH	Inductor, 6.2A	SMD	Würth	74477010
1	R1	300kΩ	Film Res., 1%	0603	Yageo	RC0603FR-07300KL
2	R2, R3	10kΩ	Film Res., 1%	0603	Yageo	RC0603FR-0710KL
1	R4	1kΩ	Film Res., 1%	0603	Yageo	RC0603FR-071KL
2	R6, R8	0Ω	Film Res., 5%	0603	Yageo	RC0603JR-070RL
1	R5	0.020Ω	Strip Res., 5%	1206	CYNTEC	RL1632H-R020-FN
1	R7	NS	Not Stuffed			
1	R9	510Ω	Film Res., 5%	0805	Yageo	RC0805JR-07510RL
1	R10	249kΩ	Film Res., 1%	0603	Yageo	RC0603FR-07249KL
1	U1		DC-DC Converter	MSOP8	Monolithic Power Systems	MP3900DK-LF

PRINTED CIRCUIT BOARD LAYOUT

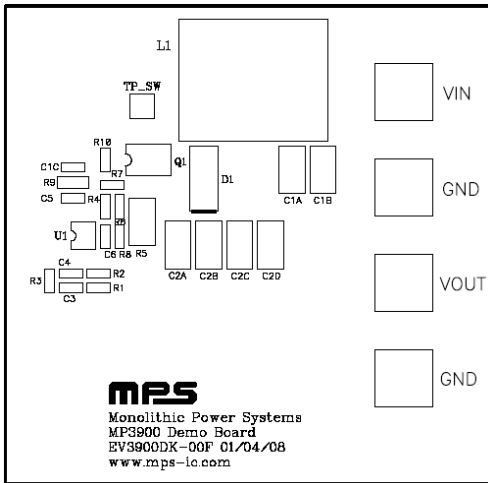

Figure 1—Top Silk Layer

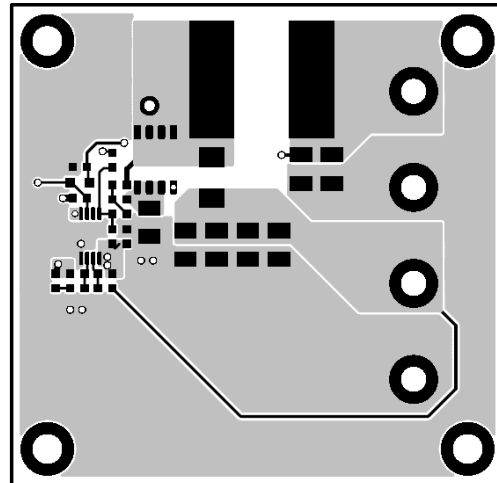

Figure 2—Top Layer

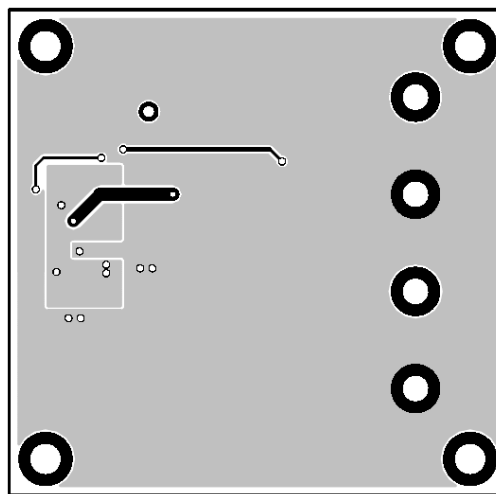

Figure 3—Bottom Layer

QUICK START GUIDE

1. The output voltage of this board is set to 25V. The board layout accommodates most commonly used inductors and output capacitors.
2. Preset Power Supply to $10V \leq V_{IN} \leq 20V$.
3. Turn Power Supply off.
4. Connect the power supply terminals to:
Positive (+): VIN
Negative (-): GND
Connect the load to:
Positive (+): VOUT
Negative (-): GND
Load current is up to 2A.
5. Turn on the power supply after making connections.
6. The MP3900 is enabled automatically on the evaluation board once VIN is applied. To disable the MP3900, just turn off the power supply or pull COMP low.
7. The output voltage VOUT can be changed by varying R1. Calculate the new value using the formula:

$$R1 = (V_{OUT}/V_{FB} - 1) \times R2$$

Where $V_{FB} = 0.8V$ and $R2 = 10k\Omega$

For example, for $V_{OUT} = 25V$

$$R1 = (25V/0.8V - 1) \times 10k\Omega = 302.5k\Omega$$

Therefore use a 300k Ω standard 1% value.

8. If MOSFET $R_{DS(ON)}$ sense is preferred, remove R6 and put R7 with 0 Ω .

NOTICE: The information in this document is subject to change without notice. Users should warrant and guarantee that third party Intellectual Property rights are not infringed upon when integrating MPS products into any application. MPS will not assume any legal responsibility for any said applications.