

THS6072
***Dual High-Speed Operational
Amplifier Evaluation Module***

User's Guide

IMPORTANT NOTICE

Texas Instruments and its subsidiaries (TI) reserve the right to make changes to their products or to discontinue any product or service without notice, and advise customers to obtain the latest version of relevant information to verify, before placing orders, that information being relied on is current and complete. All products are sold subject to the terms and conditions of sale supplied at the time of order acknowledgment, including those pertaining to warranty, patent infringement, and limitation of liability.

TI warrants performance of its semiconductor products to the specifications applicable at the time of sale in accordance with TI's standard warranty. Testing and other quality control techniques are utilized to the extent TI deems necessary to support this warranty. Specific testing of all parameters of each device is not necessarily performed, except those mandated by government requirements.

Customers are responsible for their applications using TI components.

In order to minimize risks associated with the customer's applications, adequate design and operating safeguards must be provided by the customer to minimize inherent or procedural hazards.

TI assumes no liability for applications assistance or customer product design. TI does not warrant or represent that any license, either express or implied, is granted under any patent right, copyright, mask work right, or other intellectual property right of TI covering or relating to any combination, machine, or process in which such semiconductor products or services might be or are used. TI's publication of information regarding any third party's products or services does not constitute TI's approval, warranty or endorsement thereof.

Preface

Related Documentation From Texas Instruments

- ***THS6072 LOW-POWER ADSL DIFFERENTIAL RECEIVER***
(literature number SLOS290) This is the data sheet for the THS6072 operational amplifier integrated circuit that is used in the THS6072 evaluation module.

FCC Warning

This equipment is intended for use in a laboratory test environment only. It generates, uses, and can radiate radio frequency energy and has not been tested for compliance with the limits of computing devices pursuant to subpart J of part 15 of FCC rules, which are designed to provide reasonable protection against radio frequency interference. Operation of this equipment in other environments may cause interference with radio communications, in which case the user at his own expense will be required to take whatever measures may be required to correct this interference.

Trademarks

TI is a trademark of Texas Instruments Incorporated.

PowerPAD is a trademark of Texas Instruments Incorporated.



Contents

1	General	1-1
1.1	Feature Highlights	1-2
1.2	Description	1-2
1.3	THS6072 EVM Noninverting Operation	1-3
1.4	Using the THS6072 EVM in the Noninverting Mode	1-5
1.5	THS6072 EVM Inverting Operation	1-6
1.6	Using the THS6072 EVM in the Inverting Mode	1-8
1.7	THS6072 EVM Differential Input	1-9
	1.7.1 Differential Input, Noninverting Operation	1-9
	1.7.2 Differential Input, Inverting Operation	1-11
1.8	Using the THS6072 EVM With Differential Inputs	1-13
1.9	THS6072 EVM Specifications	1-14
1.10	THS6072 EVM Performance	1-14
1.11	General High-Speed Amplifier Design Considerations	1-16
1.12	General PowerPAD™ Design Considerations	1-17
2	Reference	2-1
2.1	THS6072 EVM Schematic	2-2
2.2	THS6072 Dual High-Speed Operational Amplifier EVM Parts List	2-3
2.3	THS6072 EVM Board Layouts	2-4

Figures

1-1	THS6072 Evaluation Module	1-3
1-2	THS6072 EVM Schematic: Noninverting Operation	1-4
1-3	THS6072 EVM Schematic: Inverting Operation	1-7
1-4	THS6072 EVM Schematic: Differential Input (Noninverting Operation)	1-10
1-5	THS6072 EVM Schematic: Differential Input (Inverting Operation)	1-12
1-6	THS6072 EVM Frequency Response With Gain = 2	1-15
1-7	THS6072 EVM Phase Response With Gain = 2	1-15
1-8	PowerPAD™ PCB Etch and Via Pattern	1-17
1-9	Maximum Power Dissipation vs Free-Air Temperature	1-18
2-1	THS6072 EVM Schematic	2-2
2-2	THS6072 EVM Component Placement Silkscreen and Solder Pads	2-4
2-2	THS6072 EVM PC Board Layout: Component Side	2-5
2-3	THS6072 EVM PC Board Layout: Back Side	2-6

Tables

2-1	THS6072 EVM Parts List	2-3
-----	------------------------------	-----

General

This chapter details the Texas Instruments (TI) THS6072 low-power ADSL differential receiver evaluation module (EVM), SLOP322. It includes a list of EVM features, a brief description of the module illustrated with a pictorial and a schematic diagram, EVM specifications, details on connecting and using the EVM, and discussions on high-speed amplifier design and thermal considerations.

Topic	Page
1.1 Feature Highlights	1-2
1.2 Description	1-2
1.3 THS6072 EVM Noninverting Operation	1-3
1.4 Using the THS6072 EVM in the Noninverting Mode	1-5
1.5 THS6072 EVM Inverting Operation	1-6
1.6 Using the THS6072 EVM in the Inverting Mode	1-8
1.7 THS6072 EVM Differential Input	1-9
1.8 Using the THS6072 EVM With Differential Inputs	1-13
1.9 THS6072 EVM Specifications	1-14
1.10 THS6072 EVM Performance	1-14
1.11 General High-Speed Amplifier Design Considerations	1-16
1.12 General PowerPAD™ Design Considerations	1-17

1.1 Feature Highlights

THS6072 dual high-speed operational amplifier EVM features include:

- High Bandwidth: 70 MHz, -3 dB at ± 15 V_{CC} and Gain = 2
- ± 5 -V to ± 15 -V Operation
- Noninverting Single-Ended Inputs: Inverting-Capable Through Component Change
- Module Gain Set to 2 (Noninverting): Adjustable Through Component Change
- Nominal 50- Ω Impedance Inputs and Outputs
- Standard BNC Input and Output Connectors
- Good Example of High-Speed Amplifier Design and Layout

1.2 Description

The THS6072 dual high-speed operational amplifier evaluation module (EVM) is a complete dual high-speed amplifier circuit. It consists of the THS6072 dual low-noise high-speed operational amplifier IC, along with a small number of passive parts, mounted on a small circuit board measuring approximately 1.9 inch by 2.2 inch (Figure 1–1). The EVM uses standard BNC connectors for inputs and outputs and is completely assembled, tested, and ready to use — just connect it to power, a signal source, and a load (if desired).

Figure 1–1. THS6072 Evaluation Module

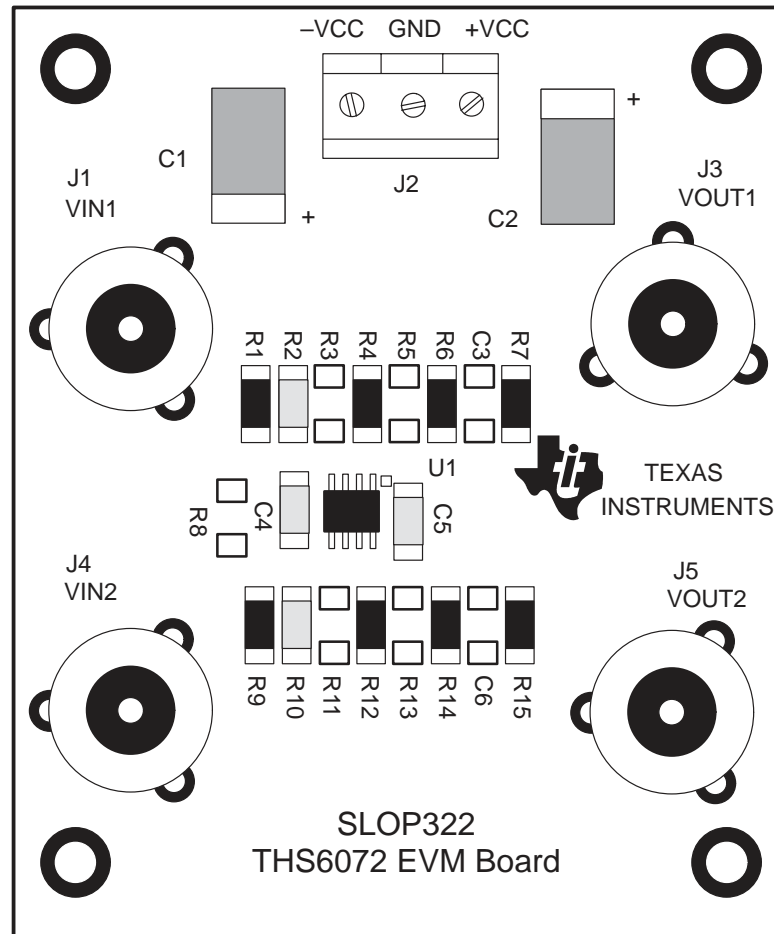

Note: The EVM is shipped with the following component locations empty:
C3, C6, R2, R4, R8, R10, and R12

Although the THS6072 EVM is shipped with components installed for dual-channel single-ended noninverting operation, it can also be configured for single-channel differential and/or inverting operation by moving components. Noninverting gain is set to 2 with the installed components. The input of each channel is terminated with a 50- Ω impedance to provide the correct line impedance matching. The amplifier IC outputs are routed through 50- Ω resistors, both to provide correct line impedance matching and to help isolate capacitive loading on the outputs of the amplifier. Capacitive loading directly on the output of the IC decreases the amplifier's phase margin and can result in peaking or oscillations.

1.3 THS6072 EVM Noninverting Operation

The THS6072 EVM is shipped preconfigured for dual-channel noninverting operation, as shown in Figure 1–2.

Note:

Compensation capacitors C3 and C6 are not installed.

Figure 1–2. THS6072 EVM Schematic: Noninverting Operation

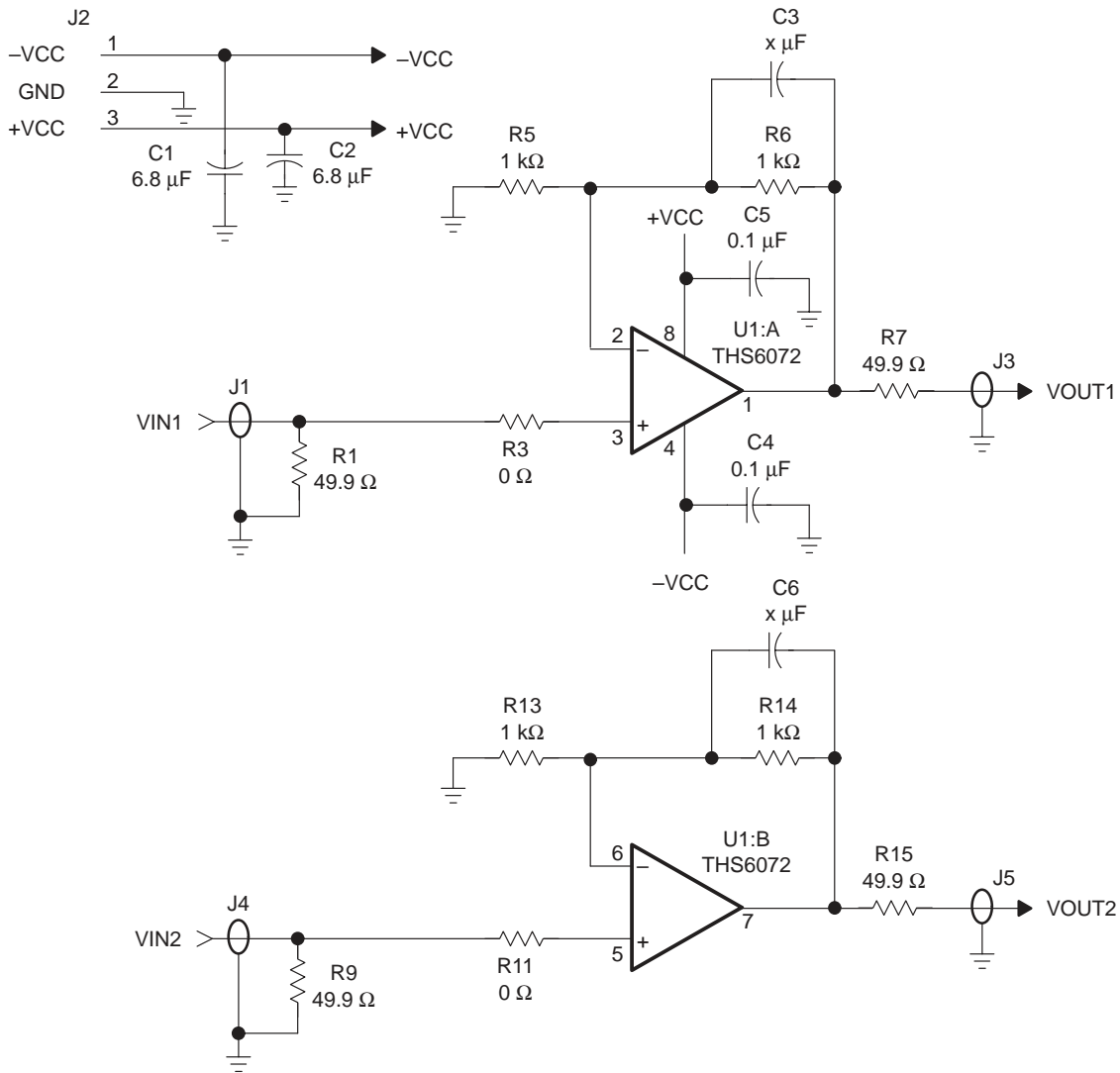

The gain of the EVM can easily be changed to support a particular application by simply changing the ratio of resistors R6 and R5 (channel 1) and R14 and R13 (channel 2) as described in the following equation:

$$\text{Noninverting Gain} = 1 + \frac{R_F}{R_G} = 1 + \frac{R6}{R5} \text{ and } 1 + \frac{R14}{R13}$$

In addition, some applications, such as those for video, may require the use of 75-Ω cable and a 75-Ω EVM input termination and output isolation resistors.

Any of the resistors on the EVM board can be replaced with a resistor of a different value; however, care must be taken because the surface-mount solder pads on the board are somewhat fragile and will not survive many desoldering/soldering operations.

Note:

External factors can significantly affect the effective gain of the EVM. For example, connecting test equipment with 50- Ω input impedance to the EVM output will divide the output signal level by a factor of 2 (assuming the output isolation resistor on the EVM board remains 50 Ω). Similar effects can occur at the input, depending upon how the input signal sources are configured. The gain equations given above assume no signal loss in either the input or the output.

Frequency compensation capacitors C3 and C6 may need to be installed to improve stability at lower gains. The appropriate value depends on the particular application.

The EVM circuit board is an excellent example of proper board layout for high-speed amplifier designs and can be used as a guide for user application board layouts.

1.4 Using the THS6072 EVM in the Noninverting Mode

The THS6072 EVM operates from power-supply voltages ranging from ± 5 V to ± 15 V. As shipped, the EVM is configured for noninverting operation and the gain is set to 2. Signal inputs on the module are terminated for 50- Ω nominal source impedance. An oscilloscope is typically used to view and analyze the EVM output signal.

- 1) Ensure that all power supplies are set to OFF before making power supply connections to the THS6072 EVM.
- 2) Connect the power supply ground to the module terminal block (J2) location marked GND.
- 3) Select the operating voltage for the EVM and connect appropriate split power supplies to the module terminal block (J2) locations marked $-VCC$ and $+VCC$.
- 4) Connect an oscilloscope to the module BNC output connector (J3/J5) through a 50- Ω nominal impedance cable (an oscilloscope having a 50- Ω input termination is preferred for examining very high frequency signals).
- 5) Set the power supply to ON.
- 6) Connect the signal input to the module BNC input connector (J1/J4).

Note:

Each EVM input connector is terminated with a 50- Ω impedance to ground. With a 50- Ω source impedance, the voltage seen by the THS6072 amplifier IC on the module will be 1/2 the source signal voltage applied to the EVM. This is due to the voltage division between the source impedance and the EVM input terminating resistors (R1, R9).

- 7) Verify the output signal on the oscilloscope.

Note:

The signal shown on an oscilloscope with a 50- Ω input impedance will be 1/2 the actual THS6072 amplifier IC output voltage. This is due to the voltage division between the output resistor (R7, R15) and the oscilloscope input impedance.

1.5 THS6072 EVM Inverting Operation

Although the THS6072 EVM is shipped preconfigured for dual-channel noninverting operation, it can be reconfigured for inverting operation by making the following component changes:

- 1) Move resistor R3 to the R2 location and R5 to the R4 location on the board.
- 2) Move resistor R11 to the R10 location and R13 to the R12 location on the board.

This configuration is shown in Figure 1–3.

Note:

Compensation capacitors C3 and C6 are not installed.

Figure 1–3. THS6072 EVM Schematic: Inverting Operation

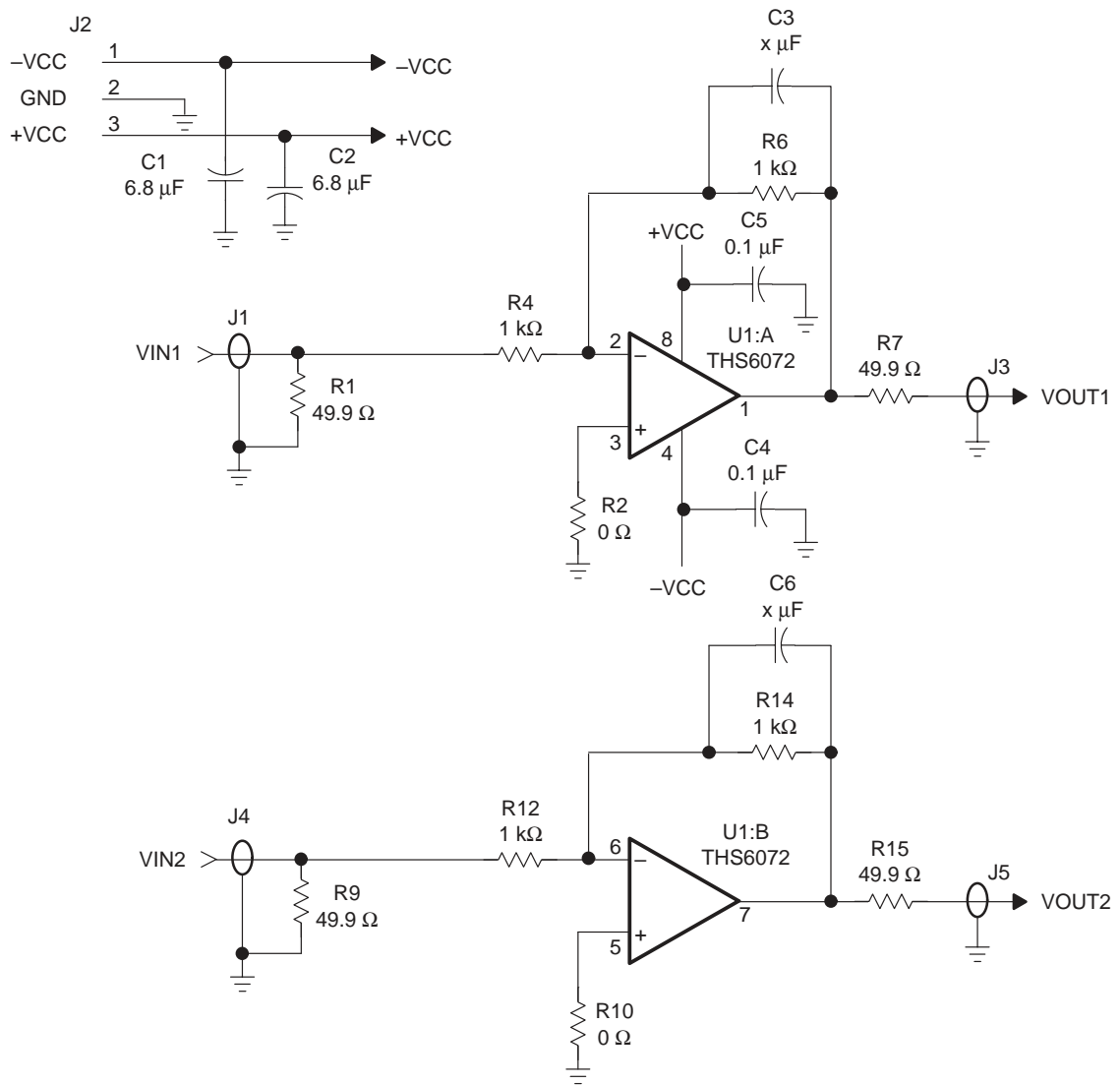

The gain of the EVM can easily be changed to support a particular application by simply changing the ratio of resistors R6 and R4 (channel 1) and R14 and R12 (channel 2) as described in the following equation:

$$\text{Inverting Gain} = \frac{-R_F}{R_G} = \frac{-R6}{R4} \text{ and } \frac{-R14}{R12}$$

In addition, some applications, such as those for video, may require the use of 75-Ω cable and 75-Ω EVM input termination and output isolation resistors.

Because the noninverting terminals are at ground potential, the inverting terminal becomes a *virtual ground* and is held to 0 V. This causes the input impedance to ground at the input terminal to look like two resistors in parallel (R1 and R4 for channel 1, and R9 and R12 for channel 2). As a result, if the source termination is changed, R1 and R9 must be adjusted in accordance with the following equations:

$$R1 = \frac{R4 \times R_T}{R4 - R_T} \text{ (Channel 1) and } R9 = \frac{R12 \times R_T}{R4 - R_T} \text{ (Channel 2)}$$

where R_T is the source impedance.

Any of the resistors on the EVM board can be replaced with a resistor of a different value; however, care must be taken because the surface-mount solder pads on the board are somewhat fragile and will not survive many desoldering/soldering operations.

Note:

External factors can significantly affect the effective gain of the EVM. For example, connecting test equipment with 50- Ω input impedance to the EVM output will divide the output signal level by a factor of 2 (assuming the output isolation resistor on the EVM board remains 50 Ω). Similar effects can occur at the input, depending upon how the input signal sources are configured. The gain equations given above assume no signal loss in either the input or the output.

Frequency compensation capacitors C3 and C6 may need to be installed to improve stability at lower gains. The appropriate value depends on the particular application.

The EVM circuit board is an excellent example of proper board layout for high-speed amplifier designs and can be used as a guide for user application board layouts.

1.6 Using the THS6072 EVM in the Inverting Mode

The THS6072 EVM operates from power-supply voltages ranging from ± 5 V to ± 15 V. As shipped, the EVM is configured for inverting operation. Move the resistors as detailed above to configure the EVM for noninverting operation, which sets the gain to -3 . Signal inputs on the module are terminated for 50- Ω nominal source impedance. An oscilloscope is typically used to view and analyze the EVM output signal.

- 1) Ensure that all power supplies are set to OFF before making power supply connections to the THS6072 EVM.
- 2) Connect the power supply ground to the module terminal block (J2) location marked *GND*.
- 3) Select the operating voltage for the EVM and connect appropriate split power supplies to the module terminal block (J2) locations marked $-VCC$ and $+VCC$.

- 4) Connect an oscilloscope to the module BNC output connector (J3/J5) through a 50- Ω nominal impedance cable (an oscilloscope having a 50- Ω input termination is preferred for examining very high frequency signals).
- 5) Set the power supply to ON.
- 6) Connect the signal input to the module BNC input connector (J1/J2).

Note:

Each EVM input connector is terminated with an equivalent 50- Ω impedance to ground. With a 50- Ω source impedance, the voltage seen by the THS6072 amplifier IC on the module will be 1/2 the source signal voltage applied to the EVM. This is due to the voltage division between the source impedance and the EVM input terminating resistors (R1 || R4 and R9 || R12).

- 7) Verify the output signal on the oscilloscope.

Note:

The signal shown on an oscilloscope with a 50- Ω input impedance will be 1/2 the actual THS6072 amplifier IC output voltage. This is due to the voltage division between the output resistor (R7, R15) and the oscilloscope input impedance.

1.7 THS6072 EVM Differential Input

The THS6072 EVM is shipped preconfigured for dual-channel, single-ended noninverting operation. It can be reconfigured for single-channel, differential operation, either non inverting or inverting.

1.7.1 Differential Input, Noninverting Operation

Configure the THS6072 EVM for differential noninverting operation by removing two resistors and adding a resistor on the board:

- 1) Remove resistors R1 and R9.
- 2) Add a 100- Ω resistor to the R8 location on the board.

This configuration (noninverting) is shown in Figure 1–4. For a noninverting differential input, R8 should be 100 Ω to match 50- Ω source impedances.

Note:

Compensation capacitors C3 and C6 are not installed.

Figure 1–4. THS6072 EVM Schematic: Differential Input (Noninverting Operation)

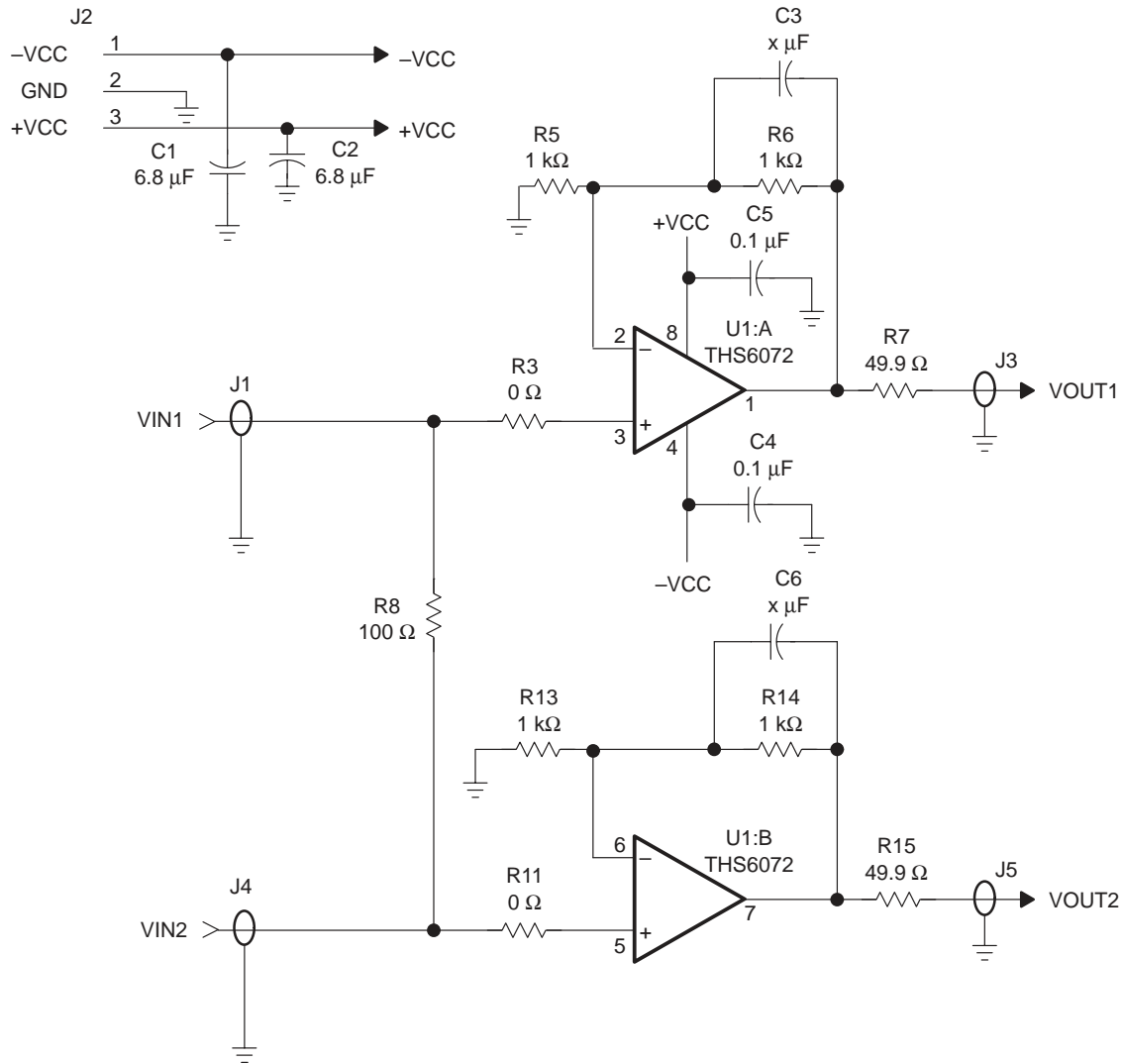

The gain of the EVM can easily be changed to support a particular application by simply changing the ratio of resistors R6 and R5 (channel 1) and R14 and R13 (channel 2) as described in the following equation:

$$\text{Noninverting Gain} = 1 + \frac{R_F}{R_G} = 1 + \frac{R6}{R5} \text{ and } 1 + \frac{R14}{R13}$$

In addition, some applications, such as those for video, may require the use of 75-Ω cable and 75-Ω EVM input termination and output isolation resistors.

Any of the resistors on the EVM board can be replaced with a resistor of a different value; however, care must be taken because the surface-mount solder pads on the board are somewhat fragile and will not survive many desoldering/soldering operations.

Note:

External factors can significantly affect the effective gain of the EVM. For example, connecting test equipment with 50- Ω input impedance to the EVM output will divide the output signal level by a factor of 2 (assuming the output isolation resistor on the EVM board remains 50 Ω). Similar effects can occur at the input, depending upon how the input signal sources are configured. The gain equations given above assume no signal loss in either the input or the output.

Frequency compensation capacitors C3 and C6 may need to be installed to improve stability at lower gains. The appropriate value depends on the particular application.

The EVM circuit board is an excellent example of proper board layout for high-speed amplifier designs and can be used as a guide for user application board layouts.

1.7.2 Differential Input, Inverting Operation

Configure the THS6072 EVM for differential inverting operation by removing two resistors and adding a resistor on the board:

- 1) Move resistor R3 to the R2 location and R5 to the R4 location on the board.
- 2) Move resistor R11 to the R10 location and R13 to the R12 location on the board.
- 3) Remove resistors R1 and R9.
- 4) Add a 100- Ω resistor to the R8 location on the board.

This configuration (inverting) is shown in Figure 1–5.

Note:

Compensation capacitors C3 and C6 are not installed.

Figure 1–5. THS6072 EVM Schematic: Differential Input (Inverting Operation)

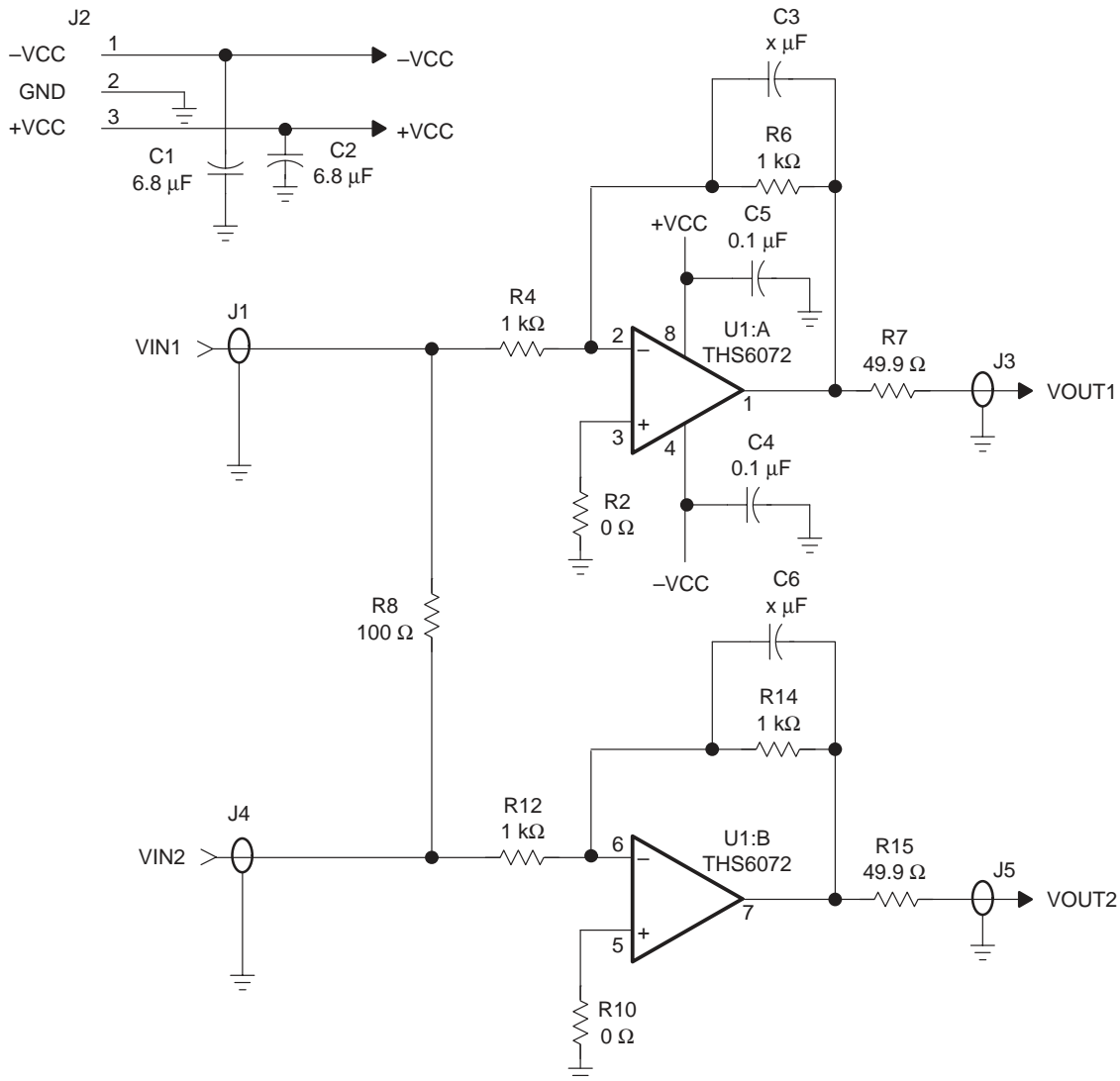

The gain of the EVM inputs can easily be changed to support a particular application by simply changing the ratio of resistors R6 and R4 (channel 1) and R14 and R12 (channel 2) as described in the following equation:

$$\text{Inverting Gain} = \frac{-R_F}{R_G} = \frac{-R6}{R4} \text{ and } \frac{-R14}{R12}$$

Note that R4 and R12 form part of the input impedance and R8 should be adjusted in accordance with the following equation:

$$R8 = \frac{2 R4 \times R_T}{R4 - R_T}$$

where R_T is the termination resistance and $R4 = R12$.

In addition, some applications, such as those for video, may require the use of 75-Ω cable and 75-Ω EVM input termination and output isolation resistors.

Any of the resistors on the EVM board can be replaced with a resistor of a different value; however, care must be taken because the surface-mount solder pads on the board are somewhat fragile and will not survive many desoldering/soldering operations.

Note:

External factors can significantly affect the effective gain of the EVM. For example, connecting test equipment with 50- Ω input impedance to the EVM output will divide the output signal level by a factor of 2 (assuming the output isolation resistor on the EVM board remains 50 Ω). Similar effects can occur at the input, depending upon how the input signal sources are configured. The gain equations given above assume no signal loss in either the input or the output.

Frequency compensation capacitors C3 and C6 may need to be installed to improve stability at lower gains. The appropriate value depends on the particular application.

The EVM circuit board is an excellent example of proper board layout for high-speed amplifier designs and can be used as a guide for user application board layouts.

1.8 Using the THS6072 EVM With Differential Inputs

The THS6072 EVM operates from power-supply voltages ranging from ± 5 V to ± 15 V. Move resistors on the board as detailed above for either noninverting or inverting operation to configure the EVM for differential input operation. Signal inputs on the module are terminated for 50- Ω nominal source impedance. An oscilloscope is typically used to view and analyze the EVM output signal.

- 1) Ensure that all power supplies are set to OFF before making power supply connections to the THS6072 EVM.
- 2) Connect the power supply ground to the module terminal block (J2) location marked GND.
- 3) Select the operating voltage for the EVM and connect appropriate split power supplies to the module terminal block (J2) locations marked $-VCC$ and $+VCC$.
- 4) Connect an oscilloscope across the module BNC output connectors (J3 and J5) through a 50- Ω nominal impedance cable (an oscilloscope having a 50- Ω input termination is preferred for examining very high frequency signals).
- 5) Set the power supply to ON.
- 6) Connect the differential signal input across the module BNC input connectors (J1 and J4).

Note:

The differential EVM input is terminated with an equivalent 50-Ω impedance for each input. With a 50-Ω source impedance, the voltage seen by the THS6072 amplifier IC on the module will be 1/2 the source signal voltage applied to the EVM. This is due to the voltage division between the source impedance and the EVM equivalent input resistance.

- 7) Verify the differential output signal on the oscilloscope.

Note:

The signal shown on an oscilloscope with a 50-Ω input impedance will be 1/4 the actual THS6072 amplifier IC output voltage. This is due to the voltage division between the output resistors (R7, R15) and the oscilloscope input impedance.

1.9 THS6072 EVM Specifications

Supply voltage range, $\pm V_{CC}$	$\pm 5\text{ V}$ to $\pm 15\text{ V}$
Supply current, I_{CC}	7 mA typ
Input voltage, V_I	$\pm V_{CC}$, max
Output drive, I_O	65 mA

For complete THS6072 amplifier IC specifications, parameter measurement information, and additional application information, see the THS6072 data sheet, TI Literature Number SLOS290.

1.10 THS6072 EVM Performance

Figure 1–6 shows the typical frequency response of the THS6072 EVM using the noninverting configuration ($G = 2$). Typical –3-dB bandwidth is 70 MHz with both a $\pm 15\text{-V}$ power supply and a $\pm 5\text{-V}$ power supply.

Figure 1–6. THS6072 EVM Frequency Response With Gain = 2

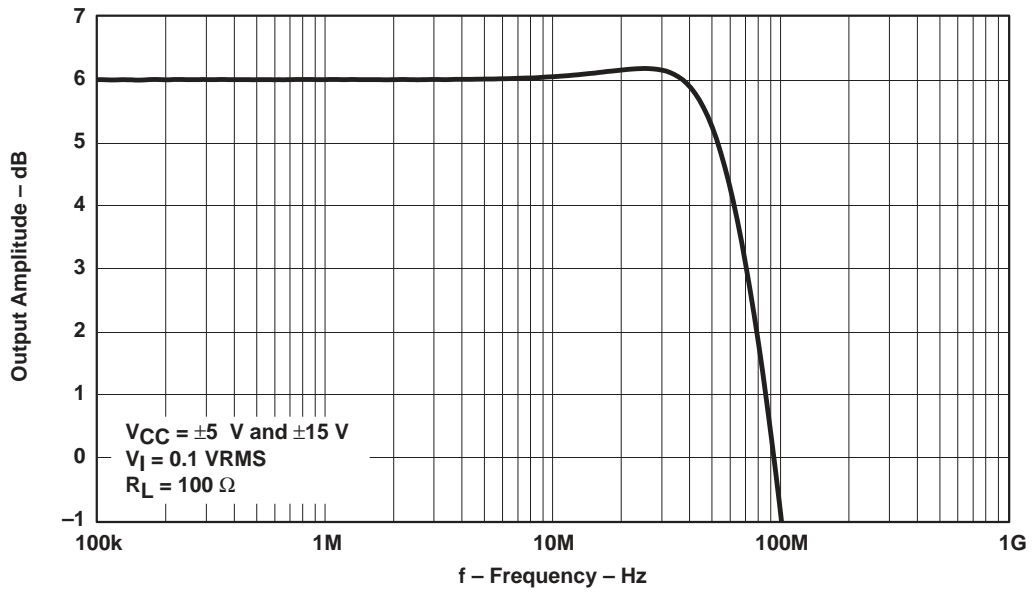
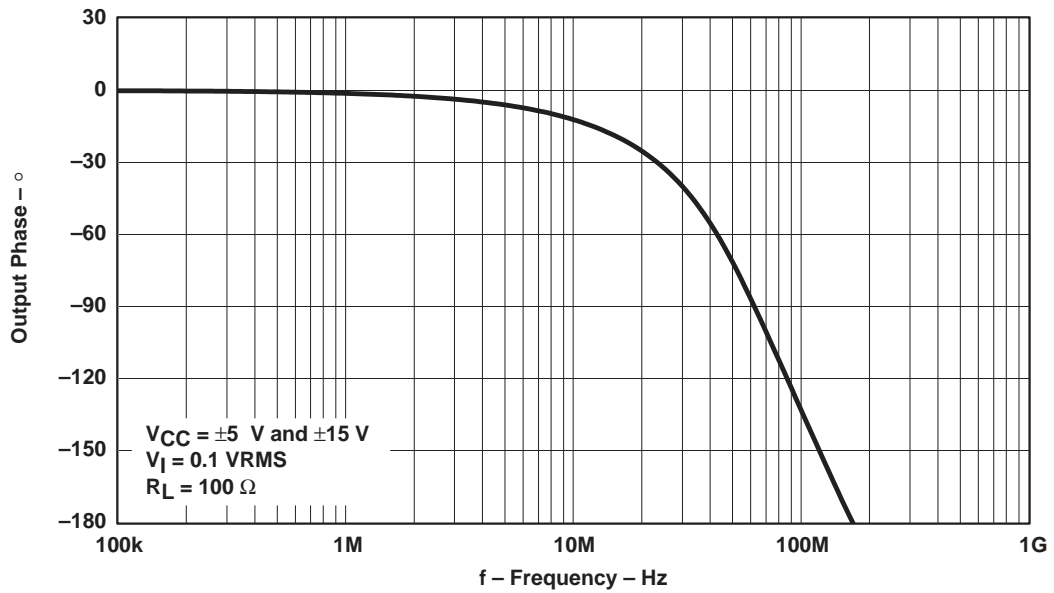

Figure 1–7 shows the typical phase response of the THS6072 EVM using the noninverting configuration (G = 2).

Figure 1–7. THS6072 EVM Phase Response With Gain = 2



1.11 General High-Speed Amplifier Design Considerations

The THS6072 EVM layout has been designed and optimized for use with high-speed signals and can be used as an example when designing THS6072 applications. Careful attention has been given to component selection, grounding, power supply bypassing, and signal path layout. Disregard of these basic design considerations could result in less than optimum performance of the THS6072 high-speed, low-power operational amplifier.

Surface-mount components were selected because of the extremely low lead inductance associated with this technology. Also, because surface-mount components are physically small, the layout can be very compact. This helps minimize both stray inductance and capacitance.

Tantalum power supply bypass capacitors (C1 and C2) at the power input pads help supply currents for rapid, large signal changes at the amplifier output. The 0.1 μF power supply bypass capacitors (C4 and C5) were placed as close as possible to the IC power input pins in order to keep the PCB trace inductance to a minimum. This improves high-frequency bypassing and reduces harmonic distortion.

A proper ground plane on both sides of the PCB should always be used with high-speed circuit design. This provides low-inductive ground connections for return current paths. In the area of the amplifier IC input pins, however, the ground plane was removed to minimize stray capacitance and reduce ground plane noise coupling into these pins. This is especially important for the inverting pin while the amplifier is operating in the noninverting mode. Because the voltage at this pin swings directly with the noninverting input voltage, any stray capacitance would allow currents to flow into the ground plane, causing possible gain error and/or oscillation. Capacitance variations at the amplifier IC input pin of less than 1 pF can significantly affect the response of the amplifier.

In general, it is always best to keep signal lines as short and as straight as possible. Round corners or a series of 45° bends should be used instead of sharp 90° corners. Stripline techniques should also be incorporated when signal lines are greater than 1 inch in length. These traces should be designed with a characteristic impedance of either 50 Ω or 75 Ω , as required by the application. Such signal lines should also be properly terminated with an appropriate resistor.

Finally, proper termination of all inputs and outputs should be incorporated into the layout. Unterminated lines, such as coaxial cable, can appear to be a reactive load to the amplifier IC. By terminating a transmission line with its characteristic impedance, the amplifier's load then appears to be purely resistive and reflections are absorbed at each end of the line. Another advantage of using an output termination resistor is that capacitive loads are isolated from the amplifier output. This isolation helps minimize the reduction in amplifier phase-margin and improves the amplifier stability for improved performance such as reduced peaking and settling times.

1.12 General PowerPAD™ Design Considerations

The THS6072DGN IC is mounted in a special package incorporating a thermal pad that transfers heat from the IC die directly to the PCB. The PowerPAD™ package is constructed using a downset leadframe. The die is mounted on the leadframe but is electrically isolated from it. The bottom surface of the lead frame is exposed as a metal thermal pad on the underside of the package and makes physical contact with the PCB. Because this thermal pad is in direct physical contact with both the die and the PCB, excellent thermal performance can be achieved by providing a good thermal path away from the thermal pad mounting point on the PCB.

Although there are many ways to properly heatsink this device, the following steps illustrate the recommended approach as used on the THS6072 EVM.

- 1) Prepare the PCB with a top side etch pattern as shown in Figure 1–8. There should be etch for the leads as well as etch for the thermal pad.

Figure 1–8. PowerPAD™ PCB Etch and Via Pattern

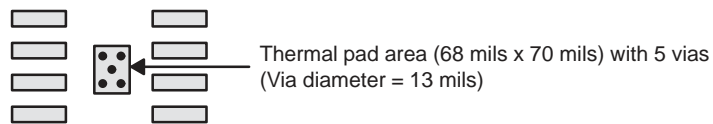

- 2) Place five holes in the area of the thermal pad. These holes should be 13 mils in diameter. They are kept small so that solder wicking through the holes is not a problem during reflow.
- 3) Additional vias may be placed anywhere along the thermal plane outside of the thermal pad area. This helps dissipate the heat generated by the THS6072DGN IC. These additional vias may be larger than the 13-mil diameter vias directly under the thermal pad. They can be larger because they are not in the thermal pad area to be soldered so that wicking is not a problem.
- 4) Connect all holes to the internal ground plane.
- 5) When connecting these holes to the ground plane, do not use the typical web or spoke via connection methodology. Web connections have a high thermal resistance connection that is useful for slowing the heat transfer during soldering operations. This makes the soldering of vias that have plane connections easier. In this application, however, low thermal resistance is desired for the most efficient heat transfer. Therefore, the holes under the THS6072DGN package should make their connection to the internal ground plane with a complete connection around the entire circumference of the plated-through hole.
- 6) The top-side solder mask should leave the terminals of the package and the thermal pad area with its five holes exposed. The bottom-side solder mask should cover the five holes of the thermal pad area. This prevents solder from being pulled away from the thermal pad area during the reflow process.
- 7) Apply solder paste to the exposed thermal pad area and all of the IC terminals.

- 8) With these preparatory steps in place, the THS6072DGN IC is simply placed in position and run through the solder reflow operation as any standard surface-mount component. This results in a part that is properly installed.

The actual thermal performance achieved with the THS6072DGN in its PowerPAD™ package depends on the application. In the example above, if the size of the internal ground plane is approximately 3 inches × 3 inches, then the expected thermal coefficient, θ_{JA} , is about 58.4°C/W. For comparison, the non-PowerPAD™ version of the THS6072 IC (D-package in SOIC) is shown. For a given θ_{JA} , the maximum power dissipation is shown in Figure 1–9 and is calculated by the following formula:

$$P_D = \left(\frac{T_{MAX} - T_A}{\theta_{JA}} \right)$$

Where:

- P_D = Maximum power dissipation of THS6072 IC (watts)
- T_{MAX} = Absolute maximum junction temperature (150°C)
- T_A = Free-ambient air temperature (°C)
- θ_{JA} = $\theta_{JC} + \theta_{CA}$
- θ_{JC} = Thermal coefficient from junction to case (4.7°C/W) for THS6072DGN (PowerPAD™)
- θ_{JC} = Thermal coefficient from junction to case (38.3°C/W) for THS6072D (SOIC)
- θ_{CA} = Thermal coefficient from case to ambient air (°C/W)

Figure 1–9. Maximum Power Dissipation vs Free-Air Temperature

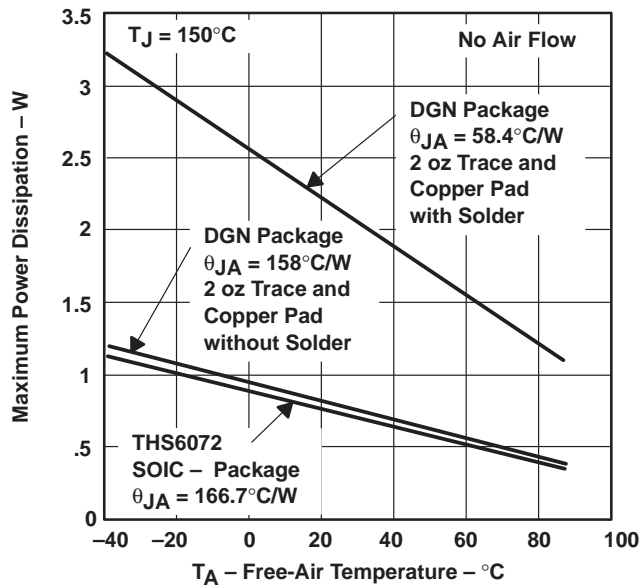

Even though the THS6072 EVM PCB is smaller than the one in the example above, the results should give an idea of how much power can be dissipated by the PowerPAD™ IC package. The THS6072 EVM is a good example of proper thermal management when using PowerPAD™-mounted devices.

Correct PCB layout and manufacturing techniques are critical for achieving adequate transfer of heat away from the PowerPAD™ IC package. More details on proper board layout can be found in the *THS6072 Low-Power ADSL Differential Receiver* data sheet (literature number SLOS216). For more general information on the PowerPAD package and its thermal characteristics, see the Texas Instruments Technical Brief, *PowerPAD™ Thermally Enhanced Package* (literature number SLMA002) and the *PowerPAD™ Made Easy* Application Brief (literature number SLMA004).



Reference

This chapter includes a complete schematic, parts list, and PCB layout illustrations for the THS6072 EVM.

Topic	Page
2.1 THS6072 EVM Schematic	2-2
2.1 THS6072 Dual High-Speed Operational Amplifier EVM Parts List ..	2-3
2.2 THS6072 EVM Board Layouts	2-4

2.1 THS6072 EVM Schematic

Figure 2–1 shows the complete THS6072 EVM schematic. The EVM is shipped preconfigured for dual-channel, single-ended inverting operation. Components showing a value of X are not supplied on the board, but can be installed by the user to reconfigure the EVM for noninverting and/or differential operation.

Figure 2–1. THS6072 EVM Schematic

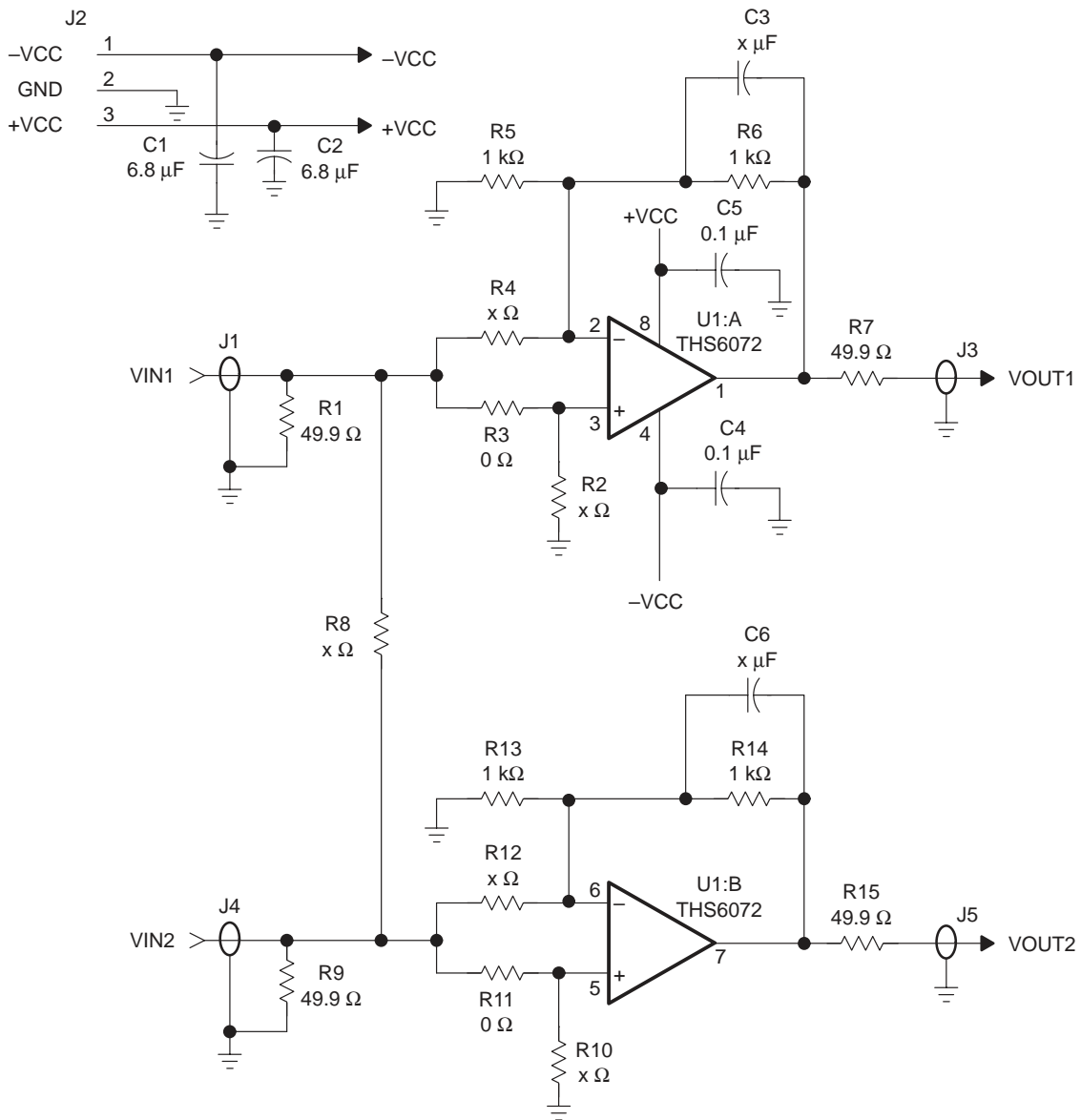

2.2 THS6072 Dual High-Speed Operational Amplifier EVM Parts List

Table 2–1. THS6072 EVM Parts List

Reference	Description	Size	Manufacturer/Supplier Part Number
C1, C2	Capacitor, 6.8 μ F, 35 V, Tantalum, SM		Sprague 293D685X9035D2T
C4, C5	Capacitor, 0.1 μ F, Ceramic, 10%, SM	1206	Murata GRM42X7R104K50
J2	3-Pin terminal block (On Shore Tech.)		Digi-Key ED1515–ND
J1, J3, J4, J5	Jack, BNC, PC-Mount (Amphenol)		Mouser 523–31–5329
R1, R7, R9, R15	Resistor, 49.9 Ω , 1%, 1/8 W, SM	1206	
R5, R6, R13, R14	Resistor, 1 k Ω , 1%, 1/8 W, SM	1206	
R3, R11	Resistor, 0 Ω , 1/8 W, SM	1206	
U1	IC, THS6072 amplifier	SOIC-8	TI THS6072DGN
R2, R4, R10, R12	Resistor, X Ω , 1%, 1/8 W, SM [†]	1206	
C3, C6	Capacitor, X μ F, 10%, Ceramic, SM [†]		
	4–40 Hex Standoffs, 0.625" length, 0.25" O.D.		
	4–40 Screws		
PCB1	PCB, THS6072 EVM		SLOP322

[†] These components are NOT supplied on the EVM and are to be determined and installed by the user to reconfigure the EVM in accordance with application requirements.

2.3 THS6072 EVM Board Layouts

Board layout examples of the THS6072 EVM PCB are shown in the following illustrations. They are not to scale and appear here only as a reference.

Figure 2–2. THS6072 EVM Component Placement Silkscreen and Solder Pads

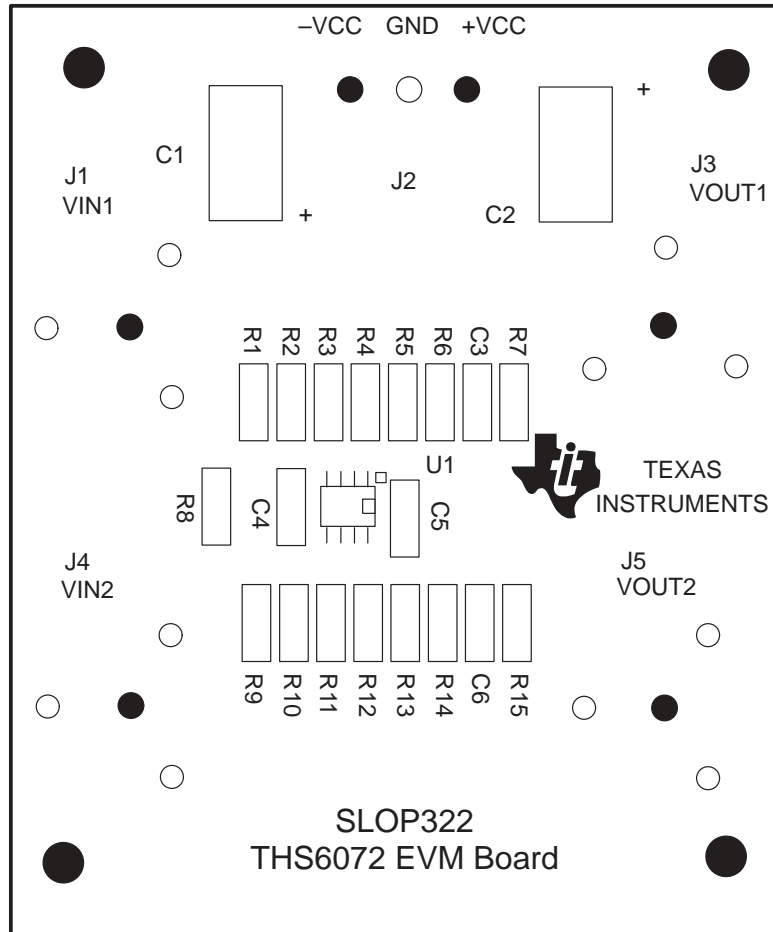

Figure 2–3. THS6072 EVM PC Board Layout: Component Side

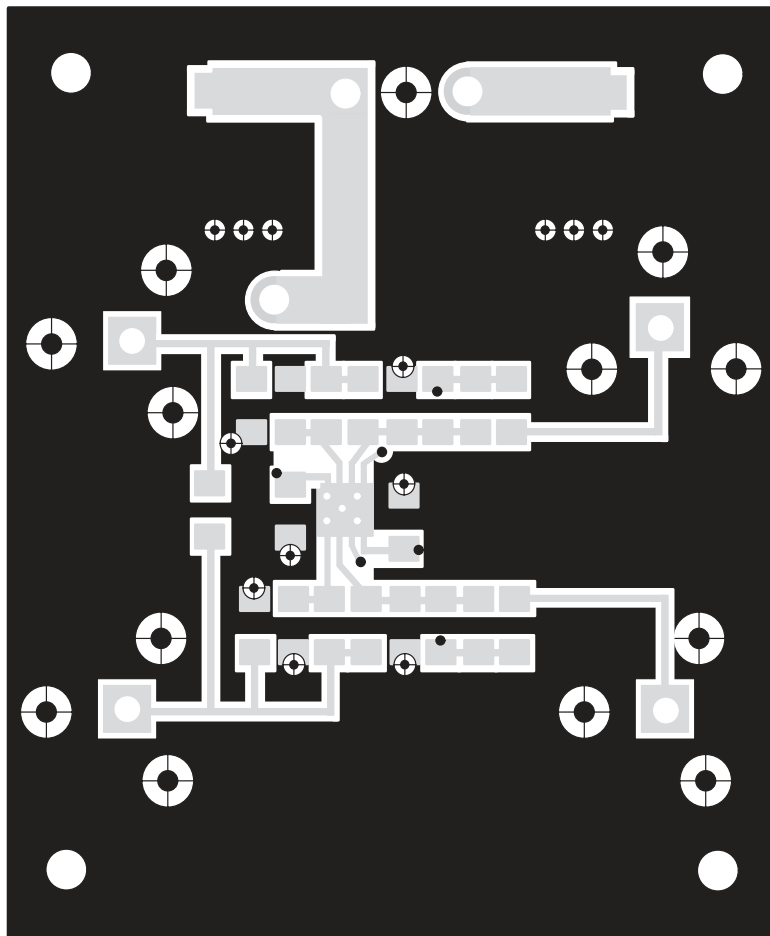

Figure 2–4. THS6072 EVM PC Board Layout: Back Side

