

ATLANTIC VERSION TERMINATOR INTERFACE ADAPTER	PART NUMBER	REVISION	DESCRIPTION	FEED TYPE	CONVERT TO	PART NUMBERS REQUIRED					
	2150351-1	A	FINE CRIMP HEIGHT ADJUST	MECHANICAL	PNEUMATIC FEED	2119950-1	2119792-2	-	2119641-1	-	2063440-1
	2150351-2	A	FINE CRIMP HEIGHT ADJUST	PNEUMATIC	SERVO LATCH PLATE	2119951-1	1901697-1	8-2150351-5	-	-	2168400-7 (QUANTITY 2)
					SMART APPLICATOR	2161326-1	-	8-2150351-4	-	-	-
					MECHANICAL FEED	2119949-1	2063961-1	5-18022-5	2119653-1	-	-
	2150351-5	A	FINE CRIMP HEIGHT ADJUST	SERVO LATCH PLATE ⁴	SERVO LATCH PLATE	2119951-1	1901697-1	8-2150351-5	-	-	2168400-7 (QUANTITY 2)
					SMART APPLICATOR	2161326-1	-	8-2150351-4	-	-	-
	2150351-6	A	NON-CRIMP HEIGHT ADJUST	SERVO LATCH PLATE ⁴	SERVO LATCH PLATE ¹²	2119949-1	2063961-1	5-18022-5	2119653-1	-	-
2150351-7	A	FINE CRIMP HEIGHT ADJUST	NONE	-	-	-	-	-	-	-	
7-2150351-7	A	CRIMP TOOLING KIT	-	-	-	-	-	-	-	-	

APPLICATOR DATA		
CRIMP	SIZE	TYPE
WIRE	2.00 mm [.079]	F
INSUL	2.60 mm [.102]	F
APPLICATOR INSTRUCTIONS 408-10390		

TERMINAL DATA: HELLA TERMINAL TE CRIMP SPECIFICATION			
TERMINAL NAME: CONTACT SPRING			
WIRE STRIP LENGTH		INSULATION DIAMETER RANGE	
3.75-4.52 mm [.148-.178 IN]		Ø1.20-2.00 mm [.047-.079 IN]	
TERMINAL APPLICATION SPECIFICATION	NONE	-	-
TERMINALS APPLIED			
TE TERMINAL	HELLA TERMINAL	TE TERMINAL	HELLA TERMINAL
2113356-1	151552-00		

WIRE SIZE	CRIMP HEIGHT mm [INCH]	CRIMP HEIGHT REFERENCE SETTING
1.00mm2	1.40 +/- 0.05 [.055 +/- .002]	8.2
0.75mm2	1.30 +/- 0.05 [.051 +/- .002]	9.2

- ¹ RECOMMENDED SPARE PARTS
- ² GREASE BEARING SURFACES LIGHTLY
- 3. LUBRICATE DAILY PER THE APPLICATOR INSTRUCTION SHEET SUPPLIED WITH THE APPLICATOR.
- ⁴ APPLICATOR SPECIFIC DATA TO BE ENTERED INTO BLANK MEMORY CHIP AT ASSEMBLY. SEE BELOW FOR PART NUMBER:
 MECHANICAL FEED WITH "SMART APPLICATOR" CONVERSION: 8-2150351-4
 PNEUMATIC FEED WITH "SMART APPLICATOR" CONVERSION: 8-2150351-4
 SERVO FEED WITH "FINE CRIMP HEIGHT ADJUST": 8-2150351-5
 SERVO FEED WITH "NON-CRIMP HEIGHT ADJUST": 8-2150351-6
- 5. ADJUSTMENT OF THE STRIPPER MAY BE REQUIRED WHEN MOVING THE APPLICATOR BETWEEN BENCH AND LEADMAKER APPLICATIONS.
- ⁶ APPLY PART NUMBER 1-23419-5 LOCTITE TO THREADS OF ITEMS 62 & 242. FOR -6 ONLY APPLY PART NUMBER 1-23419-5 LOCTITE TO THREADS OF ITEMS 37 & 242.
- ⁷ GREASE THREADS, GROOVE AND O-RING ON ITEMS 35 & 252.
- ⁸ MAGNET, ITEM 166 MUST BE ORIENTED CORRECTLY IN ORDER TO PROPERLY ACTUATE THE COUNTER.
- ⁹ CRIMP HEIGHT REFERENCE SETTING WAS THE SETTING USED WHEN THE APPLICATOR WAS QUALIFIED AT THE FACTORY. ADJUSTMENT MAY BE NECESSARY WHEN RUNNING APPLICATOR IN THE FIELD.
- ¹⁰ SPARE FEED CAM STORAGE LOCATION REFER TO INSTRUCTION SHEET FOR ADDITIONAL INFORMATION.
- ¹¹ THE RECOMMENDED SET-UP FOR END FEED APPLICATORS IS POST-FEED WITH ITEM 2119653-1. THE APPLICATOR CAN BE CONFIGURED FOR PRE-FEED WITH ITEM 2119652-1 BUT MAY ENCOUNTER PROBLEMS WITH SOME APPLICATIONS. FEED ISSUES OR TERMINAL JAMMING MAY OCCUR IN THE PRE-FEED CONFIGURATION.
- ¹² WHEN ASSEMBLING -6 NON-CRIMP HEIGHT ADJUST APPLICATOR USE SHIM PACK 2119957-2 TO ALIGN APPLICATOR'S MAXIMUM WIRE CRIMP HEIGHT AT NORMAL TERMINATOR SHUT HEIGHT

***WARNING**
 ON INSTALLATION, SET WIRE DISC, ITEM 40 TO LARGEST WIRE SIZE SETTING. USE OF SETTINGS BELOW MINIMUM REQUIRED CRIMP HEIGHT SETTING WILL CAUSE DAMAGE TO CRIMP TOOLING.

ATLANTIC VERSION
 Shown on sheets 1 of 4 & 2 of 4
 (Pacific version shown on sheets 3 of 4 & 4 of 4)

SET UP GAUGE	LOC	DIST	REVISIONS			
2119599-2	A	66	REV	DATE	BY	APPV
			A	RELEASED	20SEP2013	RK GB

REV	DATE	BY	APPV	DESCRIPTION	DATE	OWN	APPV		
-	-	1	-	-	-	2119957-2	APPLICATOR SHIM PACK	260	
-	-	1	-	1	1	8-21084-0	O-RING, .676 ID, .070 DIA. MAT.	252	
-	-	-	-	1	-	2119640-1	PUSH ROD, AIR FEED	250	
-	-	-	-	1	-	2079988-1	BUSHING, LCH5-12, MISUMI	249	
-	-	-	-	1	-	2119641-1	FEED CAM, AIR FEED	248	
-	-	1	-	1	1	2119798-1	DETENT PIN	247	
-	-	1	-	1	1	1-22279-3	SPRING, COMPRESSION	246	
-	-	1	-	-	-	2119759-1	RAM, AMP STYLE, END FEED, NON-ADJUST	245	
-	-	1	1	1	1	2119082-9	CAM, SNAIL, INSULATION ADJUSTMENT	244	
-	-	1	1	1	1	2079764-1	WASHER, WAVE SPRING, CREST-TO-CREST	243	
-	-	1	1	1	1	2119083-1	RETAINER, INSULATION DIAL	242	
-	-	2	2	-	-	2168400-7	SHCS, LOW HEAD, RoHS, M5 X 10	240	
-	-	-	-	-	1	2119580-1	MECHANICAL FEED ASSEMBLY	239	
-	-	-	-	-	1	2063440-1	AIR FEED MODULE	238	
-	-	1	1	-	-	2119740-2	TAG, IDENTIFICATION	213	
-	-	REFREF	-	-	-	1901697-1	FEED FINGER ASSEMBLY, EF	183	
-	-	-	-	2	-	21045-3	RING, RETAIN, EXTERN, 3/16 CRESCENT	172	
-	-	1	1	1	1	994969-1	MAGNET, RARE EARTH HIGH ENERGY	166	
-	-	REFREFREFREFREFREF	-	-	-	994970-2	COUNTER, MAGNETIC	164	
-	-	-	-	-	1	240638-1	SPRING, FEED FINGER	163	
-	-	-	-	-	1	3-23627-7	PIN, RETAIN, GRVD, 3/16 X .854	137	
-	-	REFREF	-	-	-	SEE NOTE 4	MEMORY CHIP, PROGRAMMED	135	
-	-	1	1	-	-	1633743-1	SERVO FEED LATCH ASM	133	
-	-	1	1	1	1	455888-4	SPACER, CRIMPER	82	
-	-	1	1	1	1	2119956-2	DOCUMENTATION PACKAGE	71	
-	-	2	2	2	2	2-18032-2	SCR, SET, FLT POINT M3 X 10.0	70	
-	-	1	-	-	1	2119740-1	TAG, IDENTIFICATION	67	
-	-	2	2	2	2	2168078-1	SCREW, DRIVE, RH, RoHS, 2 x .188	66	
-	-	1	-	1	1	2119793-1	LIMITER, ADJUSTMENT BOLT	63	
-	-	3	-	3	3	992763-5	SCR, SET, SOC, CONE POINT, M3 x 4.0	62	
-	-	1	1	1	1	2079383-4	SCR, BHSC, RoHS (M4 X 8)	60	
-	-	-	-	-	1	5-18022-5	SCR, HEX HD CAP, M4 X 6.0	59	
-	-	-	-	-	1	2063961-1	FEED FINGER	58	
-	-	4	4	4	4	2168400-4	SHCS, LOW HEAD, RoHS, M4 X 8	57	
-	-	2	2	2	2	1-2168083-0	SCR, SKT HD CAP, RoHS, M4 X 10	56	
-	-	2	2	2	2	5018030-2	NUT, HEX, REG, RoHS, M4	55	
-	-	2	2	2	2	5018030-1	NUT, HEX, REG, RoHS, M3	54	
-	-	2	2	2	2	986965-8	NUT, LOCK, HEX, TORQUE (M4)	53	
-	-	-	-	-	1	2119792-2	PAWL, EF, AIR	51	
-	-	-	-	-	1	2	18023-9	SCR, SKT HD CAP M4 X 6.0	49
-	-	-	-	-	1	2119652-1	FEED CAM, PRE FEED	48	
-	-	-	-	-	1	2119653-1	FEED CAM, POST FEED	47	
-	-	1	1	1	1	2119655-5	APPLICATOR BASIC ASSEMBLY, EF	46	
-	-	1	-	1	1	2119369-1	RAM, AMP STYLE, END FEED	44	
-	-	1	1	1	1	2079383-7	SCR, BHSC, RoHS (M8 X 25)	41	
-	-	1	-	1	1	2119645-1	DISC, NUMBERED FA WIRE ADJUSTMENT	40	
-	-	1	-	1	1	2119957-1	APPLICATOR SHIM PACK	39	
-	-	1	1	1	1	1-2119644-2	RAM WASHER, PRECISION	38	
-	-	1	1	1	1	2119085-1	FA HEAD, ATLANTIC STYLE	37	
-	-	1	-	1	1	2119092-1	BOLT, ADJUSTMENT	35	
-	-	8	8	8	8	1-18028-2	WASHER, FLAT, REG M4	33	
-	-	2	2	2	2	2168083-9	SCR, SKT HD CAP, RoHS, M4 X 20	31	
-	-	2	2	2	2	1-2168083-0	SCR, SKT HD CAP, RoHS, M4 X 10	29	
-	-	1	1	1	1	240639-1	STRIPPER (MACHINING)	27	
-	-	2	2	2	2	1320906-1	STUD, THREADED	25	
-	-	1	1	1	1	2-1752371-6	PLATE, STRIP GUIDE	24	
-	-	2	2	2	2	2-22281-3	SPRING, COMPRESSION	22	
-	-	1	1	1	1	1752373-4	DRAG	20	
-	-	1	1	1	1	1901259-4	GUIDE, LOWER STRIP	19	
-	-	1	1	1	1	7-1901695-0	STRIP GUIDE, FRONT	18	
-	-	4	4	4	4	1-2079383-1	SCR, BHSC, RoHS (M6 X 12)	17	
-	-	1	1	1	1	2-240641-8	SPACER	16	
-	-	1	1	1	1	2-240644-3	PLATE, REAR SHEAR	11	
-	-	2	2	2	2	2-240645-5	SPACER, SHEAR PLATE	10	
-	-	1	1	1	1	2-240644-2	PLATE, REAR SHEAR	9	
-	-	1	1	1	1	1803059-6	ANVIL, COMBINATION, END FEED	8	
-	-	1	1	1	1	1633797-2	BLADE, SLUG	7	
-	-	-	-	-	-	-	-	6	
-	-	1	1	1	1	240641-7	SPACER	5	
-	-	1	1	1	1	1-238009-7	BLOCK, FL CRIMPER SPACER	4	
-	-	1	1	1	1	1633961-8	CRIMPER, INSULATION F PREMIUM	3	
-	-	1	1	1	1	1-455888-1	SPACER, CRIMPER	2	
-	-	1	1	1	1	2-1633738-8	CRIMPER, WIRE	1	

DIMENSIONS:	TOLERANCES UNLESS OTHERWISE SPECIFIED:	DATE	BY	APPV	DESCRIPTION	ITEM NO
mm	0 PLC ±.5 1 PLC ±.5 2 PLC ±.5 3 PLC ±.5 4 PLC ±.5 ANGLES ±.0001	15AUG2013	R. O. WILSON	21AUG2013	TE Connectivity Harrisburg, PA 17105-3608	
			K. J. STARK	22AUG2013	Ocean End Feed Applicator	
			T. L. ELBIN			
MATERIAL:	FINISH:	WEIGHT:	SCALE:	1:1	SHEET 1 OF 4	REV A

LOC	DIST	REV	DATE	BY	APPV
A	66				
		REVISIONS			
		DESCRIPTION	DATE	BY	APPV
		SEE SHEET 1			

FEED TYPE MECHANICAL

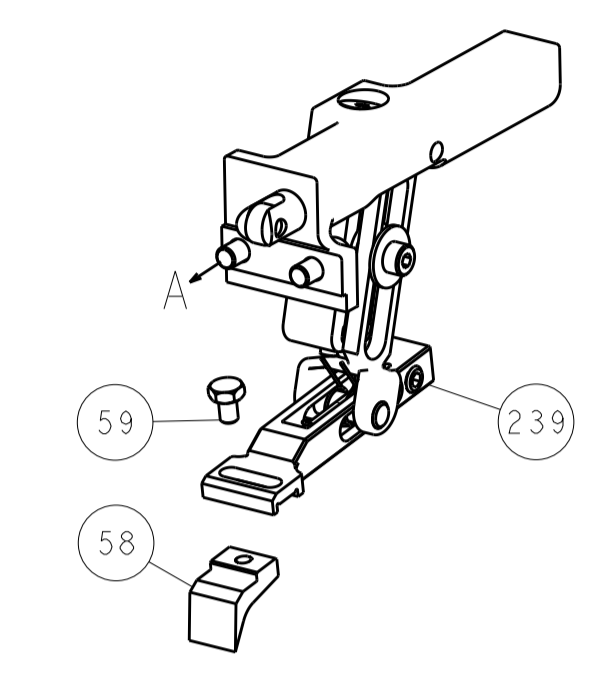

PNEUMATIC

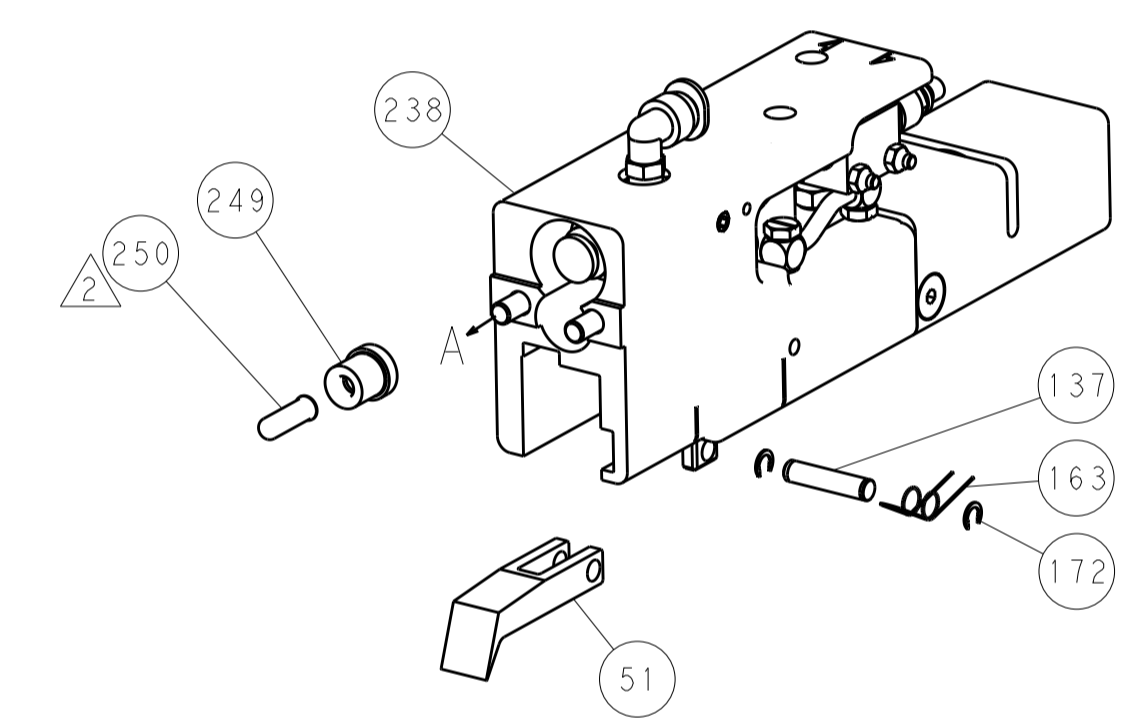

SERVO LATCH PLATE

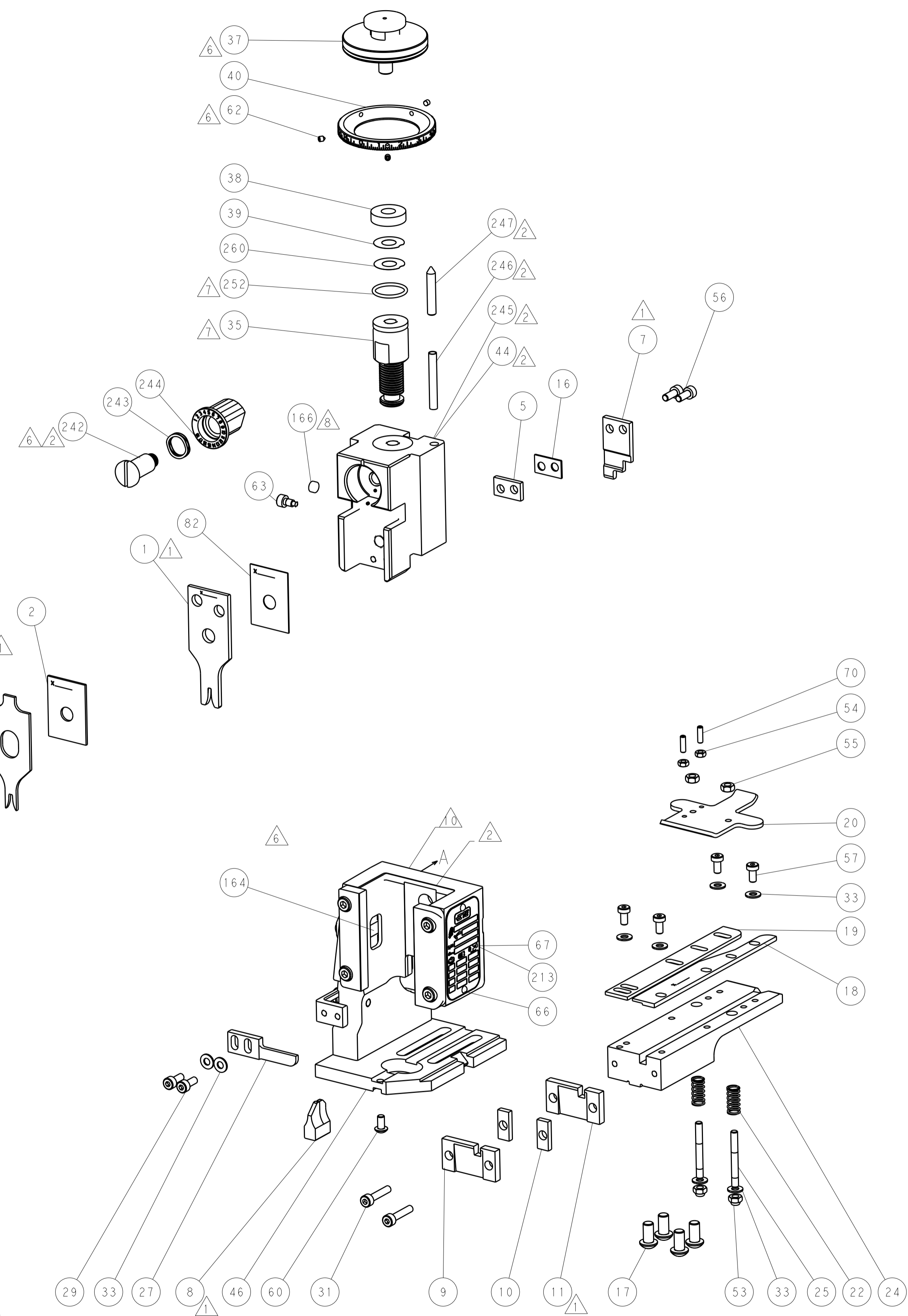
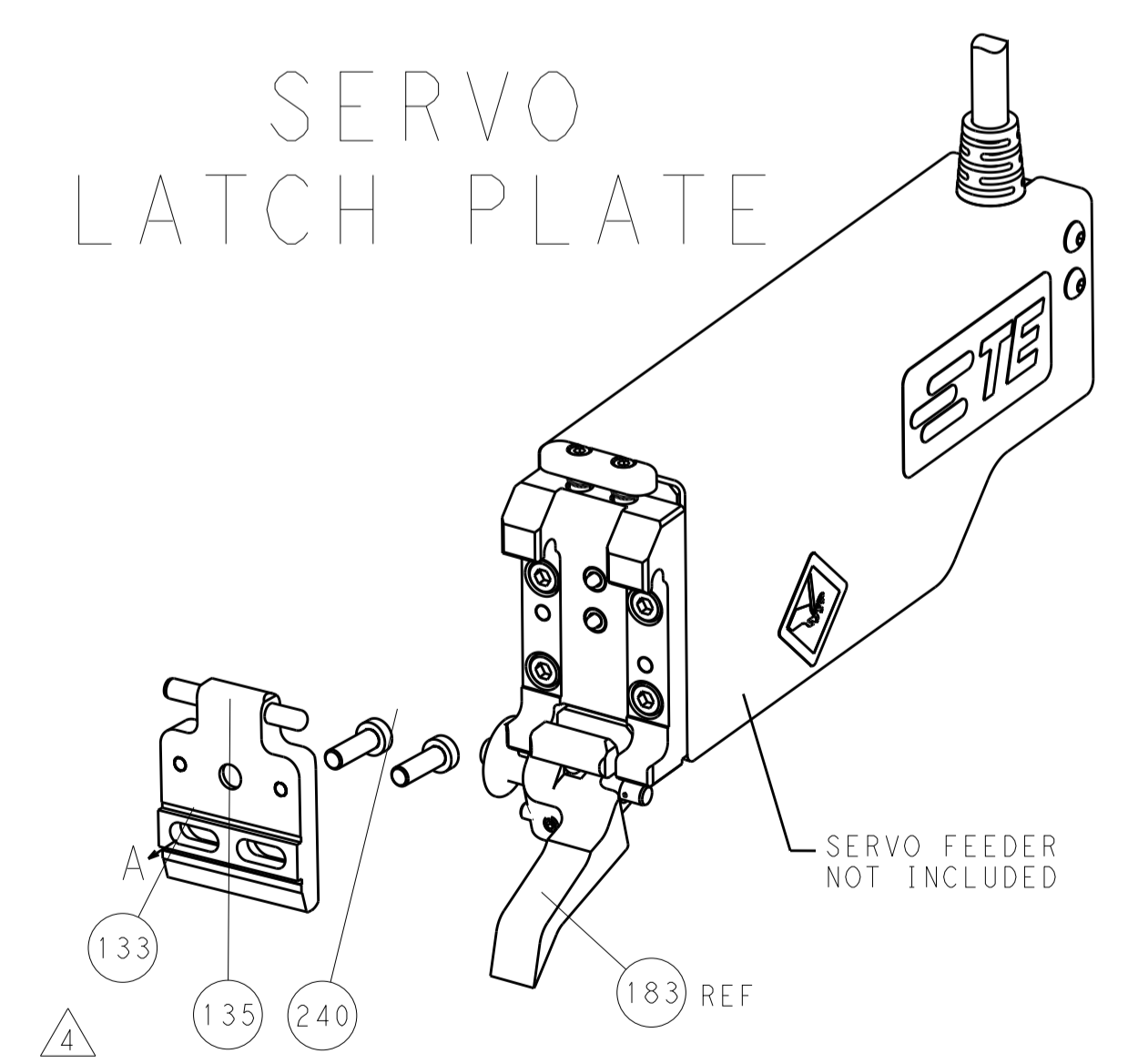

CAM POSITIONS

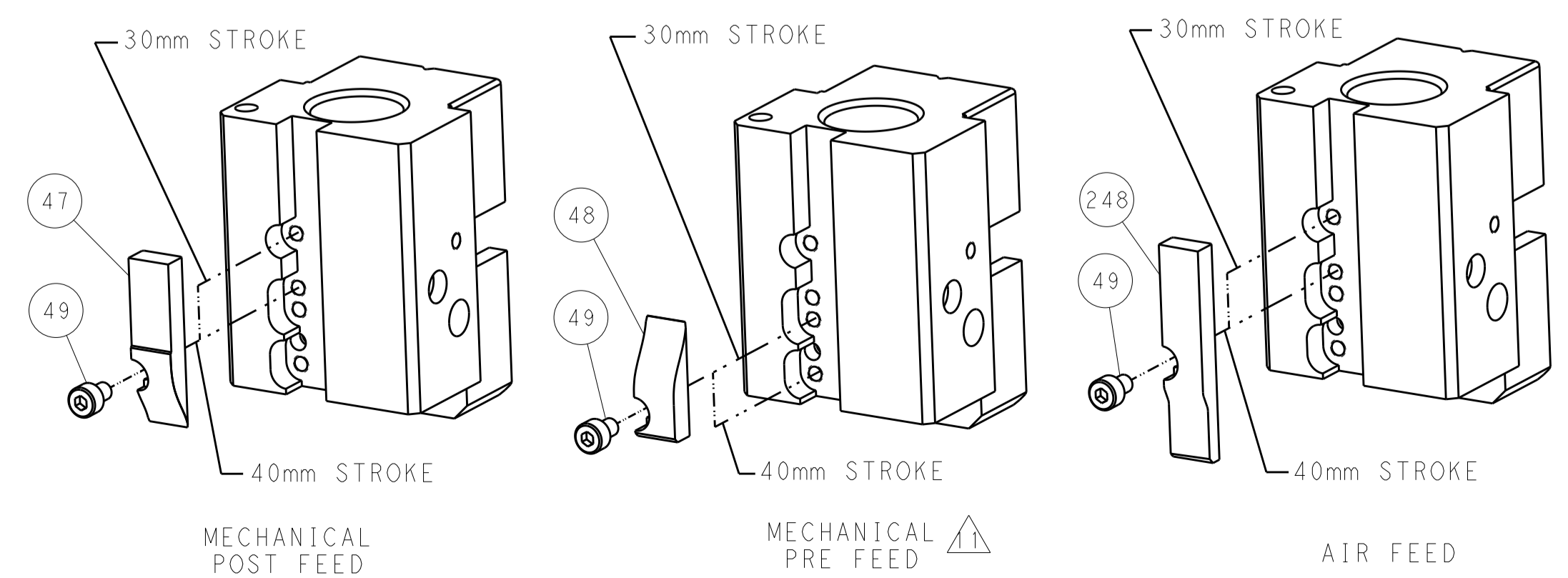

ATLANTIC VERSION
 Shown on sheets 1 of 4 & 2 of 4
 (Pacific version shown on sheets 3 of 4 & 4 of 4)

DIMENSIONS:		TOLERANCES UNLESS OTHERWISE SPECIFIED:		DWG: R. Q. WILSON 15AUG2013		TE Connectivity	
mm		0 PLC ±0.5		CHK: K. J. STAKEM 21AUG2013		Harrisburg, PA 17105-3608	
Ø		1 PLC ±0.13		APPV: T. L. ELBIN 22AUG2013		NAME: Ocean End Feed Applicator	
H		2 PLC ±0.013		PRODUCT SPEC:		SIZE: CAGE CODE: DRAWING NO:	
L		3 PLC ±0.013		APPLICATION SPEC:		RESTRICTED TO:	
R		4 PLC ±0.001		WEIGHT:		A1 00779 ©=2150351	
ANGLES		FINISH:		Customer Accessible Production Drawing		SCALE: 1:1 SHEET 2 OF 4 REV A	

PACIFIC VERSION TERMINATOR INTERFACE ADAPTER	PART NUMBER	REVISION	DESCRIPTION	FEED TYPE	APPLICATOR STYLE CONVERSION CHART						
					CONVERT TO	PART NUMBERS REQUIRED					
	2-2150351-1	A	FINE CRIMP HEIGHT ADJUST	MECHANICAL	PNEUMATIC FEED	2119950-1	2119792-2	-	2119641-2	-	2063440-1
					SERVO LATCH PLATE	2119951-1	1901697-1	8-2150351-5	-	-	2168400-7 (QUANTITY 2)
					SMART APPLICATOR	2161326-1	-	8-2150351-4	-	-	-
	2-2150351-2	A	FINE CRIMP HEIGHT ADJUST	PNEUMATIC	MECHANICAL FEED	2119949-1	2063961-1	5-18022-5	2119653-2	-	-
					SERVO LATCH PLATE	2119951-1	1901697-1	8-2150351-5	-	-	2168400-7 (QUANTITY 2)
					SMART APPLICATOR	2161326-1	-	8-2150351-4	-	-	-
	2-2150351-5	A	FINE CRIMP HEIGHT ADJUST	SERVO LATCH PLATE	MECHANICAL FEED	2119949-1	2063961-1	5-18022-5	2119653-2	-	-
					PNEUMATIC FEED	2119950-1	2119792-2	-	2119641-2	-	2063440-1
	2-2150351-7	A	FINE CRIMP HEIGHT ADJUST	NONE	-	-	-	-	-	-	-
	7-2150351-7	A	CRIMP TOOLING KIT	-	-	-	-	-	-	-	-

APPLICATOR DATA		
CRIMP	SIZE	TYPE
WIRE	2.00 mm [.079]	F
INSUL	2.60 mm [.102]	F
APPLICATOR INSTRUCTIONS 408-10390		

TERMINAL DATA: HELLA TERMINAL TE CRIMP SPECIFICATION			
TERMINAL NAME: CONTACT SPRING			
WIRE STRIP LENGTH		INSULATION DIAMETER RANGE	
3.75-4.52 mm [.148-.178 IN]		Ø1.20-2.00 mm [.047-.079 IN]	
TERMINAL APPLICATION SPECIFICATION	NONE	-	-
TERMINALS APPLIED			
TE TERMINAL	HELLA TERMINAL	TE TERMINAL	HELLA TERMINAL
2113356-1	151552-00		

WIRE SIZE	CRIMP HEIGHT mm [INCH]	CRIMP HEIGHT REFERENCE SETTING
1.00mm2	1.40 +/- 0.000 [.055 +/- .000]	8.2
0.75mm2	1.30 +/- 0.000 [.051 +/- .000]	9.2

- RECOMMENDED SPARE PARTS
- GREASE BEARING SURFACES LIGHTLY
- 3. LUBRICATE DAILY PER THE APPLICATOR INSTRUCTION SHEET SUPPLIED WITH THE APPLICATOR.
- APPLICATOR SPECIFIC DATA TO BE ENTERED INTO BLANK MEMORY CHIP AT ASSEMBLY. SEE BELOW FOR PART NUMBER:
 MECHANICAL FEED WITH "SMART APPLICATOR" CONVERSION: 8-2150351-4
 PNEUMATIC FEED WITH "SMART APPLICATOR" CONVERSION: 8-2150351-4
 SERVO FEED WITH "FINE CRIMP HEIGHT ADJUST": 8-2150351-5
- 5. ADJUSTMENT OF THE STRIPPER MAY BE REQUIRED WHEN MOVING THE APPLICATOR BETWEEN BENCH AND LEADMAKER APPLICATIONS.
- APPLY PART NUMBER 1-23419-5 LOCTITE TO THREADS OF ITEMS 62 & 242.
- GREASE THREADS, GROOVE AND O-RING ON ITEMS 139 & 153.
- MAGNET, ITEM 166 MUST BE ORIENTED CORRECTLY IN ORDER TO PROPERLY ACTUATE THE COUNTER.
- CRIMP HEIGHT REFERENCE SETTING WAS THE SETTING USED WHEN THE APPLICATOR WAS QUALIFIED AT THE FACTORY. ADJUSTMENT MAY BE NECESSARY WHEN RUNNING APPLICATOR IN THE FIELD.
- SPARE FEED CAM STORAGE LOCATION REFER TO INSTRUCTION SHEET FOR ADDITIONAL INFORMATION.
- THE RECOMMENDED SET-UP FOR END FEED APPLICATORS IS POST-FEED WITH ITEM 2119653-1. THE APPLICATOR CAN BE CONFIGURED FOR PRE-FEED WITH ITEM 2119652-1 BUT MAY ENCOUNTER PROBLEMS WITH SOME APPLICATIONS. FEED ISSUES OR TERMINAL JAMMING MAY OCCUR IN THE PRE-FEED CONFIGURATION.

***WARNING**
 ON INSTALLATION, SET WIRE DISC, ITEM 40 TO LARGEST WIRE SIZE SETTING. USE OF SETTINGS BELOW MINIMUM REQUIRED CRIMP HEIGHT SETTING WILL CAUSE DAMAGE TO CRIMP TOOLING.

PACIFIC VERSION
 Shown on sheets 3 of 4 & 4 of 4
 (Atlantic version shown on sheets 1 of 4 & 2 of 4)

SET UP GAUGE	LOC	DIST	REVISIONS			
2119599-2	A	66	REV	DATE	BY	APPV
			-	SEE SHEET 1	-	-

-	1	1	1	1	2119782-1	FINE ADJUST HEAD ASM, PACIFIC STYLE	251
-	-	-	1	-	2119640-1	PUSH ROD, AIR FEED	250
-	-	-	1	-	2079988-1	BUSHING, LCH5-12, MISUMI	249
-	1	1	1	1	1-22279-3	SPRING, COMPRESSION	246
-	1	1	1	1	2119082-9	CAM, SNAIL, INSULATION ADJUSTMENT	244
-	1	1	1	1	2079764-1	WASHER, WAVE SPRING, CREST-TO-CREST	243
-	1	1	1	1	2119083-1	RETAINER, INSULATION DIAL	242
-	-	2	-	-	2168400-7	SHCS, LOW HEAD, RoHS, M5 X 10	240
-	-	-	-	1	2119580-1	MECHANICAL FEED ASSEMBLY	239
-	-	-	1	-	2063440-1	AIR FEED MODULE	238
-	-	1	-	-	2119740-2	TAG, IDENTIFICATION	213
-	4	4	4	4	2079383-9	SCR, BHSC, RoHS (M6 X 20)	186
-	-	REF	-	-	1901697-1	FEED FINGER ASSEMBLY, EF	183
-	-	-	2	-	21045-3	RING, RETAIN, EXTERN, 3/16 CRESCENT	172
-	1	1	1	1	994969-1	MAGNET, RARE EARTH HIGH ENERGY	166
-	REF	REF	REF	REF	994970-2	COUNTER, MAGNETIC	164
-	-	-	1	-	240638-1	SPRING, FEED FINGER	163
-	1	1	1	1	8-21084-1	O-RING, .801 ID, .070 DIA. MAT.	153
-	-	-	1	-	2119641-2	FEED CAM, AIR FEED	152
-	1	1	1	1	2119798-2	DETENT PIN	145
-	1	1	1	1	2079383-8	SCR, BHSC, RoHS (M4 X 16)	144
-	-	-	-	1	2119653-2	FEED CAM, POST FEED	142
-	1	1	1	1	2119655-6	APPLICATOR BASIC ASSEMBLY, EF	141
-	1	1	1	1	2119651-1	RAM, ASIAN STYLE, END FEED	140
-	1	1	1	1	2119092-2	BOLT, ADJUSTMENT	139
-	-	-	1	-	3-23627-7	PIN, RETAIN, GRVD, 3/16 X .854	137
-	-	REF	-	-	SEE NOTE 4	MEMORY CHIP, PROGRAMMED	135
-	-	1	-	-	1633743-1	SERVO FEED LATCH ASM	133
-	1	1	1	1	455888-4	SPACER, CRIMPER	82
-	1	1	1	1	2119956-2	DOCUMENTATION PACKAGE	71
-	2	2	2	2	2-18032-2	SCR, SET, FLT POINT M3 X 10.0	70
-	1	-	1	1	2119740-1	TAG, IDENTIFICATION	67
-	2	2	2	2	2168078-1	SCREW, DRIVE, RH, RoHS, 2 x .188	66
-	1	1	1	1	2119793-1	LIMITER, ADJUSTMENT BOLT	63
-	3	3	3	3	992763-5	SCR, SET, SOC, CONE POINT, M3 x 4.0	62
-	-	-	-	1	5-18022-5	SCR, HEX HD CAP, M4 X 6.0	59
-	-	-	-	1	2063961-1	FEED FINGER	58
-	4	4	4	4	2168400-4	SHCS, LOW HEAD, RoHS, M4 X 8	57
-	2	2	2	2	1-2168083-0	SCR, SKT HD CAP, RoHS, M4 X 10	56
-	2	2	2	2	5018030-2	NUT, HEX, REG, RoHS, M4	55
-	2	2	2	2	5018030-1	NUT, HEX, REG, RoHS, M3	54
-	2	2	2	2	986965-8	NUT, LOCK, HEX, TORQUE (M4)	53
-	-	-	1	-	2119792-2	PAWL, EF, AIR	51
-	-	-	1	2	18023-9	SCR, SKT HD CAP M4 X 6.0	49
-	-	-	-	1	2119652-1	FEED CAM, PRE FEED	48
-	1	1	1	1	2079383-7	SCR, BHSC, RoHS (M8 X 25)	41
-	1	1	1	1	2119645-1	DISC, NUMBERED FA WIRE ADJUSTMENT	40
-	1	1	1	1	2119957-1	APPLICATOR SHIM PACK	39
-	1	1	1	1	1-2119644-2	RAM WASHER, PRECISION	38
-	8	8	8	8	1-18028-2	WASHER, FLAT, REG M4	33
-	2	2	2	2	2168083-9	SCR, SKT HD CAP, RoHS, M4 X 20	31
-	2	2	2	2	1-2168083-0	SCR, SKT HD CAP, RoHS, M4 X 10	29
-	1	1	1	1	240639-1	STRIPPER (MACHINING)	27
-	2	2	2	2	1320906-1	STUD, THREADED	25
-	1	1	1	1	2-1752371-6	PLATE, STRIP GUIDE	24
-	2	2	2	2	2-22281-3	SPRING, COMPRESSION	22
-	1	1	1	1	1752373-4	DRAG	20
-	1	1	1	1	1901259-4	GUIDE, LOWER STRIP	19
-	1	1	1	1	7-1901695-0	STRIP GUIDE, FRONT	18
-	1	1	1	1	2-240641-8	SPACER	16
-	1	1	1	1	2-240644-3	PLATE, REAR SHEAR	11
-	2	2	2	2	2-240645-5	SPACER, SHEAR PLATE	10
-	1	1	1	1	2-240644-2	PLATE, REAR SHEAR	9
-	1	1	1	1	1803059-6	ANVIL, COMBINATION, END FEED	8
-	1	1	1	1	1633797-2	BLADE, SLUG	7
-	-	-	-	-	-	-	6
-	1	1	1	1	240641-7	SPACER	5
-	1	1	1	1	1-238009-7	BLOCK, FL CRIMPER SPACER	4
-	1	1	1	1	1633961-8	CRIMPER, INSULATION F PREMIUM	3
-	1	1	1	1	1-455888-1	SPACER, CRIMPER	2
-	1	1	1	1	2-1633738-8	CRIMPER, WIRE	1

DIMENSIONS:		TOLERANCES UNLESS OTHERWISE SPECIFIED:		DRAWN		CHECKED		APPROVED		DATE	
mm	0 PLC ±.5	1 PLC ±.3	2 PLC ±.13	3 PLC ±.013	4 PLC ±.0001	ANGLES ±.0001	FINISH	R. O. WILSON	15AUG2013	R. O. WILSON	21AUG2013
								K. J. STARKAM		K. J. STARKAM	
								T. L. ELBIN	22AUG2013	T. L. ELBIN	
MATERIAL:				FINISH:				WEIGHT:			
Customer Accessible Production Drawing				SCALE: 1:1				SHEET 3 OF 4			

LOC		DIST		REVISIONS			
A	66	P	LTM	DESCRIPTION	DATE	OWN	APVD
		-	-	SEE SHEET 1	-	-	-

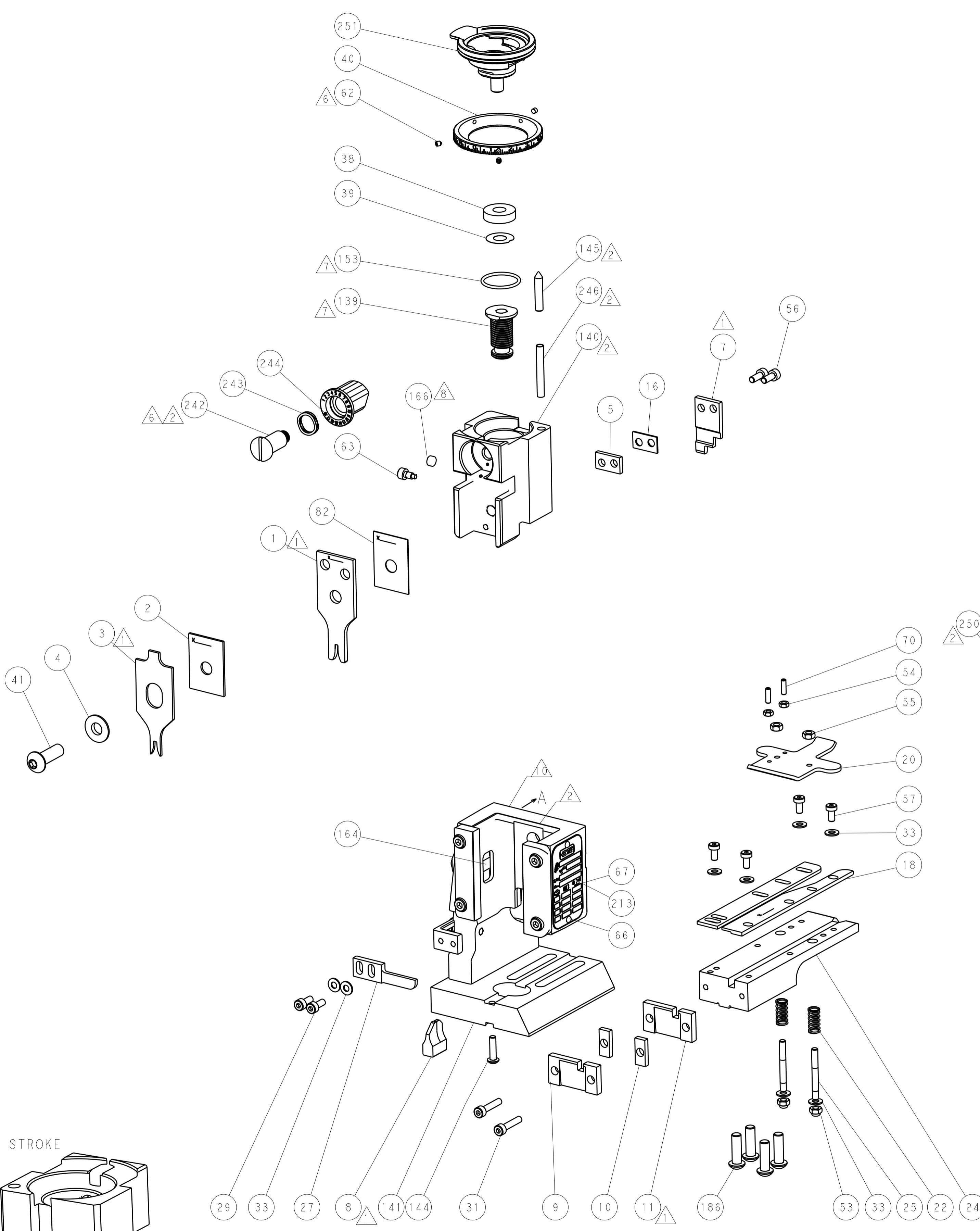

FEED TYPE
MECHANICAL

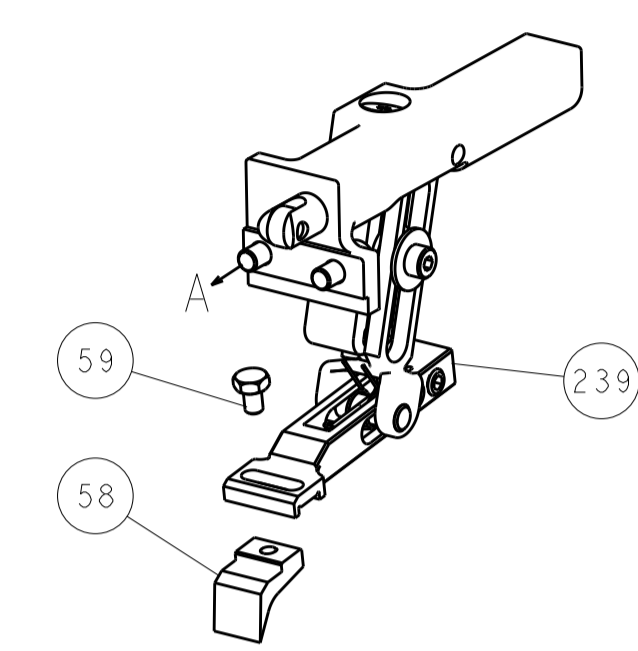

PNEUMATIC

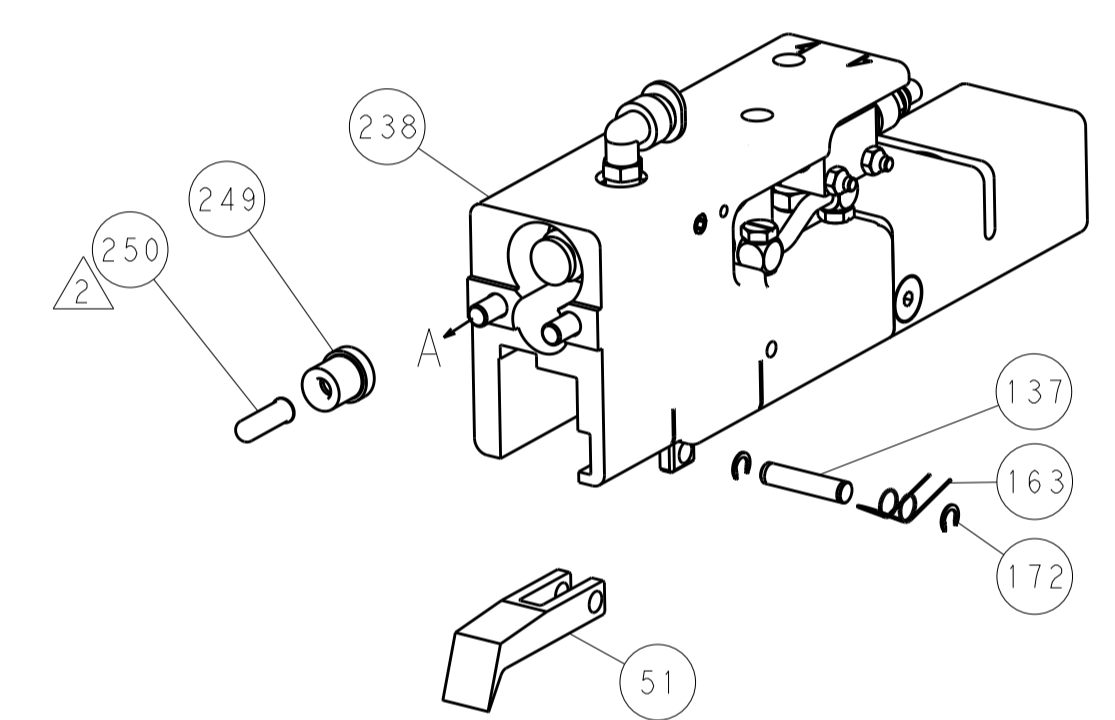

SERVO
LATCH PLATE

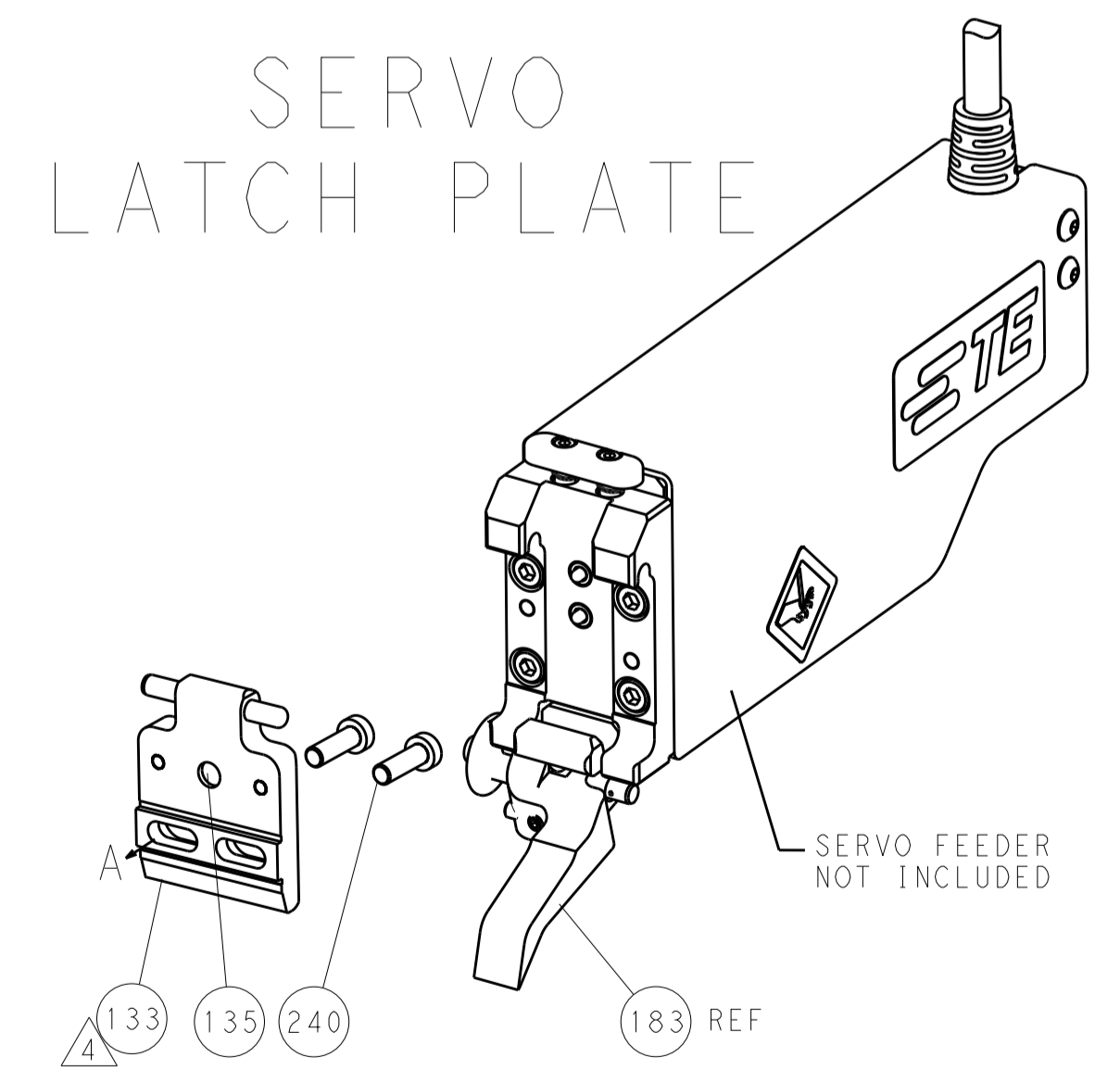

CAM POSITIONS

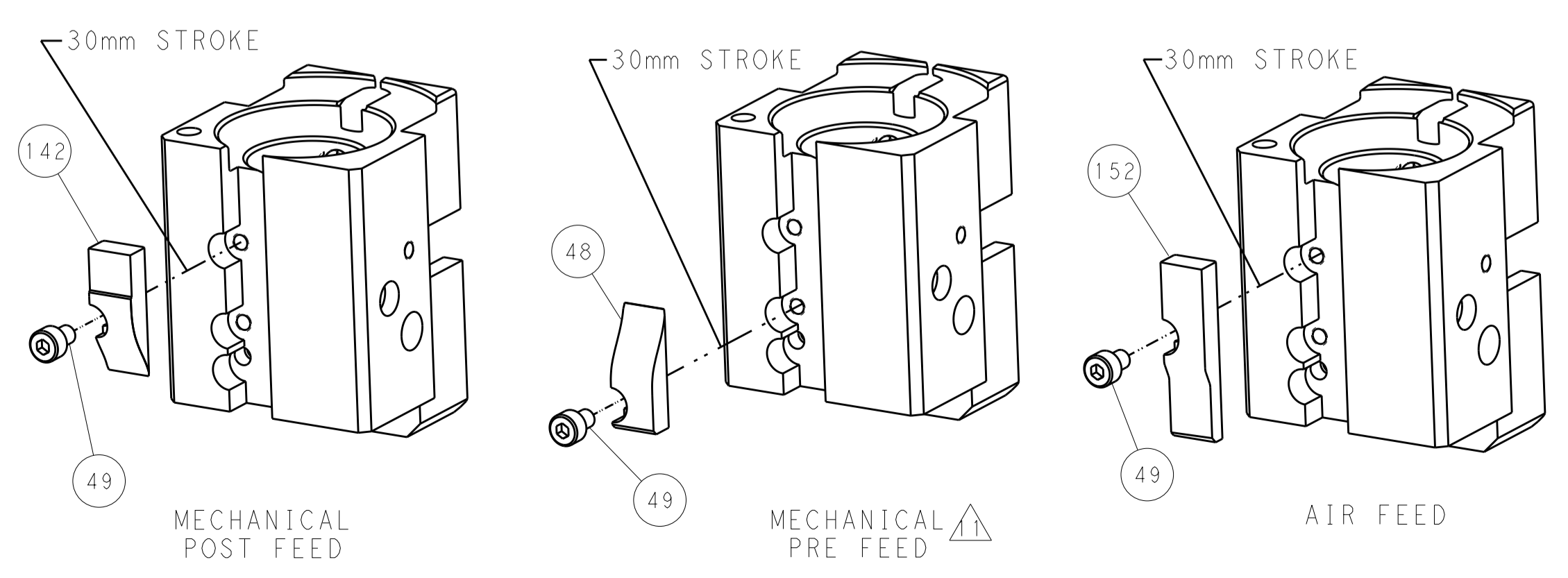

PACIFIC VERSION
 Shown on sheets 3 of 4 & 4 of 4
 (Atlantic version shown on sheets 1 of 4 & 2 of 4)

DIMENSIONS:		TOLERANCES UNLESS OTHERWISE SPECIFIED:		DWN R.O. WILSON 15AUG2013		TE Connectivity	
mm	0 PLC ±0.5	1 PLC ±0.5	2 PLC ±0.13	3 PLC ±0.13	CHK K.J. STAKEM 21AUG2013	Harrisburg, PA 17105-3608	
	4 PLC ±0.013	5 PLC ±0.001	ANGLES ±0.001	APVD T.L. ELBIN 22AUG2013	NAME		
MATERIAL:	FINISH:	WEIGHT:		Customer Accessible Production Drawing		RESTRICTED TO	
SCALE 1:1		SHEET 4 OF 4		REV A		Customer Accessible Production Drawing	