



ELECTRONICS, INC.
 44 FARRAND STREET
 BLOOMFIELD, NJ 07003
 (973) 748-5089
<http://www.nteinc.com>

NTE40106B & NTE40106BT Integrated Circuit CMOS, Hex Schmitt Trigger

Description:

The NTE40106B (14-Lead DIP) and NTE40106BT (SOIC-14) consist of six Schmitt Trigger circuits. Each circuit functions as an inverter with Schmitt Trigger action on the input. The trigger switches different points for positive-going and negative-going signals. The difference between the positive-going voltage (V_P) and the negative-going voltage (V_N) is defined as hysteresis voltage (V_H).

Features:

- Schmitt-Trigger with No External Components
- Hysteresis Voltage (Typ): 0.9V at $V_{DD} = 5V$, 2.3V at $V_{DD} = 10V$, 3.5V at $V_{DD} = 15V$
- Noise Immunity Greater Than 50%
- No Limit on Input Rise and Fall Times
- Standardized, Symmetrical Output Characteristics
- Maximum Input Current of $1\mu A$ at 18V over Full Package Temperature Range: 100nA at 18V and $+25^\circ C$
- Low V_{DD} to V_{SS} Current during Slow Input Ramp
- 5V, 10V, and 15V Parametric Ratings

Applications:

- Wave and Pulse Shapers
- High-Noise-Environment Systems
- Monostable Multivibrators
- Astable Multivibrators

Absolute Maximum Ratings:

DC Supply Voltage (Voltages Referenced to V_{SS}), V_{DD}	-0.5 to +20V
Input Voltage (All Inputs)	-0.5 to $V_{DD}+0.5V$
DC Input Current (Any One Input)	$\pm 10mA$
Power Dissipation (Per Package), P_D	
For $T_A = -55^\circ$ to $+100^\circ C$	500mW
For $T_A = +100^\circ$ to $+125^\circ C$	Derate Linearly at 12mW/ $^\circ C$ to 200mW
Device Dissipation (Per Output Transistor)	
For $T_A =$ Full package Temperature Range	100mW
Operating Temperature Range, T_A	-55° to $+125^\circ C$
Storage Temperature Range, T_{stg}	-65° to $+150^\circ C$
Lead Temperature (During Soldering, 10sec), T_L	$+265^\circ C$

Recommended Operating Conditions:

DC Supply Voltage (For $T_A =$ Full Package Temperature Range)	3 to 18V
--	----------

Static Electrical Characteristics:

Characteristic	Conditions			Limits at Indicated Temperature (°C)							Units	
	V _O (V)	V _{IN} (V)	V _{DD} (V)	-55°C	-40°C	+85°C	+125°C	+25°C				
								Min.	Typ.	Max.		
Quiescent Device Current, I _{DD} Max	-	0,5	5	1	1	30	30	-	0.02	1	μA	
	-	0,10	10	2	2	60	60	-	0.02	2	μA	
	-	0,15	15	4	4	120	120	-	0.02	4	μA	
	-	0,20	20	20	20	600	600	-	0.04	20	μA	
Positive Trigger Threshold Voltage, V _P Min.	-	-	5	2.2	2.2	2.2	2.2	2.2	2.9	-	V	
	-	-	10	4.6	4.6	4.6	4.6	4.6	5.9	-	V	
	-	-	15	6.8	6.8	6.8	6.8	6.8	8.8	-	V	
	V _P Max.	-	-	5	3.6	3.6	3.6	3.6	-	2.9	3.6	V
		-	-	10	7.1	7.1	7.1	7.1	-	5.9	7.1	V
-	-	15	10.8	10.8	10.8	10.8	-	8.8	10.8	V		
Negative Trigger Threshold Voltage, V _N Min.	-	-	5	0.9	0.9	0.9	0.9	0.9	1.9	-	V	
	-	-	10	2.5	2.5	2.5	2.5	2.5	3.9	-	V	
	-	-	15	4.0	4.0	4.0	4.0	4.0	5.8	-	V	
	V _N Max.	-	-	5	2.8	2.8	2.8	2.8	-	1.9	2.8	V
		-	-	10	5.2	5.2	5.2	5.2	-	3.9	5.2	V
-	-	15	7.4	7.4	7.4	7.4	-	5.8	7.4	V		
Hysteresis Voltage, V _H Min.	-	-	5	0.3	0.3	0.3	0.3	0.3	0.9	-	V	
	-	-	10	1.2	1.2	1.2	1.2	1.2	2.3	-	V	
	-	-	15	1.6	1.6	1.6	1.6	1.6	3.5	-	V	
	V _H Max.	-	-	5	1.6	1.6	1.6	1.6	-	0.9	1.6	V
		-	-	10	3.4	3.4	3.4	3.4	-	2.3	3.4	V
-	-	15	5.0	5.0	5.0	5.0	-	3.5	5.0	V		
Output Low (Sink) Current I _{OL} Min.	0.4	0,5	5	0.64	0.61	0.42	0.36	0.51	1.0	-	mA	
	0.5	0,10	10	1.6	1.5	1.1	0.9	1.3	2.6	-	mA	
	1.5	0,15	15	4.2	4.0	2.8	2.4	3.4	6.8	-	mA	
Output High (Source) Current I _{OH} Min.	4.6	0,5	5	-0.64	-0.61	-0.42	-0.36	-0.51	-1.0	-	mA	
	2.5	0,5	5	-2.0	-1.8	-1.3	-1.15	-1.6	-3.2	-	mA	
	9.5	0,10	10	-1.6	-1.5	-1.1	-0.9	-1.3	-2.6	-	mA	
	13.5	0,15	15	-4.2	-4.0	-2.8	-2.4	-3.4	-6.8	-	mA	
Output Voltage Low-Level V _{OL} Max.	-	5	5	0.05				-	0	0.05	V	
	-	10	10	0.05				-	0	0.05	V	
	-	15	15	0.05				-	0	0.05	V	
Output Voltage High-Level V _{OH} Min.	-	5	5	4.95				4.95	5	-	V	
	-	10	10	9.95				9.95	10	-	V	
	-	15	15	14.95				14.95	15	-	V	
Input Current, I _{IN} Max.	-	0,18	18	±0.1	±0.1	±1.0	±1.0	-	±10 ⁻⁵	±0.1	μA	

Dynamic Electrical Characteristics: ($T_A = +25^\circ\text{C}$, $C_L = 50\text{pF}$, $R_L = 200\text{k}\Omega$, t_r and $t_f = 20\text{ns}$ unless otherwise specified)

Parameter	Symbol	Test Conditions	Min	Typ	Max	Unit
Propagation Delay Time from	t_{PHL} or t_{PLH}	$V_{DD} = 5\text{V}$	–	140	280	ns
		$V_{DD} = 10\text{V}$	–	70	140	ns
		$V_{DD} = 15\text{V}$	–	60	120	ns
Transition Time	t_{THL} or t_{TLH}	$V_{DD} = 5\text{V}$	–	100	200	ns
		$V_{DD} = 10\text{V}$	–	50	100	ns
		$V_{DD} = 15\text{V}$	–	40	80	ns
Input Capacitance	C_{IN}	Any Input	–	5.0	7.5	pF

Functional Diagram

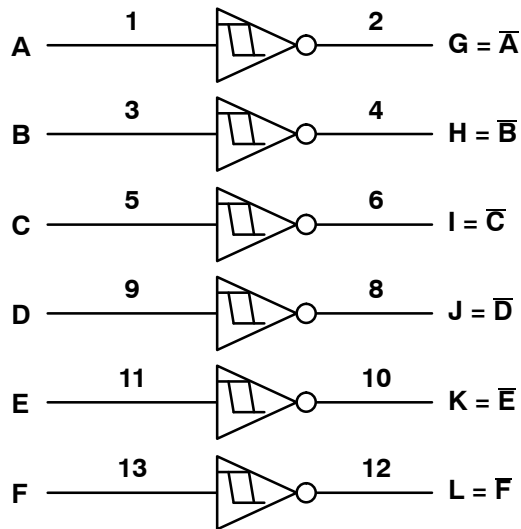

$V_{DD} = \text{Pin14}$
 $V_{SS} = \text{Pin7}$

Pin Connection Diagram

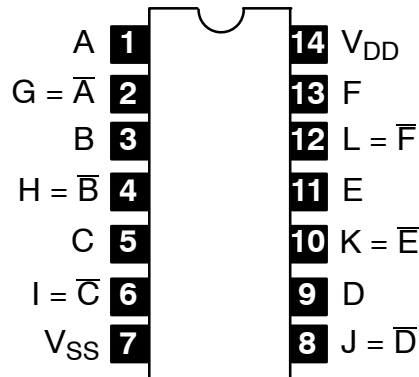

NTE40106B

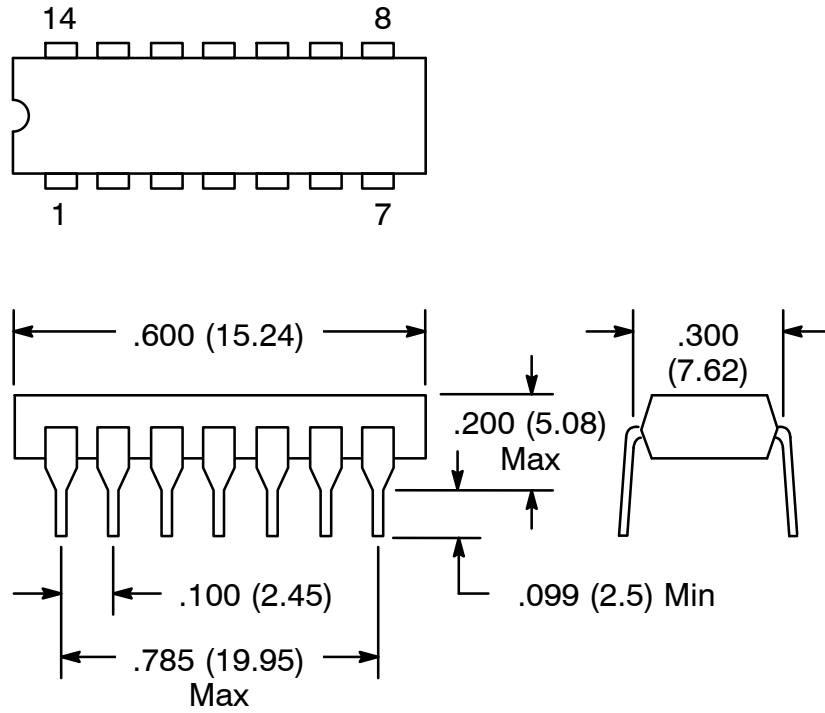

NTE40106BT

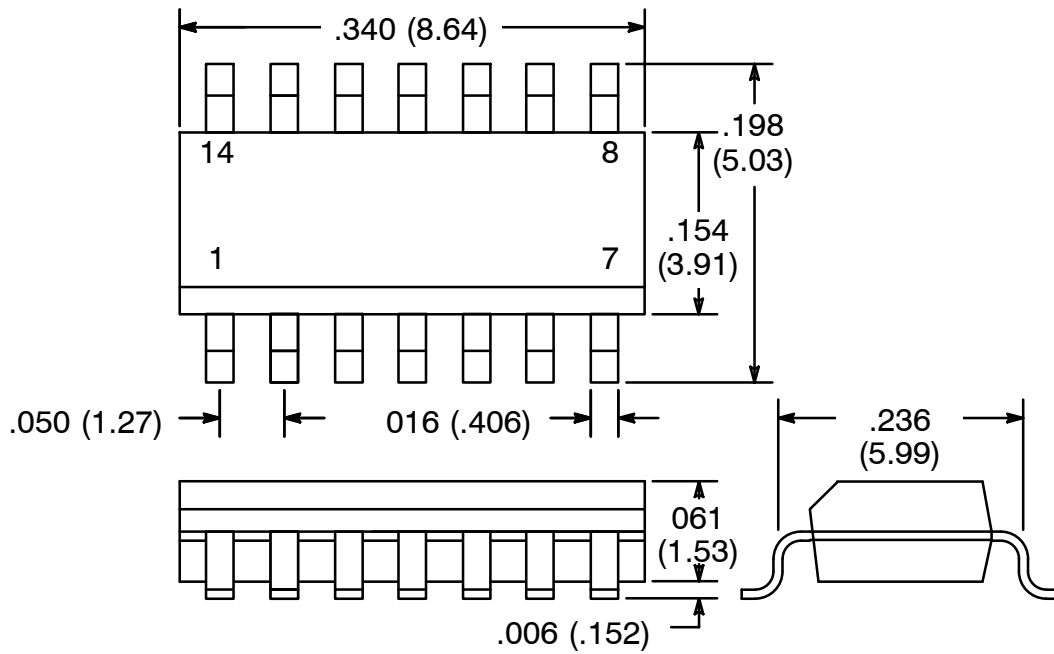

NOTE: Pin1 on Beveled Edge