

LOC		DIST		REVISIONS			
P	LTR	DATE	DESCRIPTION	DATE	DMN	APVD	
E		09OCT2010	REVISED ECO-10-021160		RC	CW	
F		13DEC11	ECO-11-024491		SY	MQW	

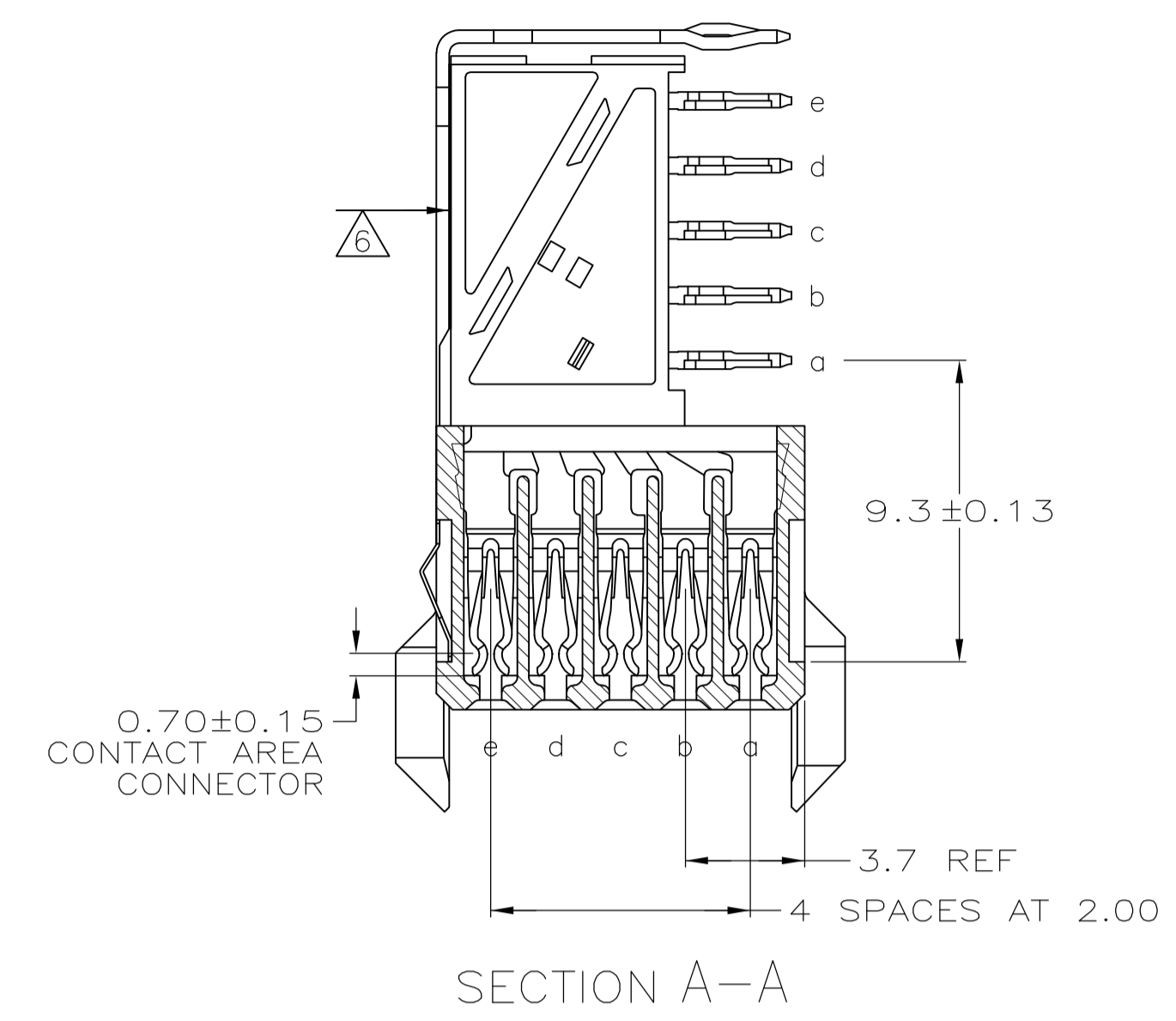

- 1 MATERIAL:
CONTACT: PHOSPHOR BRONZE.
HOUSING: GLASS-FILLED POLYESTER.
- 2 GENERAL PLATING SPECIFICATION: UNDERPLATING (ENTIRE CONTACT): 1.27µm MIN NICKEL AND ACTION PIN: 0.5µm MIN TIN LEAD. FOR PLATING OF MATING SURFACES SEE APPLICABLE SPECIFICATION REFERENCE FOR EACH DASH NUMBER.
- 3 CONFORMS TO ALL TESTING ACCORDING TO IEC 61076-4-101 PERFORMANCE LEVEL 2.
- 4 PLATED THROUGH HOLES AT 2mm x 2mm GRID.
- 5 ROW "f" 13 PLATED THROUGH HOLES FOR UPPER SHIELD.
- 6 SHIELD MOUNTED ON CONNECTOR WITH DOUBLE SIDED ADHESIVE TAPE.
- 7 CONNECTOR MARKED WITH PART NUMBER AND DATE CODE.
- 8 0.76 µm GOLD PLATING ON MATING SURFACES.
- 9 CONFORMS TO ALL TESTING ACCORDING TO IEC 61076-4-101 PERFORMANCE LEVEL 1.

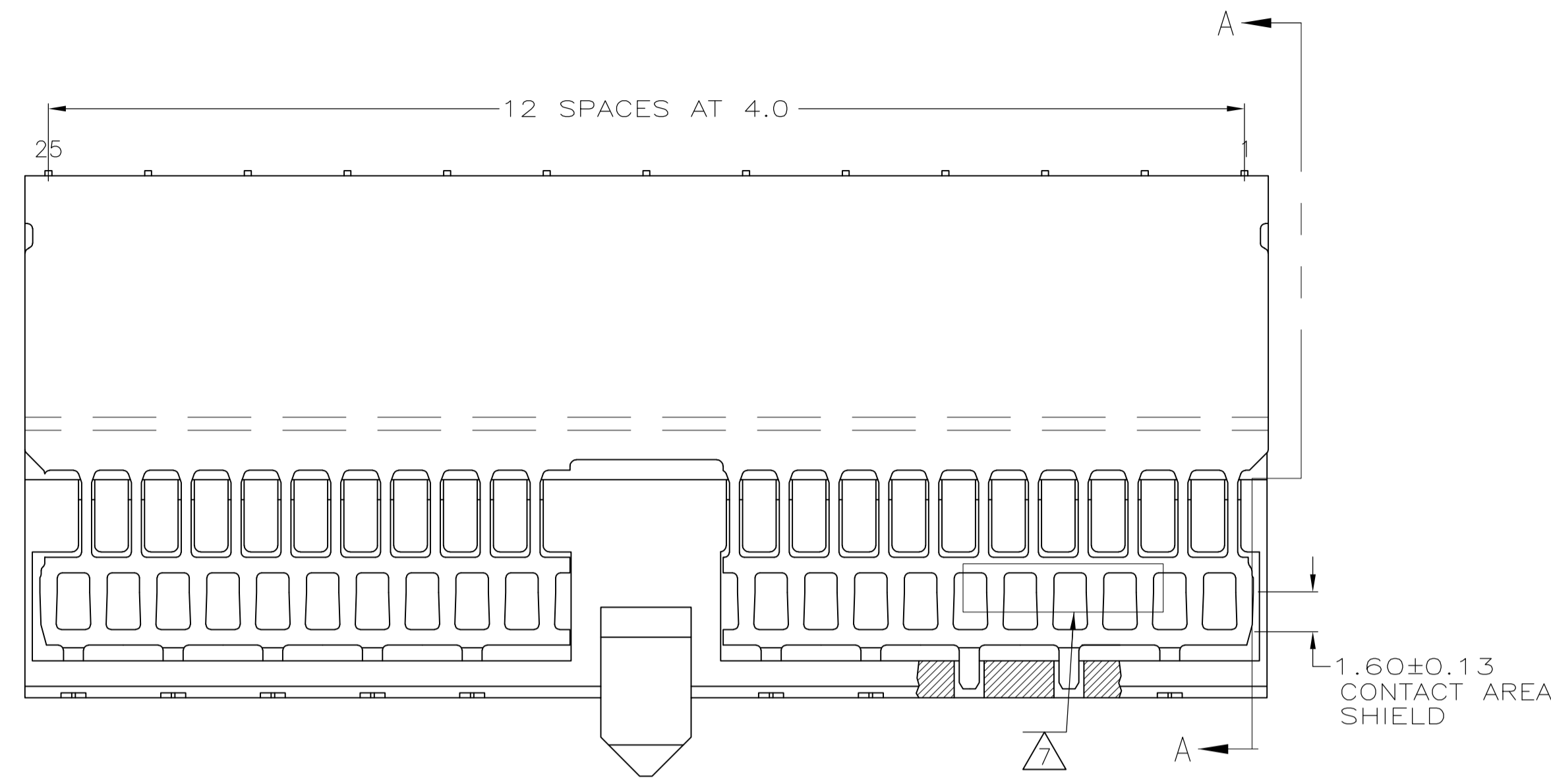
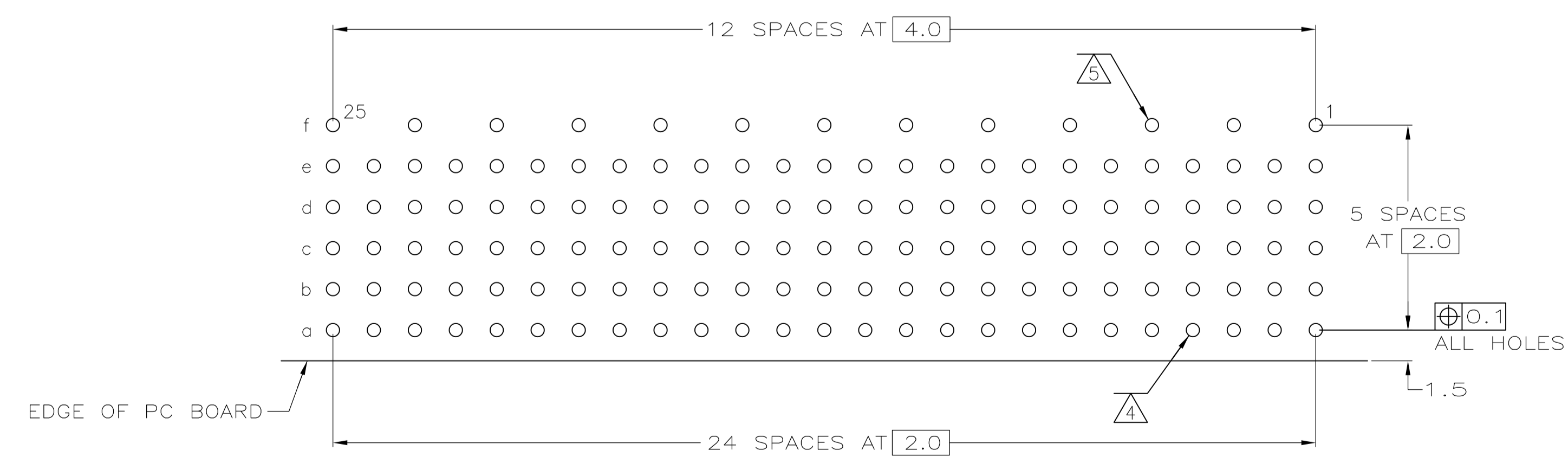
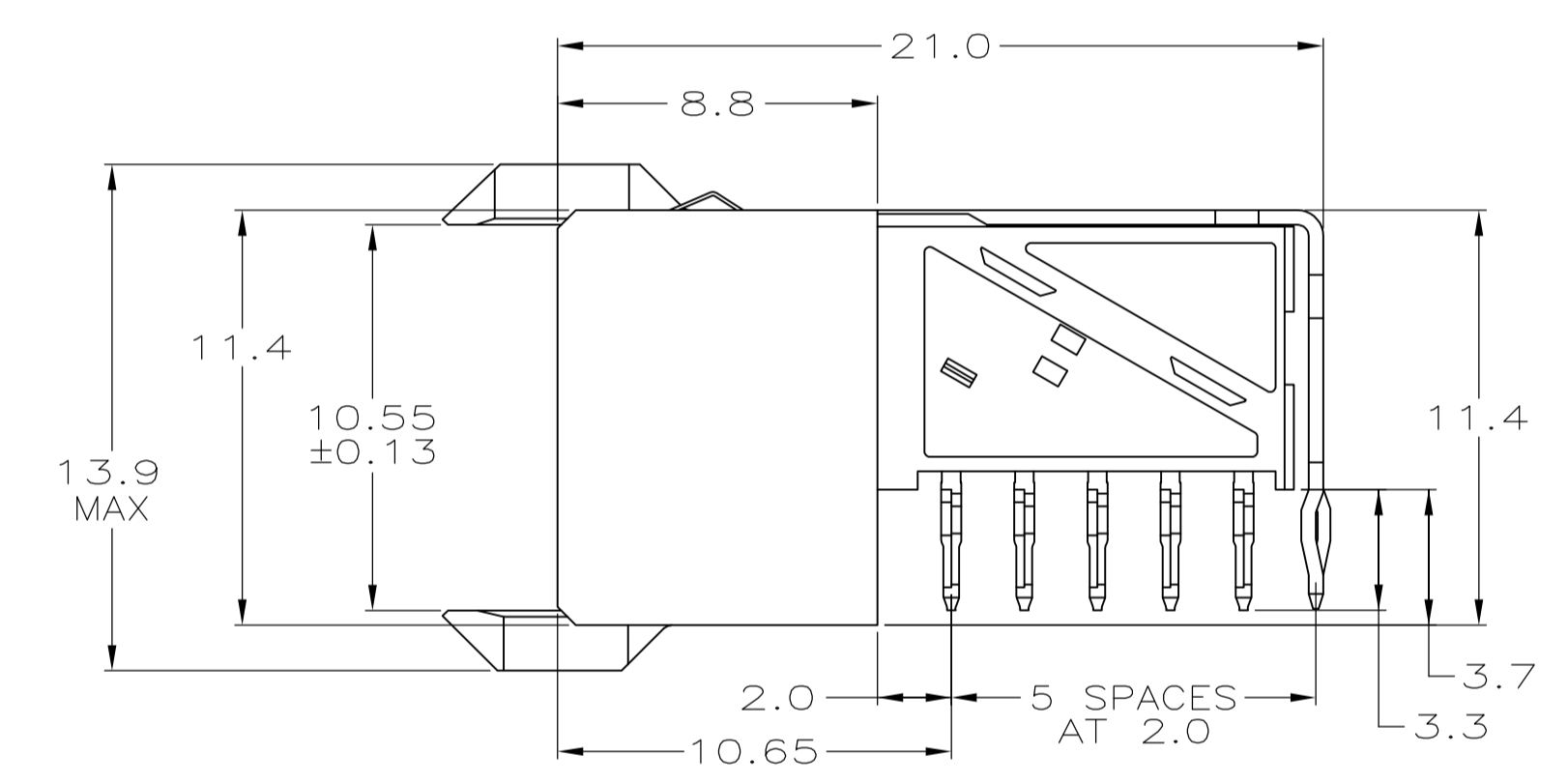
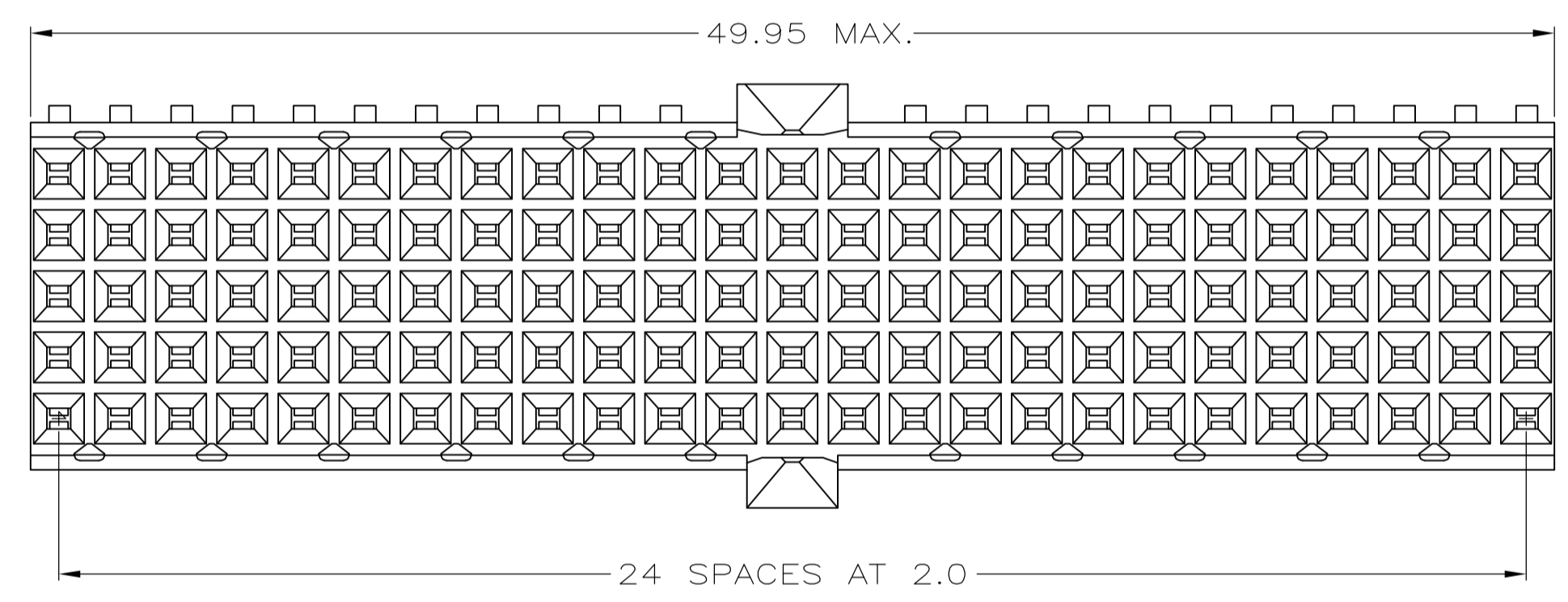

COMPONENT SIDE AS SHOWN
 RECOMMENDED PCB HOLE LAYOUT

PCB HOLE DIMENSIONS FOR ACTION PIN
 DRILLED HOLE: 0.700±0.025mm
 FINISHED HOLE: 0.55 TO 0.65mm
 CU-THICKNESS: 0.025 TO 0.050mm
 SN/PB-THICKNESS: 0.004 TO 0.010mm

646547-4	
3-646547-0	
646547-1	
FINISH	PART NUMBER

THIS DRAWING IS A CONTROLLED DOCUMENT.

DIMENSIONS:	TOLERANCES UNLESS OTHERWISE SPECIFIED:	DIN	L. BRINER	4/13/99	Tyco Electronics Corporation Harrisburg, PA 17105-3608
mm	0-PLC ± 1-PLC ± 2-PLC ±0.1 3-PLC ± 4-PLC ± ANGLES ±	CHK	G. SKIPPER	4/13/99	
MATERIAL	SEE TABLE	APVD	G. SKIPPER	4/13/99	NAME
		PRODUCT SPEC			RECEPTACLE ASSEMBLY, Z-PACK 2mm HM, TYPE A/B
		APPLICATION SPEC			SIZE
		WEIGHT		A1	CAGE CODE
		CUSTOMER DRAWING		00779	DRAWING NO
				646547	RESTRICTED TO
					SCALE
				5:1	SHEET
				1 OF 1	REV
					F