



# STE140NF20D

N-channel 200 V, 10 mΩ typ., 140 A STripFET™ II Power MOSFET  
(with fast diode) in an ISOTOP package

Datasheet – production data

## Features

Type	V <sub>DSS</sub>	R <sub>DS(on)</sub> max	I <sub>D</sub>
STE140NF20D	200 V	< 0.012 Ω	140 A

- Exceptional dv/dt capability
- Low gate charge
- 100% avalanche tested

## Applications

Switching applications

## Description

This Power MOSFET is produced using STMicroelectronics' unique STripFET™ process, which is specifically designed to minimize input capacitance and gate charge. The device offers extremely fast switching performance thanks to the intrinsic fast body diode, making the device ideal for hard switching topologies.

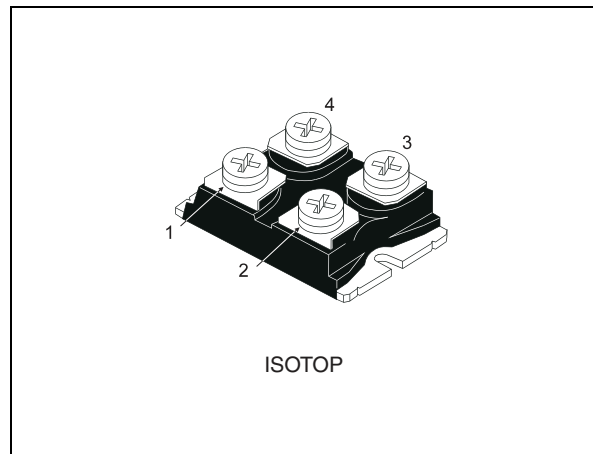

Figure 1. Internal schematic diagram

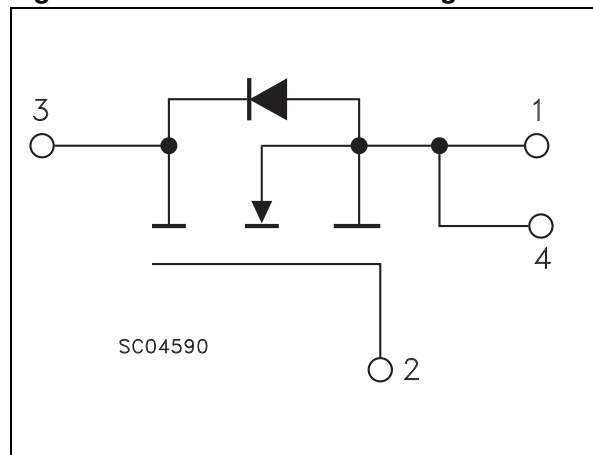

Table 1. Device summary

Order code	Marking	Package	Packaging
STE140NF20D	140NF20D	ISOTOP	Tube

# Contents

<b>1</b>	<b>Electrical ratings</b> .....	<b>3</b>
<b>2</b>	<b>Electrical characteristics</b> .....	<b>4</b>
	2.1 Electrical characteristics (curves) .....	6
<b>3</b>	<b>Test circuits</b> .....	<b>9</b>
<b>4</b>	<b>Package mechanical data</b> .....	<b>10</b>
<b>5</b>	<b>Revision history</b> .....	<b>13</b>

# 1 Electrical ratings

**Table 2. Absolute maximum ratings**

Symbol	Parameter	Value	Unit
$V_{DS}$	Drain-source voltage	200	V
$V_{GS}$	Gate-source voltage	$\pm 20$	V
$I_D$	Drain current (continuous) at $T_C = 25\text{ }^\circ\text{C}$	140	A
$I_D$	Drain current (continuous) at $T_C=100\text{ }^\circ\text{C}$	88	A
$I_{DM}^{(1)}$	Drain current (pulsed)	560	A
$P_{TOT}$	Total dissipation at $T_C = 25\text{ }^\circ\text{C}$	500	W
$I_{AR}^{(2)}$	Avalanche current, repetitive or not repetitive	140	A
$E_{AS}^{(3)}$	Single pulse avalanche energy	800	mJ
$dv/dt^{(4)}$	Peak diode recovery voltage slope	25	V/ns
$V_{ISO}$	Insulation withstand voltage (AC-RMS)	2500	V
$T_J$ $T_{stg}$	Operating junction temperature Storage temperature	- 55 to 150	$^\circ\text{C}$

1. Pulse width limited by safe operating area
2. Pulse width limited by  $T_{jmax}$
3. Strating  $T_j = 25\text{ }^\circ\text{C}$ ,  $I_D = I_{AR}$ ,  $V_{DD} = 50\text{ V}$
4.  $I_{SD} \leq 140\text{ A}$ ,  $di/dt \leq 1000\text{ A}/\mu\text{s}$ ,  $V_{DD} \leq 80\% V_{(BR)DSS}$

**Table 3. Thermal resistance**

Symbol	Parameter	Value	Unit
$R_{thj-case}$	Thermal resistance junction-case	0.25	$^\circ\text{C}/\text{W}$
$R_{thj-amb}$	Thermal resistance junction-ambient	40	$^\circ\text{C}/\text{W}$

## 2 Electrical characteristics

( $T_{CASE} = 25\text{ °C}$  unless otherwise specified)

**Table 4. On/off states**

Symbol	Parameter	Test conditions	Min.	Typ.	Max.	Unit
$V_{(BR)DSS}$	Drain-source breakdown voltage	$I_D = 1\text{ mA}$ , $V_{GS} = 0$	200			V
$I_{DSS}$	Zero gate voltage drain current ( $V_{GS} = 0$ )	$V_{DS} = 200\text{ V}$ , $V_{DS} = 200\text{ V}$ , $T_C = 125\text{ °C}$			10 100	$\mu\text{A}$ $\mu\text{A}$
$I_{GSS}$	Gate body leakage current ( $V_{DS} = 0$ )	$V_{GS} = \pm 20\text{ V}$			$\pm 100$	nA
$V_{GS(th)}$	Gate threshold voltage	$V_{DS} = V_{GS}$ , $I_D = 250\text{ }\mu\text{A}$	2	3	4	V
$R_{DS(on)}$	Static drain-source on resistance	$V_{GS} = 10\text{ V}$ , $I_D = 70\text{ A}$		10	12	m $\Omega$

**Table 5. Dynamic**

Symbol	Parameter	Test conditions	Min.	Typ.	Max.	Unit
$C_{iss}$	Input capacitance	$V_{DS} = 25\text{ V}$ , $f = 1\text{ MHz}$ , $V_{GS} = 0$	-	11100	-	pF
$C_{oss}$	Output capacitance			2190		
$C_{rss}$	Reverse transfer capacitance			334		
$C_{o(tr)}^{(1)}$	Equivalent capacitance time related	$V_{DS} = 0\text{ to }160\text{ V}$ , $V_{GS} = 0$ ,	-	1525	-	pF
$C_{o(er)}^{(2)}$	Equivalent capacitance energy related			1139		
$R_g$	Intrinsic gate resistance	$f = 1\text{ MHz}$ open drain	-	1.4	-	$\Omega$
$Q_g$	Total gate charge	$V_{DD} = 160\text{ V}$ , $I_D = 140\text{ A}$ , $V_{GS} = 10\text{ V}$ (see Figure 16)	-	338	-	nC
$Q_{gs}$	Gate-source charge			47		
$Q_{gd}$	Gate-drain charge			183		

1. Time related is defined as a constant equivalent capacitance giving the same charging time as  $C_{oss}$  when  $V_{DS}$  increases from 0 to 80%  $V_{DSS}$
2. Energy related is defined as a constant equivalent capacitance giving the same stored energy as  $C_{oss}$  when  $V_{DS}$  increases from 0 to 80%  $V_{DSS}$

**Table 6. Switching times**

Symbol	Parameter	Test conditions	Min.	Typ.	Max.	Unit
$t_{d(on)}$	Turn-on delay time	$V_{DD} = 100\text{ V}$ , $I_D = 70\text{ A}$ , $R_G = 4.7\ \Omega$ , $V_{GS} = 10\text{ V}$ (see Figure 15)	-	232	-	ns
$t_r$	Rise time			218		ns
$t_{d(off)}$	Turn-off delay time			283		ns
$t_f$	Fall time			250		ns

**Table 7. Source drain diode**

Symbol	Parameter	Test conditions	Min.	Typ.	Max.	Unit
$I_{SD}$	Source-drain current		-		140	A
$I_{SDM}^{(1)}$	Source-drain current (pulsed)		-		560	A
$V_{SD}^{(2)}$	Forward on voltage	$I_{SD} = 140\text{ A}$ , $V_{GS} = 0$	-		1.5	V
$t_{rr}$	Reverse recovery time	$I_{SD} = 140\text{ A}$ , $di/dt = 100\text{ A}/\mu\text{s}$ , $V_{DD} = 60\text{ V}$	-	190		ns
$Q_{rr}$	Reverse recovery charge			1.4		nC
$I_{RRM}$	Reverse recovery current			14		A
$t_{rr}$	Reverse recovery time	$I_{SD} = 140\text{ A}$ , $di/dt = 100\text{ A}/\mu\text{s}$ , $V_{DD} = 60\text{ V}$ , $T_J = 150\text{ }^\circ\text{C}$	-	257		ns
$Q_{rr}$	Reverse recovery charge			2.4		$\mu\text{C}$
$I_{RRM}$	Reverse recovery current			18		A

1. Pulse width limited by safe operating area
2. Pulsed: pulse duration = 300  $\mu\text{s}$ , duty cycle 1.5%

## 2.1 Electrical characteristics (curves)

Figure 2. Safe operating area

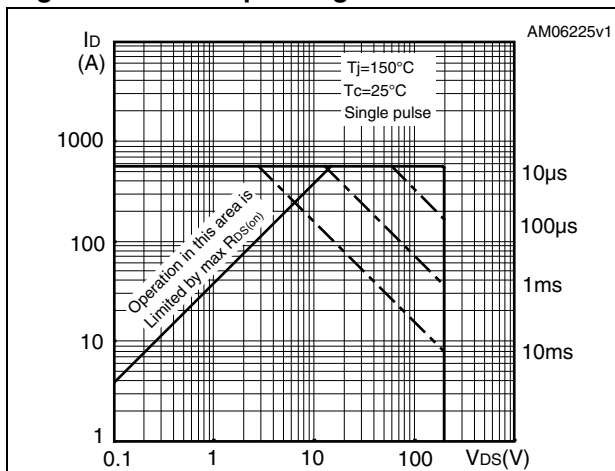

Figure 3. Thermal impedance

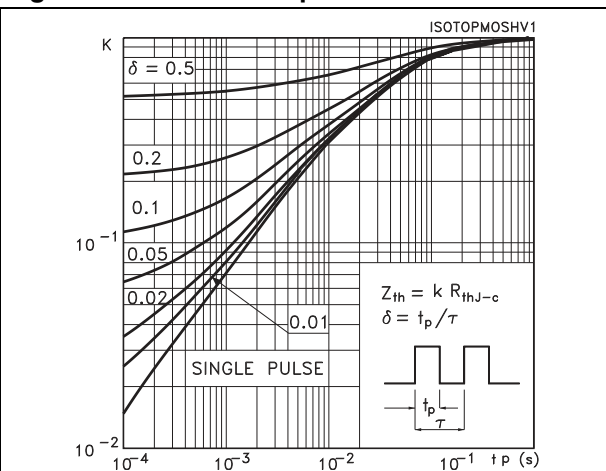

Figure 4. Output characteristics

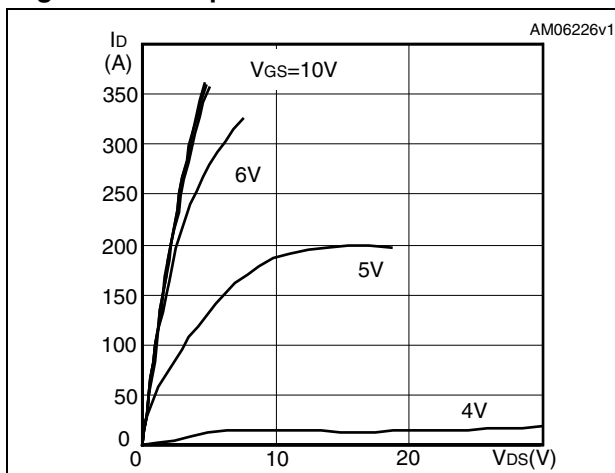

Figure 5. Transfer characteristics

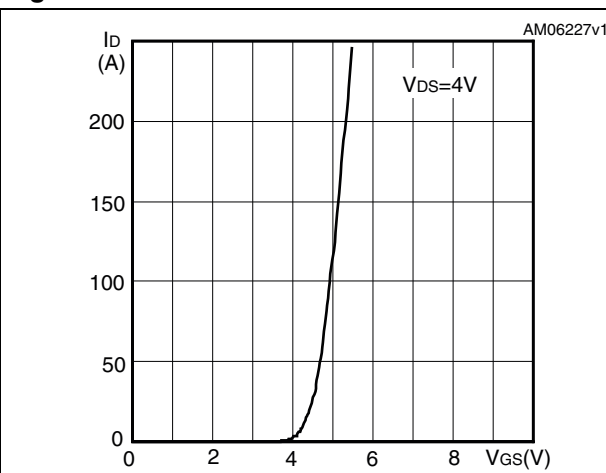

Figure 6. Gate charge vs gate-source voltage

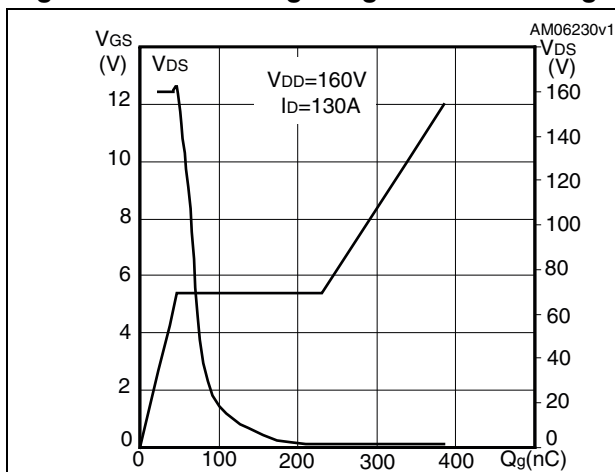

Figure 7. Static drain-source on-resistance

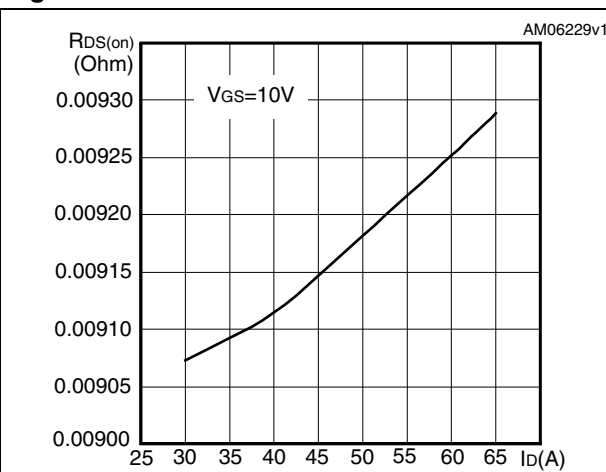

Figure 8. Capacitance variations

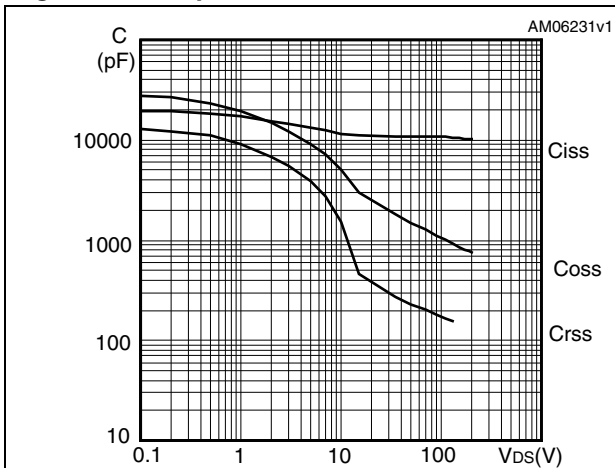

Figure 9. Output capacitance stored energy

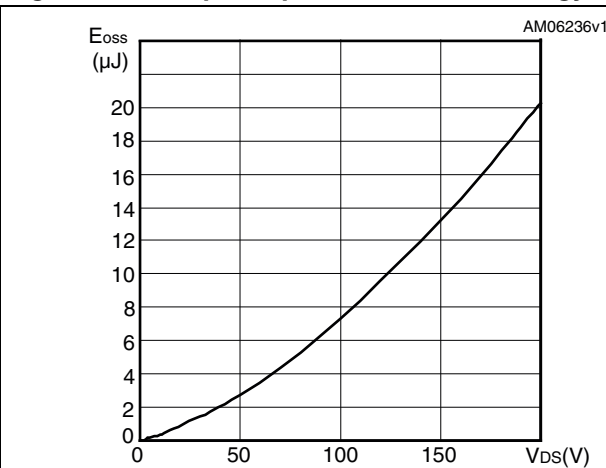

Figure 10. Normalized gate threshold voltage vs temperature

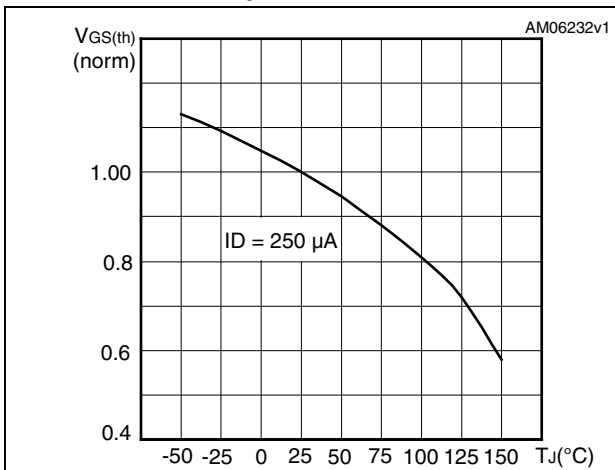

Figure 11. Normalized on resistance vs temperature

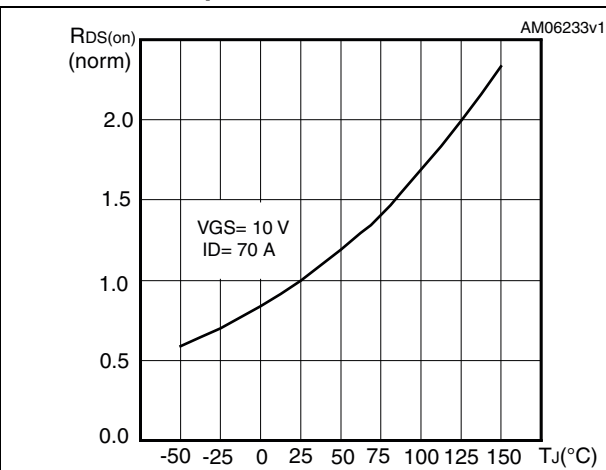

Figure 12. Source-drain diode forward characteristics

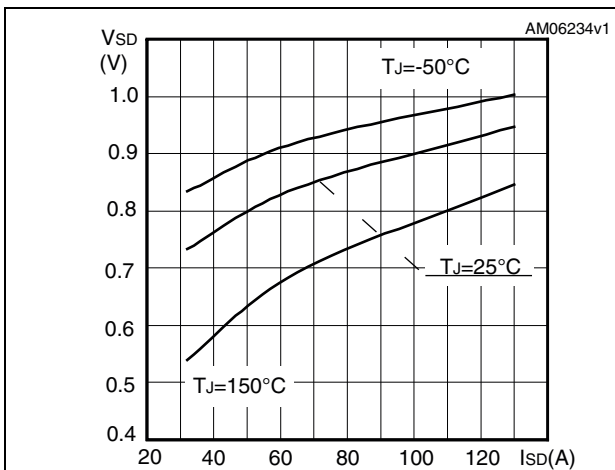

Figure 13. Normalized BV<sub>DSS</sub> vs temperature

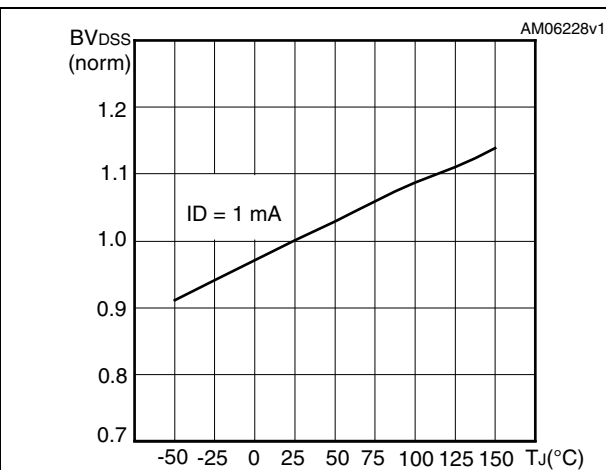
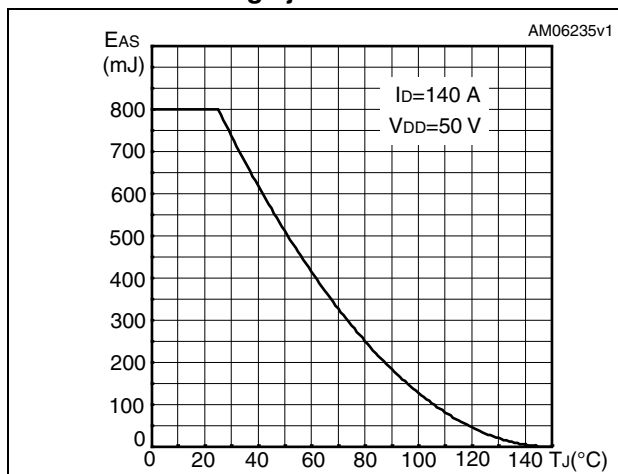

Figure 14. Maximum avalanche energy vs starting Tj





### 3 Test circuits

Figure 15. Switching times test circuit for resistive load

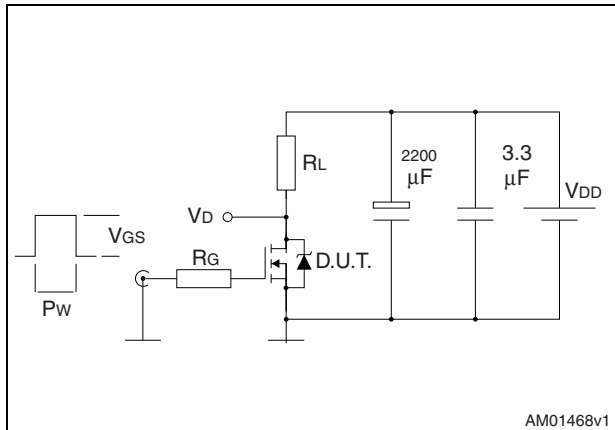

AM01468v1

Figure 16. Gate charge test circuit

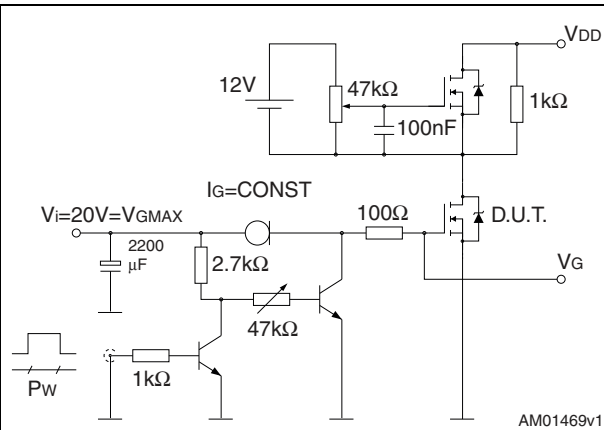

AM01469v1

Figure 17. Test circuit for inductive load switching and diode recovery times

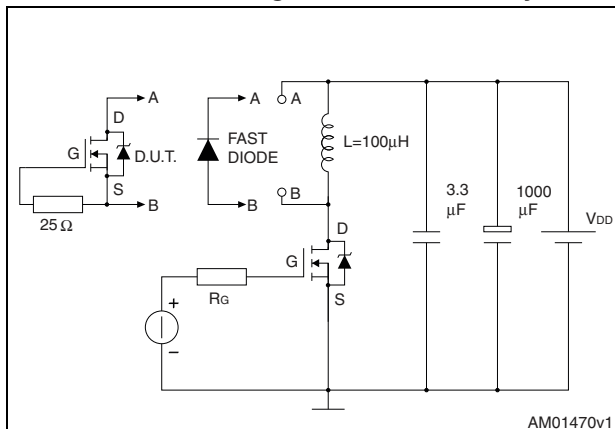

AM01470v1

Figure 18. Unclamped inductive load test circuit

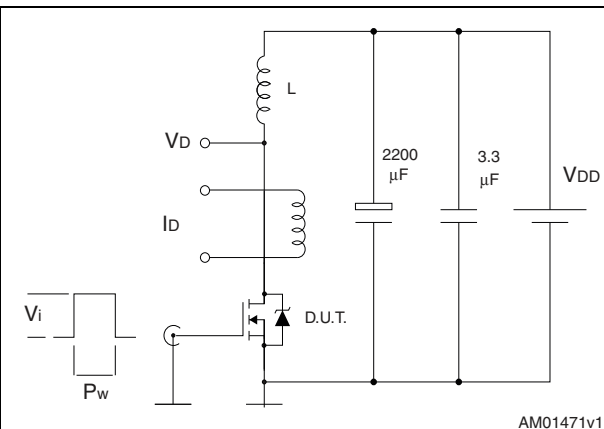

AM01471v1

Figure 19. Unclamped inductive waveform

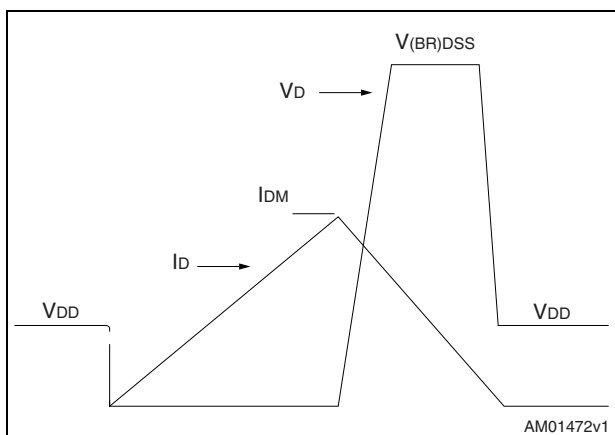

AM01472v1

Figure 20. Switching time waveform

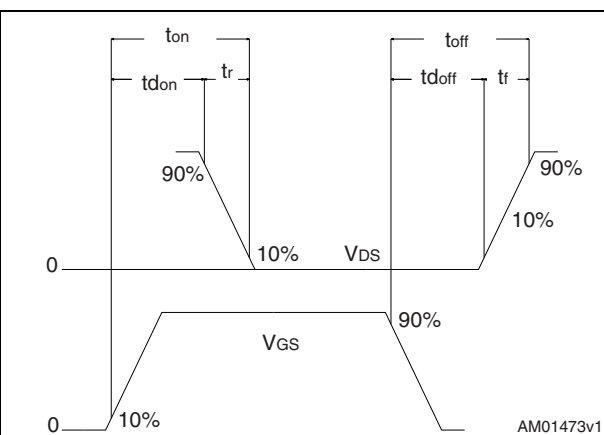

AM01473v1

## 4 Package mechanical data

In order to meet environmental requirements, ST offers these devices in different grades of ECOPACK® packages, depending on their level of environmental compliance. ECOPACK® specifications, grade definitions and product status are available at: [www.st.com](http://www.st.com). ECOPACK is an ST trademark.

**Table 8. ISOTOP mechanical data**

Dim.	mm		
	Min.	Typ.	Max.
A	11.76		12.19
A1	8.92		9.58
B	7.80		8.18
C	0.76		0.84
C2	1.98		2.13
D	38		38.20
D1	31.50		31.70
E	25.20		25.45
E2	24.59		25.07
G	14.91		15.09
G1	12.57		12.83
F	4.09		4.19
F1	4.67		4.93
ΦP	4.09		4.27
P1	4.06		4.32
Q	26.54		26.90
R	3.94		4.42
S	30.12		30.30
T	3.30		3.61
U	6.88		7.09

Figure 21. ISOTOP drawing

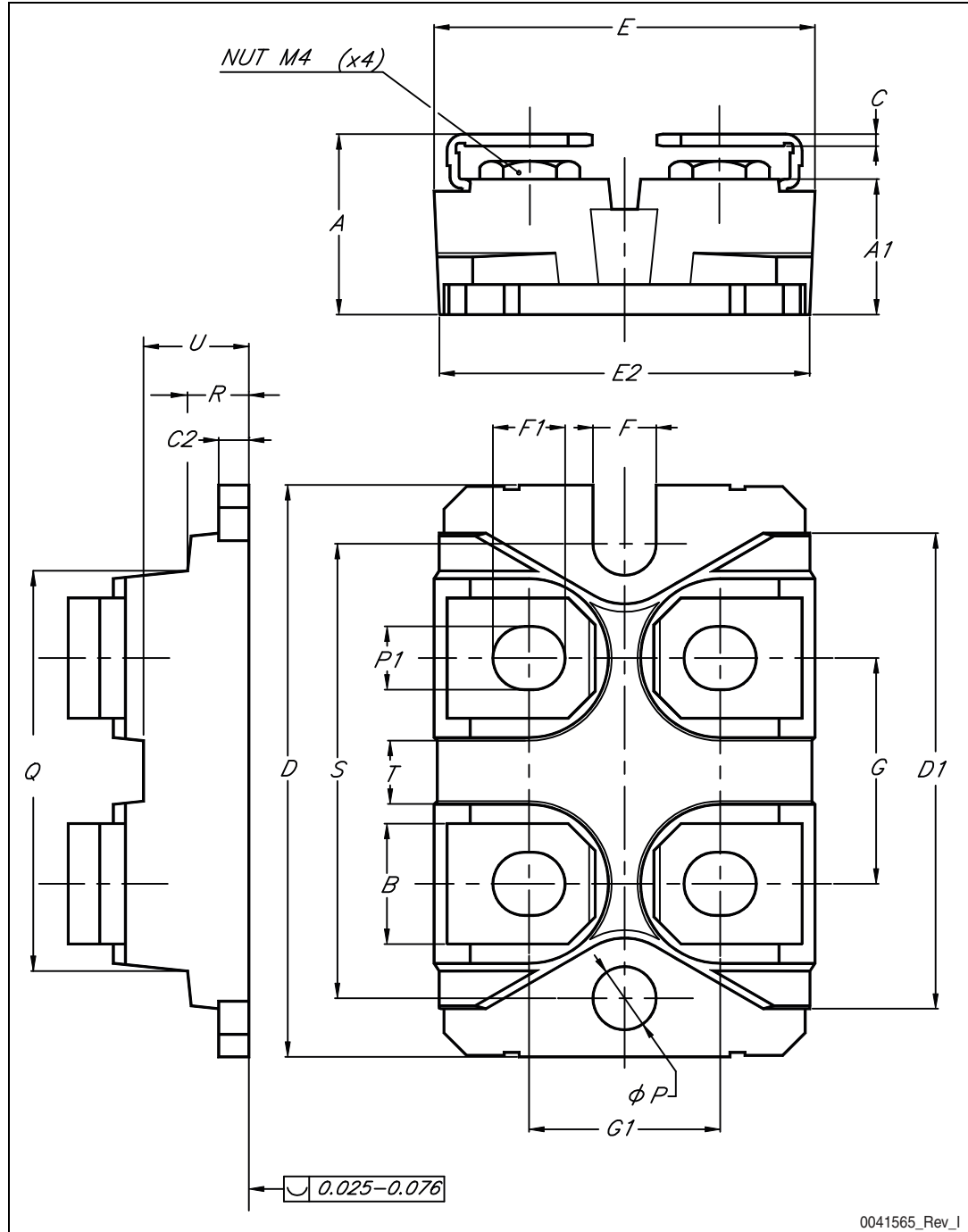

## 5 Revision history

**Table 9. Document revision history**

Date	Revision	Changes
27-Jan-2009	1	First release
18-Jan-2010	2	Document status promoted from preliminary data to datasheet.
01-Jul-2010	3	Inserted $V_{ISO}$ parameter in <a href="#">Table 2: Absolute maximum ratings</a>
17-Oct-2012	4	Updated: <a href="#">Figure 1, 5, 6, 10, 11, 13</a> . Updated: $I_{SD}$ value in note 4 (below <a href="#">Table 2: Absolute maximum ratings</a> ). Updated: $I_{DSS}$ and $I_{GSS}$ values (test conditions) in <a href="#">Table 4: On/off states</a> . Updated: <a href="#">Section 4: Package mechanical data</a> . Minor text changes.

**Please Read Carefully:**

Information in this document is provided solely in connection with ST products. STMicroelectronics NV and its subsidiaries ("ST") reserve the right to make changes, corrections, modifications or improvements, to this document, and the products and services described herein at any time, without notice.

All ST products are sold pursuant to ST's terms and conditions of sale.

Purchasers are solely responsible for the choice, selection and use of the ST products and services described herein, and ST assumes no liability whatsoever relating to the choice, selection or use of the ST products and services described herein.

No license, express or implied, by estoppel or otherwise, to any intellectual property rights is granted under this document. If any part of this document refers to any third party products or services it shall not be deemed a license grant by ST for the use of such third party products or services, or any intellectual property contained therein or considered as a warranty covering the use in any manner whatsoever of such third party products or services or any intellectual property contained therein.

**UNLESS OTHERWISE SET FORTH IN ST'S TERMS AND CONDITIONS OF SALE ST DISCLAIMS ANY EXPRESS OR IMPLIED WARRANTY WITH RESPECT TO THE USE AND/OR SALE OF ST PRODUCTS INCLUDING WITHOUT LIMITATION IMPLIED WARRANTIES OF MERCHANTABILITY, FITNESS FOR A PARTICULAR PURPOSE (AND THEIR EQUIVALENTS UNDER THE LAWS OF ANY JURISDICTION), OR INFRINGEMENT OF ANY PATENT, COPYRIGHT OR OTHER INTELLECTUAL PROPERTY RIGHT.**

**UNLESS EXPRESSLY APPROVED IN WRITING BY TWO AUTHORIZED ST REPRESENTATIVES, ST PRODUCTS ARE NOT RECOMMENDED, AUTHORIZED OR WARRANTED FOR USE IN MILITARY, AIR CRAFT, SPACE, LIFE SAVING, OR LIFE SUSTAINING APPLICATIONS, NOR IN PRODUCTS OR SYSTEMS WHERE FAILURE OR MALFUNCTION MAY RESULT IN PERSONAL INJURY, DEATH, OR SEVERE PROPERTY OR ENVIRONMENTAL DAMAGE. ST PRODUCTS WHICH ARE NOT SPECIFIED AS "AUTOMOTIVE GRADE" MAY ONLY BE USED IN AUTOMOTIVE APPLICATIONS AT USER'S OWN RISK.**

Resale of ST products with provisions different from the statements and/or technical features set forth in this document shall immediately void any warranty granted by ST for the ST product or service described herein and shall not create or extend in any manner whatsoever, any liability of ST.

ST and the ST logo are trademarks or registered trademarks of ST in various countries.

Information in this document supersedes and replaces all information previously supplied.

The ST logo is a registered trademark of STMicroelectronics. All other names are the property of their respective owners.

© 2012 STMicroelectronics - All rights reserved

STMicroelectronics group of companies

Australia - Belgium - Brazil - Canada - China - Czech Republic - Finland - France - Germany - Hong Kong - India - Israel - Italy - Japan - Malaysia - Malta - Morocco - Philippines - Singapore - Spain - Sweden - Switzerland - United Kingdom - United States of America

[www.st.com](http://www.st.com)

