

## General Description

The MultiDimension TMR9112 Tunneling Magnetoresistive (TMR) sensors are magnetoresistive Wheatstone bridges configured to measure magnetic fields reliably after exposure to large magnetic field or experiencing extreme temperature drift, which can be powered using a voltage or current supply. When power is applied, the magnetoresistive Wheatstone bridge converts any magnetic field applied along the sensing axis direction to a differential output voltage. In addition to the magnetoresistive bridge circuit, the TMR9112 also includes an initialization coil that is magnetically coupled to the TMR sensor. This MultiDimension patented feature permits proper magnetic domain alignment, even in an uncontrolled environment where large magnetic field exposure or temperature change is unavoidable, resulting in a sensor that can provide stable low hysteresis and low offset output. The TMR9112 is assembled in a 6mm X 6 mm X 0.75 mm LGA package.

## Features and Benefits

- Tunneling Magnetoresistance (TMR) Technology
- Ultra High Sensitivity (~100 mV/V/Oe)
- Ultra Low Noise Spectral Density ( $150 \text{ pT}/\sqrt{\text{Hz}}$  @1Hz)
- Very Low Power Consumption
- Excellent Thermal Stability, Small Offset, and Low Hysteresis
- Initialization Coil for Accurate Operation After High Magnetic Field Exposure
- Compatible with Wide Range of Supply Voltages

## Applications

- Weak Magnetic Field Sensing
- Current Sensors
- Position and Displacement Sensing
- Bio-medical Sensing
- Magnetic Communication
- Precision Sensing in Uncontrolled Magnetic Environments

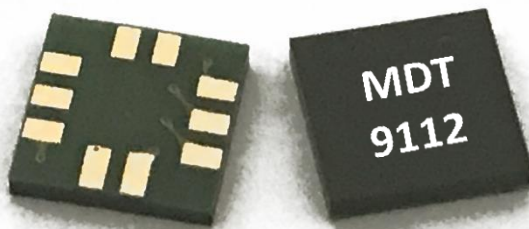

## Transfer Curve

The following figures show the response of the TMR9112 to an applied magnetic field in ranges of  $\pm 1$  Oe and  $\pm 10$  Oe when the TMR9112 is biased at 1 V. When the operating field is less than 10 Oe, the coercivity remains small, and there is no need to use the initialization coil.

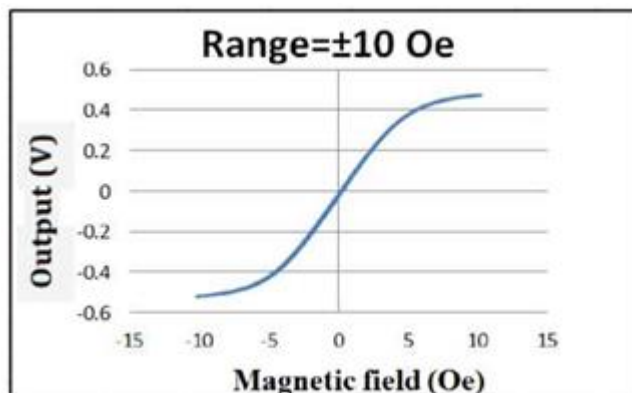
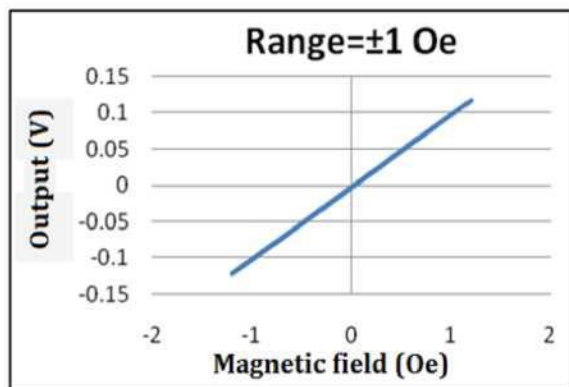

## Absolute Maximum Ratings

Parameter	Symbol	Limit	Unit
Supply Voltage	$V_{cc}$	7	V
Reverse Supply Voltage	$V_{RCC}$	7	V
Max Exposed Field	$H_e$	4000	Oe <sup>(1)</sup>
ESD Voltage	$V_{ESD}$	4000	V
Operating Temperature	$T_A$	-40~125	c
Storage Temperature	$T_{stg}$	-50 ~150	c

## Performance Specifications ( $V_{cc} = 1.0 V$ , $T_A = 25 C$ )

Parameter	Symbol	Conditions	Min	Typ	Max	Unit
Supply Voltage	$V_{cc}$	Normal Operating		1	7	V
Supply Current	$I_{cc}$	Output Open		20 <sup>(2)</sup>		$\mu A$
Resistance	R			50		kOhm
Sensitivity	SEN	Fit $\pm 1 Oe$		100		mV/V/Oe
Saturation Field	$H_{sat}$			$\pm 8$		Oe
Non -Linearity	NONL	Fit $\pm 1 Oe$		0.5		%FS
Offset Voltage	$V_{offset}$			15		mV/V
Hysteresis	$H_c$	Sweep $\pm 2 Oe$		0.006	0.02	Oe
Hysteresis Initialization Pulsed	Init_ $H_c$	Sweep $H_p <  150 Oe $	0.0006* $H_p$	0.0012* $H_p$	0.0018* $H_p$	Oe
Equivalent Magnetic Noise Density	$S_B$	@1Hz		150		$pT/\sqrt{Hz}$

Notes:

- (1) 1 Oe (Oersted) = 1 Gauss in air = 0.1 millitesla = 79.8 A/m.
- (2)  $I_{CC} = V_{CC}/R$ ,  $I_{cc}$  will vary with different R, and it can be customized accordingly.

### Initialization Coil

Parameter	Symbol	Conditions	Min	Typ	Max	Unit
Resistance	$R_{coil}$		0.6	0.8	1.0	ohm
Current	$I_{coil}$	<10 $\mu s$ current pulse, 0.1% Duty Cycle		2	5	A
Resistance Tempco	RTC			0.393		%/C

## Sensor Equivalent Magnetic Noise

The following figure illustrates the Power Spectral Density (PSD) of the TMR9112 intrinsic noise referred to magnetic field. The  $1/f$  noise is approximately  $150 \text{ pT}/\sqrt{\text{Hz}}$  @ 1 Hz, and the white noise is approximately  $4.5 \text{ pT}/\sqrt{\text{Hz}}$  @ 10 kHz.

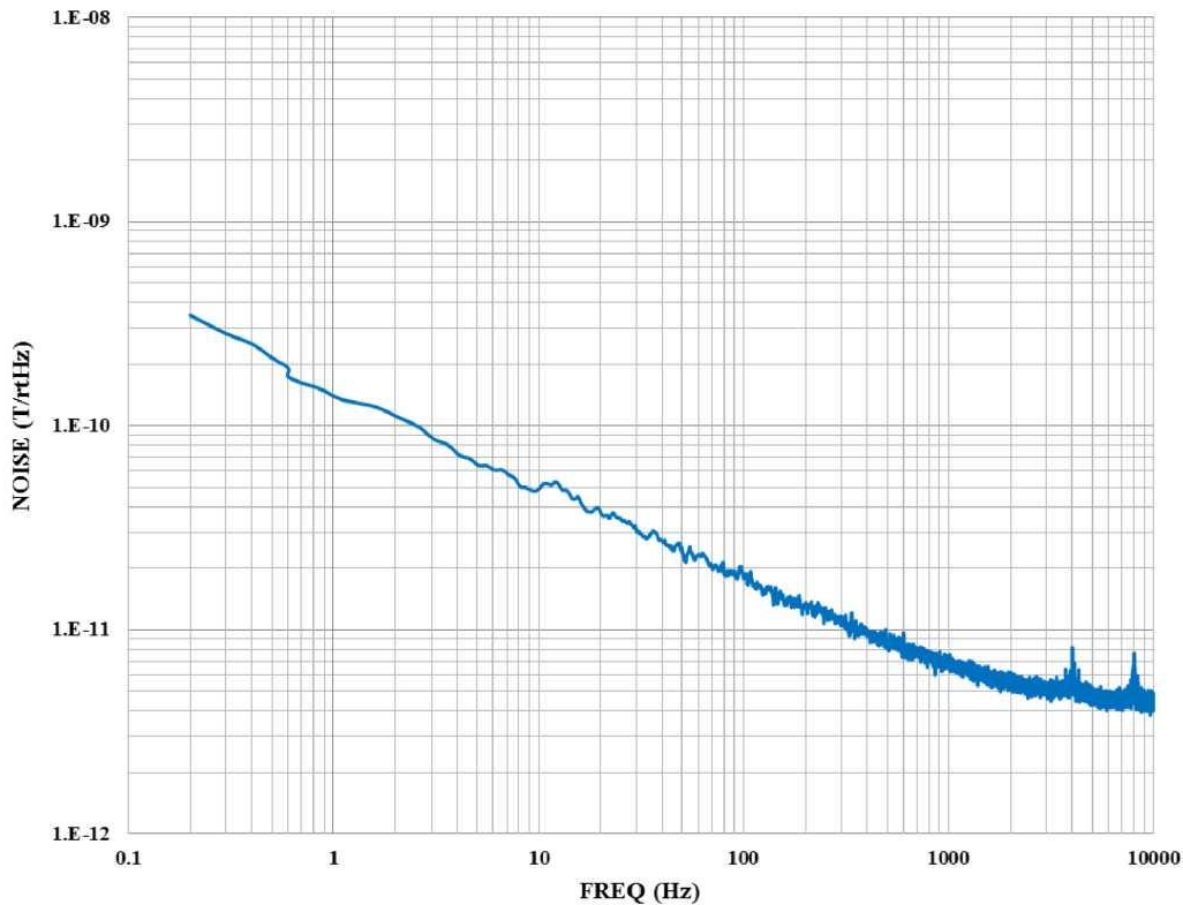

## Sensor Initialization Overview

A coil is provided within the sensor package to perform a sensor magnetic initialization after the sensor has been exposed to a large magnetic field or under other circumstances where demagnetization of the sensor might be caused, such as temperature change or stress.

Generally, the performance of magnetic sensors, such as anisotropic magnetoresistance (AMR) and giant magnetoresistance (GMR), as well as TMR are all dependent on the magnetic field, temperature, and stress exposure history. Large magnetic fields applied along the sensing direction produce larger hysteresis values than small fields, and can produce a shift in device calibration and offset by demagnetizing the ferromagnetic materials used in the sensor. Large magnetic fields can come from many sources, including permanent magnets placed near the sensor, current spikes in power cables, transformers, etc. Temperature change or application of a stress on the sensor package can also cause the sensor elements to demagnetize. This demagnetization does not destroy the sensor, but it can cause a shift in operating parameters. For the TMR9112, fields in excess of 10 Oe can affect sensor accuracy. The sensor can be restored to normal operating

condition, by applying a quick large magnetic field pulse along the direction perpendicular to the sensing axis. The initialization coil provides a simple low power method for initializing the sensor back to the preferred magnetic condition, thereby restoring normal operation.

## Initialization Pulsing Circuits

The MultiDimension TMR9112 is equipped with a spiral coil underneath the sensor die that can be used to apply a sufficient initialization magnetic field through the application of fast electric current pulses. A reliable circuit for providing fast current pulses is shown below. The clock signal is a 5 V logic signal. It may be a repetitive digital clock signal or a signal sent on demand from a microcontroller based on field exposure or time. This circuit is capable of providing 2.5 A pulses with a duration of several microseconds, which are sufficient to realign magnetic domains in the flux concentrators. Although the initialization current pulse has large peak amplitude, the short duration reduces the RMS current consumption to a low enough value that the entire system can be powered from a USB port or a battery.

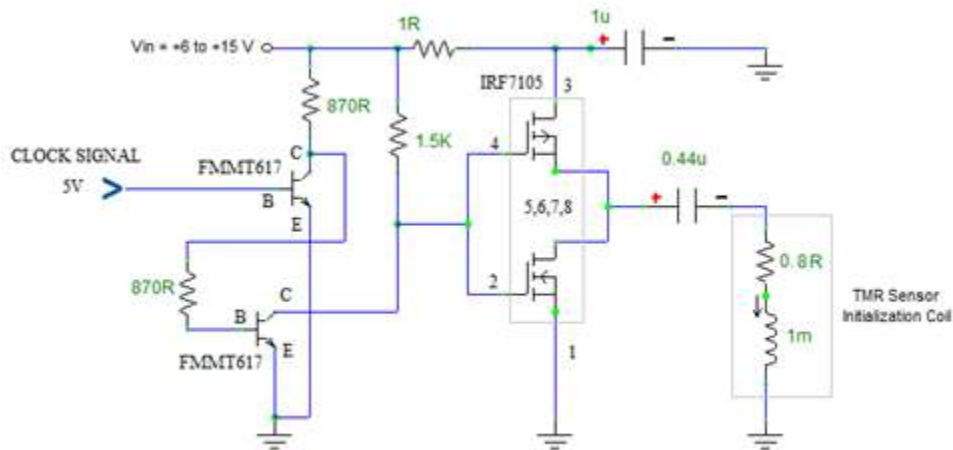

The 15 V  $V_{in}$  supply may be sourced from a 5 V USB port supply using a Maxim MAX1683 level shifter circuit configured as a voltage tripler as shown below.

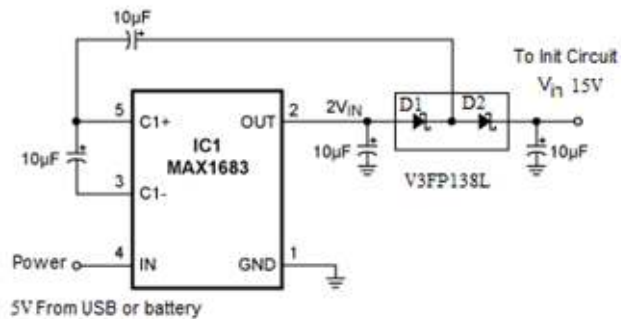

The TMR9112 sensors may also be operated without a microprocessor by using a timer circuit, such as an LM555 timer. A simple circuit that does not require a microcontroller and provides analog output is shown below. Bandwidth may be adjusted by changing the pulse frequency  $f_p$  and filter cutoff  $f_c$ , but higher bandwidth will result in increased power consumption.

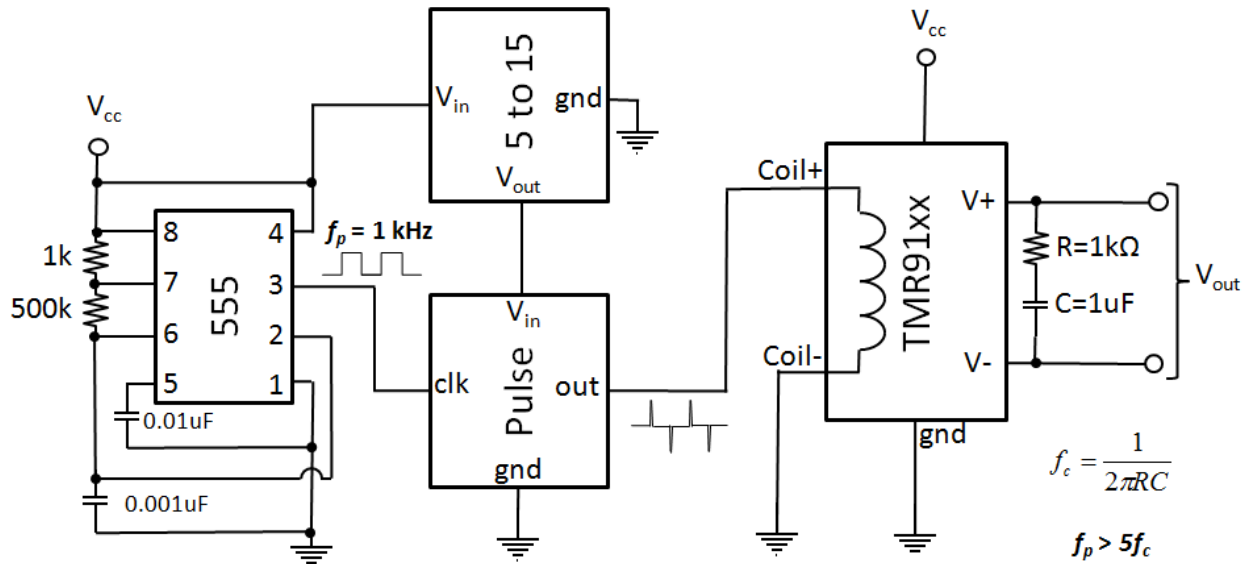

### Pin Configuration

(Arrow indicates direction of applied field that generates a positive output voltage.)

**Top view**

Pin No.	Pin Name	Pin Function
1	Coil-	Negative Initialization Coil Input
2,3	NC	Not Connected
4,5	NC	Not Connected
6	GND	Ground
7	V+	Positive Differential Output
8	V-	Negative Differential Output
9	Vcc	Power supply
10	Coil+	Positive Initialization Coil Input

## Package Information

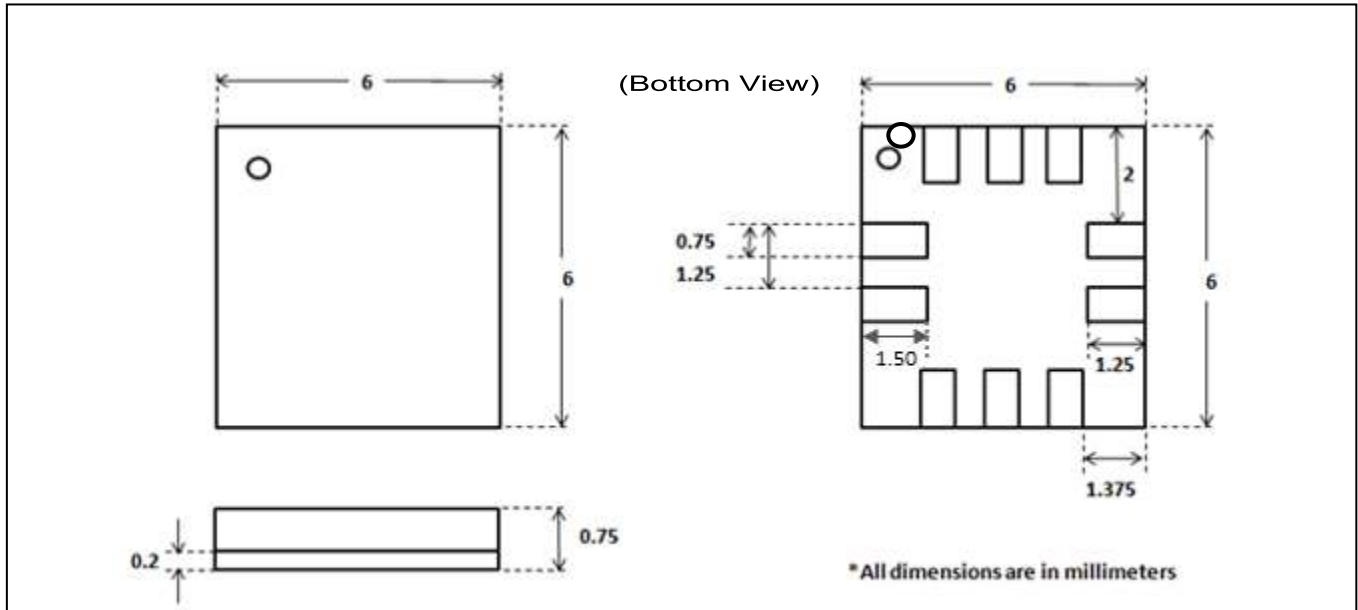

## TMR Sensor Position

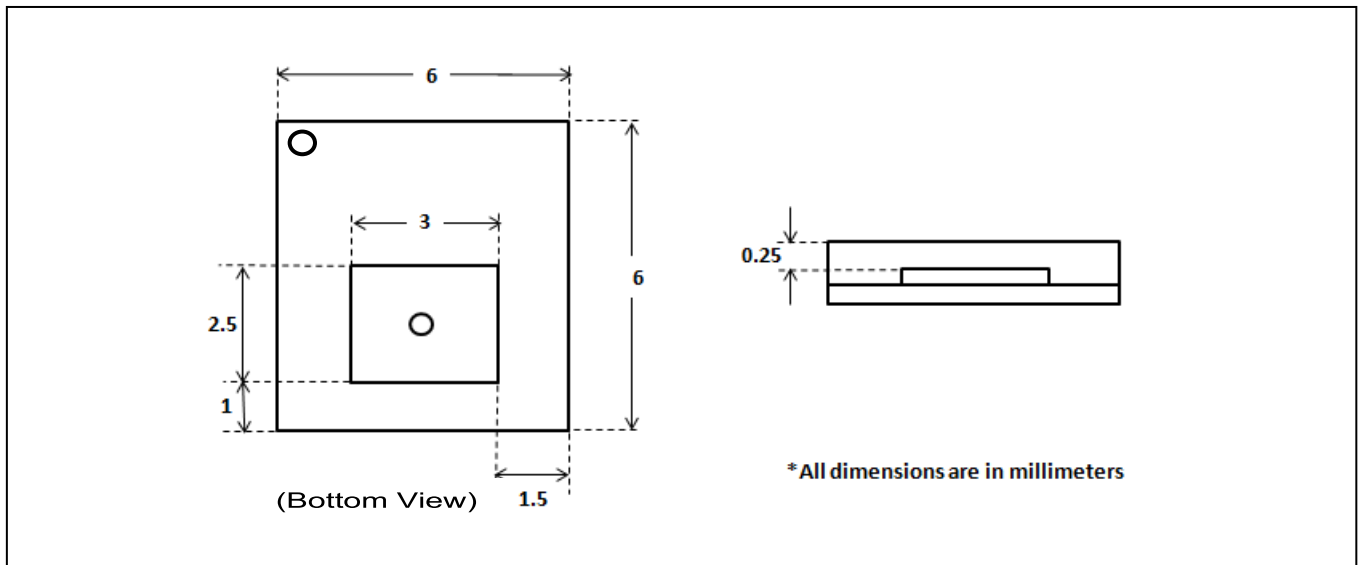



**MultiDimension Technology Co., Ltd.**

Address: No.7 Guangdong Road, Zhangjiagang Free Trade Zone, Jiangsu, 215634, China

Web: [www.dowaytech.com/en](http://www.dowaytech.com/en)

Email: [info@dowaytech.com](mailto:info@dowaytech.com)

The information provided herein by MultiDimension Technology Co., Ltd. (hereinafter MultiDimension) is believed to be accurate and reliable. Publication neither conveys nor implies any license under patent or other industrial or intellectual property rights. MultiDimension reserves the right to make changes to product specifications for the purpose of improving product quality, reliability, and functionality. MultiDimension does not assume any liability arising out of the application and use of its products. MultiDimension's customers using or selling this product for use in appliances, devices, or systems where malfunction can reasonably be expected to result in personal injury do so at their own risk and agree to fully indemnify MultiDimension for any damages resulting from such applications.