

Transfer or duplication of this document as well as the utilisation or communication of its content are not permitted unless express consent is granted. Violations give rise to claims for damages. All rights reserved in case of patent, utility model or design patent registrations.

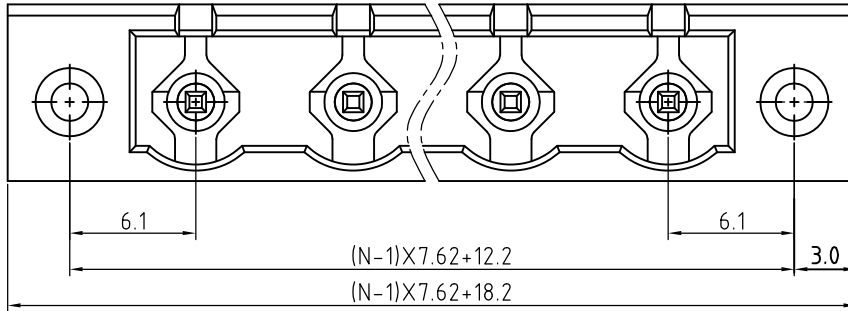

N=Number of contacts

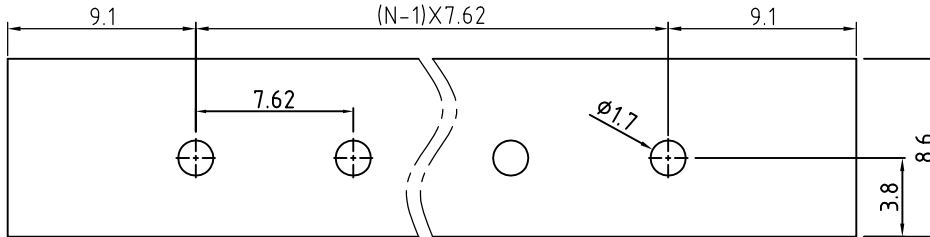
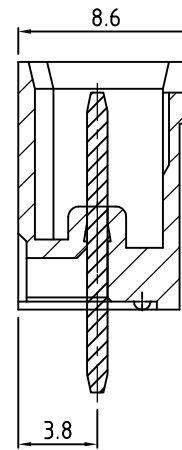
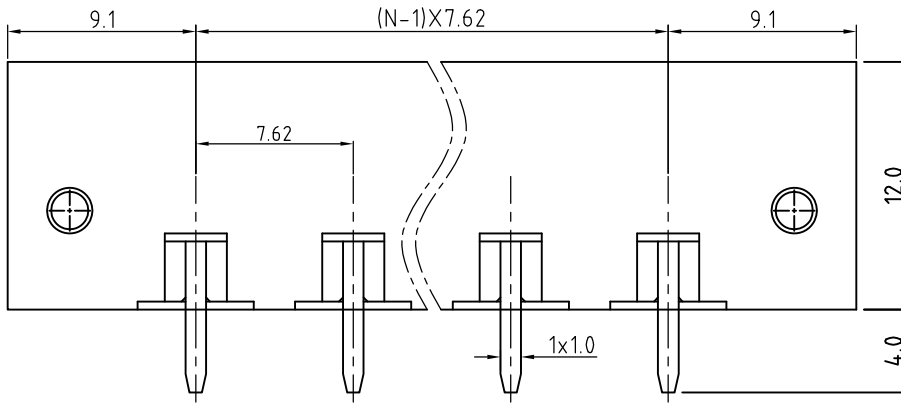

Technical Data:
 Electrical
 Pitch: 7.62mm
 Voltage rating: 300V
 Current rating: 16 Amps
 Withstanding Voltage: 2500VAC(1min)
 Mechanical:
 Operating temperature: -40°C to +105°C
 Soldering temperature:
 Temperature= 250°C±10°C / 5 seconds max
 Safety approval: .
 RoHS Compliance

Part No.:

OSTOQXX0550

No. of Poles
 02 2 Poles
 03 3 Poles

 24 24 Poles

COLOR
 0: Black
 2: Red
 3: Orange
 4: Yellow
 5: Green (Standard)
 6: Blue
 8: Grey

Nonstandard colors
 Mins could apply

3	Flange nut	Copper Alloy		2
2	Pin	Copper Alloy	Tin plated	1xN
1	Body	PA66-30%GF UL94V		1
ITEM	NAME OF PART	MATERIAL	NOTES	Q"TY
DWG.	DATE	UNITS:	MM	SHEET: 1 OF 1
CHK.	DATE	SCALE:	NONE 4:1 (:)	REV.: A
APP.	DATE	TITLE:	OSTOQ SERIES 7.62MM WITH FLANGE VERTICAL	
		PART NO.	OSTOQXX0550	
		DWG NO.	OSTOQXX0550.DWG	
			X.	±0.50
			X.X	±0.30
			X.XX	±0.10
			X°	±1°

REV	△	DESCRIPTION	CHK.	DATE



ON-SHORE TECHNOLOGY, INC.