

## Synchronous Boost Converter with Voltage Detector

### General Description

The RT9276 is a synchronous boost converter, which is based on a fixed frequency Pulse-Width-Modulation (PWM) controller using a synchronous rectifier to obtain maximum efficiency. The converter provides a power supply solution for products powered by a variety of batteries such as single cell, dual cell alkaline, NiMH and NiCd battery. At light load currents, the converter enters power save mode to maintain a high efficiency over a wide load current range.

The output voltage can be programmed by an external resistor divider, or fixed at a certain voltage. Moreover, the converter can be disabled to minimize battery drain. During shutdown, the load is completely disconnected from the battery. The maximum peak current in the boost switch is limited to 2A for current limit.

For the RT9276, a low-EMI mode is implemented to reduce ringing of the inductor phase pin when the converter enters discontinuous conduction mode. Moreover, a voltage detector is built-in in the chip for low battery detection.

### Ordering Information

RT9276(-□□)□□

- Package Type  
QW : WDFN-10L 3x3 (W-Type)
- Lead Plating System  
G : Green (Halogen Free and Pb Free)
- Boost VOUT  
Default : Adjustable  
33 : 3.3V  
50 : 5.0V

Note :

Richtek products are :

- ▶ RoHS compliant and compatible with the current requirements of IPC/JEDEC J-STD-020.
- ▶ Suitable for use in SnPb or Pb-free soldering processes.

### Features

- True Load Disconnection During Shutdown
- Internal Synchronous Rectifier
- Up to 96% Efficiency
- Current Mode PWM Operation with Internal Compensation
- Low Start-Up Voltage
- Low Quiescent Current
- Internal Soft-Start Control
- Low Battery Comparator
- Low EMI Converter (Anti-Ringing)
- Power Save Mode for Improved Efficiency at Light Load Current
- Over Current Protection
- Short Circuit Protection
- Over Temperature Protection
- Over Voltage Protection
- Small WDFN-10L 3x3 Package
- RoHS Compliant and Halogen Free

### Applications

- All One-Cell, Two-Cell and Three-Cell Alkaline, NiCd, NiMH and Single-Cell Li Batteries
- Hand-Held Devices
- WLED Flash Light

### Pin Configurations

(TOP VIEW)

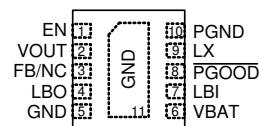

WDFN-10L 3x3

### Marking Information

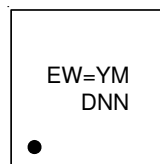

EW= : Product Code

YMDNN : Date Code

Typical Application Circuit

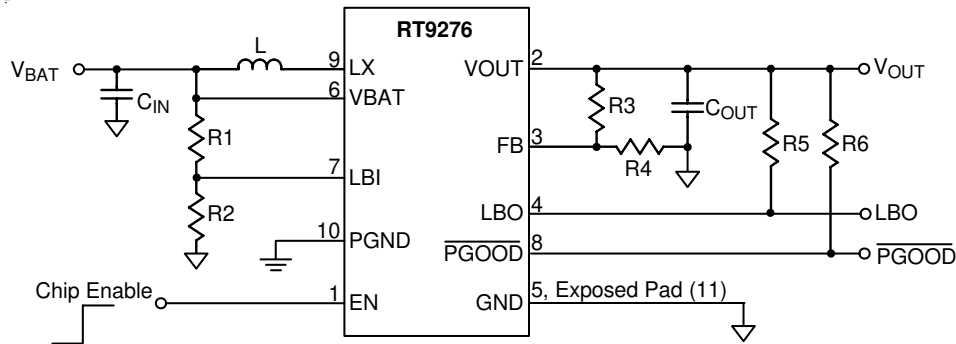

Figure 1. Adjustable Output Voltage Boost Converter with Voltage Detector

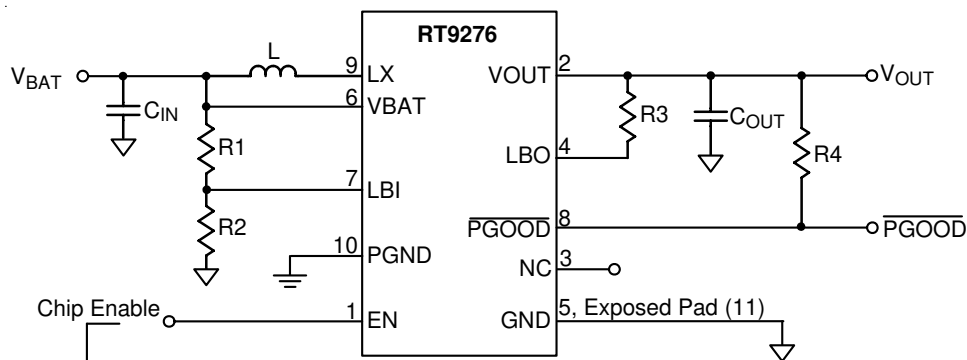

Figure 2. Fixed Output Voltage Boost Converter with Voltage Detector

Functional Pin Description

Pin No.	Pin Name	Pin Function
1	EN	Chip Enable (Active High).
2	VOUT	Boost Output.
3	FB / NC	Feedback Input for Adjustable Output Voltage Version / No Internal Connection for Fixed Output Voltage Version.
4	LBO	Voltage Detector Output.
5	GND	Ground.
6	VBAT	Battery Supply Input.
7	LBI	Voltage Detector Input.
8	PGOOD	Power Good Indicator.
9	LX	Switching Node. Connect this pin to an inductor.
10	PGND	Power Ground.
11 (Exposed Pad)	GND	Ground. The exposed pad must be soldered to a large PCB and connected to GND for maximum power dissipation.

**Function Block Diagram**

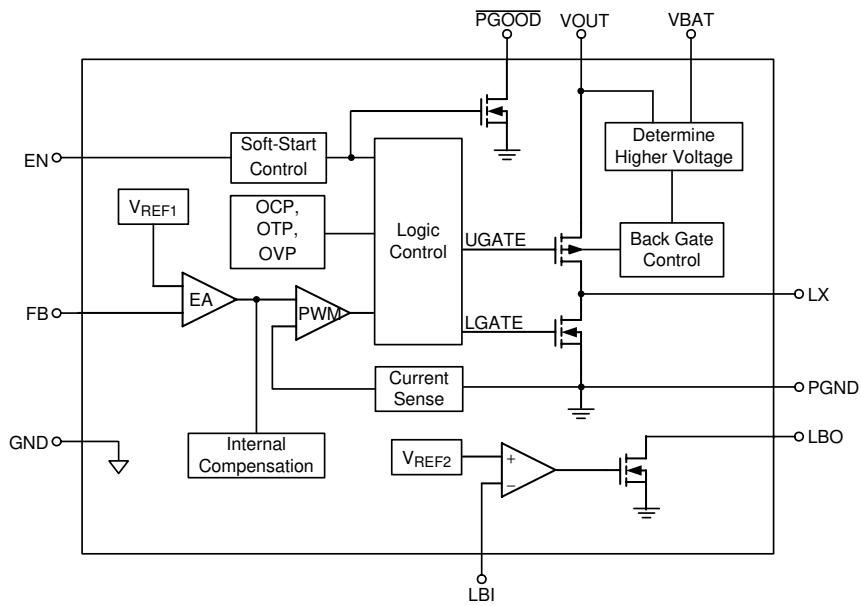

Figure 3. Adjustable Voltage Regulator

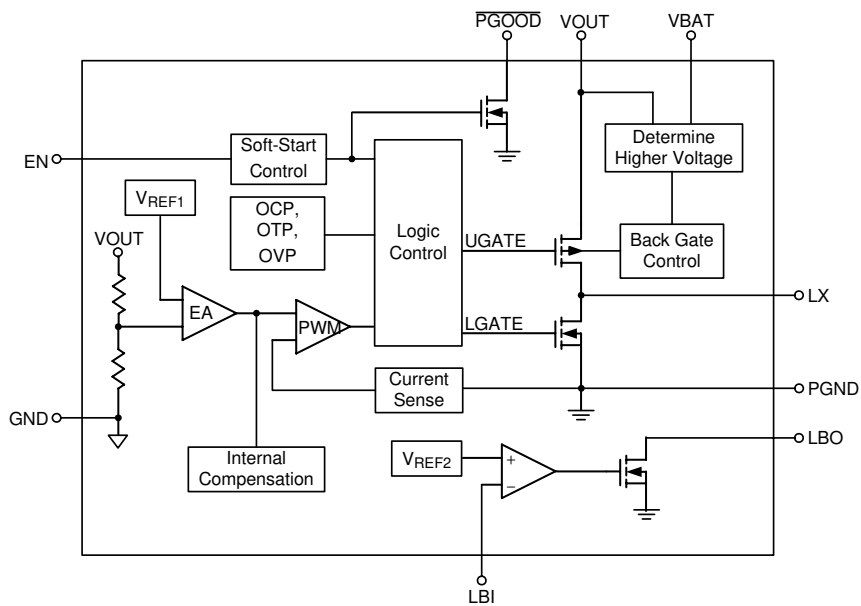

Figure 4. Fixed Voltage Regulator

## Absolute Maximum Ratings (Note 1)

- Supply Input Voltage,  $V_{BAT}$  ----- -0.3V to 6V
- Boost Output Voltage,  $V_{OUT}$  ----- -0.3V to 6.5V
- Switch Output Voltage, LX ----- -0.3V to 6.5V
- <10ns ----- -2V to 7.5V
- Digital Input Voltage, EN, LBI ----- -0.3V to 6V
- Digital Output Voltage, LBO,  $\overline{PGOOD}$  ----- -0.3V to 6V
- Others Pin ----- -0.3V to 6V
- Power Dissipation,  $P_D @ T_A = 25^\circ C$
- WDFN-10L 3x3 ----- 1.429W
- Package Thermal Resistance (Note 2)
- WDFN-10L 3x3,  $\theta_{JA}$  -----  $70^\circ C/W$
- WDFN-10L 3x3,  $\theta_{JC}$  -----  $8.2^\circ C/W$
- Junction Temperature Range -----  $150^\circ C$
- Lead Temperature (Soldering, 10 sec.) -----  $260^\circ C$
- Storage Temperature Range -----  $-65^\circ C$  to  $150^\circ C$
- ESD Susceptibility (Note 3)
- HBM (Human Body Mode) ----- 2kV
- MM (Machine Mode) ----- 200V

## Recommended Operating Conditions (Note 4)

- Supply Input Voltage Range,  $V_{BAT}$  ----- 1.2V to 5V
- Junction Temperature Range -----  $-40^\circ C$  to  $125^\circ C$
- Ambient Temperature Range -----  $-40^\circ C$  to  $85^\circ C$

## Electrical Characteristics

( $V_{BAT} \geq 2.5V$  or  $V_{BAT} = V_{OUT} + 0.7V$ ,  $V_{EN} = V_{BAT}$ ,  $C_{IN} = 10\mu F$ ,  $C_{OUT} = 22\mu F$ ,  $T_A = 25^\circ C$ , unless otherwise specified)

Parameter	Symbol	Test Conditions	Min	Typ	Max	Unit
Pre-charge Current	$I_{Pre-chg}$	$V_{IN} = 5V$	--	100	--	mA
<b>DC/DC Stage</b>						
Minimum Start-Up Input Voltage	$V_{BAT}$	$I_{LOAD} = 1mA$	--	1.2	--	V
Input Voltage Range After Start-Up	$V_{BAT}$		0.8	--	5	V
Output Voltage Range	$V_{OUT}$		--	--	5	V
Feedback Reference Voltage	$V_{FB}$	For Adjustable Output Voltage	0.49	0.5	0.51	V
Output Voltage Accuracy	$\Delta V_{OUT}$	For Fixed Output Voltage	-3	--	3	%
Switching Frequency	$f_{LX}$		0.96	1.2	1.44	MHz
Maximum Duty Cycle	$D_{MAX}$		--	90	--	%
Non-Switching Quiescent Current	$I_{Q,NS}$	No Switching	--	100	--	$\mu A$
Shutdown Current	$I_{SHDN}$	$V_{EN} = 0$ , $V_{BAT} = 1.2V$	--	2	5	$\mu A$

Parameter	Symbol	Test Conditions	Min	Typ	Max	Unit	
<b>Protection</b>							
Over-Temperature Protection	T <sub>OTP</sub>		--	170	--	°C	
Over-Temperature Hysteresis	T <sub>OTP_Hys</sub>		--	40	--	°C	
Over-Current Protection	I <sub>OCP</sub>	V <sub>OUT</sub> = 3.3V	1.6	2	2.4	A	
Over-Voltage Protection	V <sub>OVP</sub>		5.4	--	6	V	
<b>Power MOSFET</b>							
N-MOSFET ON-Resistance	R <sub>DS(ON)_N</sub>	V <sub>OUT</sub> = 3.3V	--	220	--	mΩ	
		V <sub>OUT</sub> = 5V	--	200	--		
P-MOSFET ON-Resistance	R <sub>DS(ON)_P</sub>	V <sub>OUT</sub> = 3.3V	--	260	--	mΩ	
		V <sub>OUT</sub> = 5V	--	240	--		
<b>Enable Control</b>							
EN Threshold Voltage	Logic-High	V <sub>IH</sub>	Rising	0.8	--	--	V
	Logic-Low	V <sub>IL</sub>	Falling	--	--	0.2	
<b>Voltage Detector</b>							
LBI Voltage Threshold	V <sub>LBI_Rising</sub>		0.49	0.5	0.51	V	
LBI Voltage Hysteresis	V <sub>LBI_Hys</sub>		--	10	--	mV	
LBO Output Impedance	R <sub>ON_LBO</sub>	V <sub>LBI</sub> = 0V, V <sub>OUT</sub> = 3.3V	--	15	--	Ω	

**Note 1.** Stresses beyond those listed “Absolute Maximum Ratings” may cause permanent damage to the device. These are stress ratings only, and functional operation of the device at these or any other conditions beyond those indicated in the operational sections of the specifications is not implied. Exposure to absolute maximum rating conditions may affect device reliability.

**Note 2.** θ<sub>JA</sub> is measured at T<sub>A</sub> = 25°C on a high effective thermal conductivity four-layer test board per JEDEC 51-7. θ<sub>JC</sub> is measured at the exposed pad of the package.

**Note 3.** Devices are ESD sensitive. Handling precaution is recommended.

**Note 4.** The device is not guaranteed to function outside its operating conditions.

Typical Operating Characteristics

$C_{IN} = 10\mu F$ ,  $C_{OUT} = 22\mu F$ ,  $L = 4.7\mu H$ , unless otherwise specified.

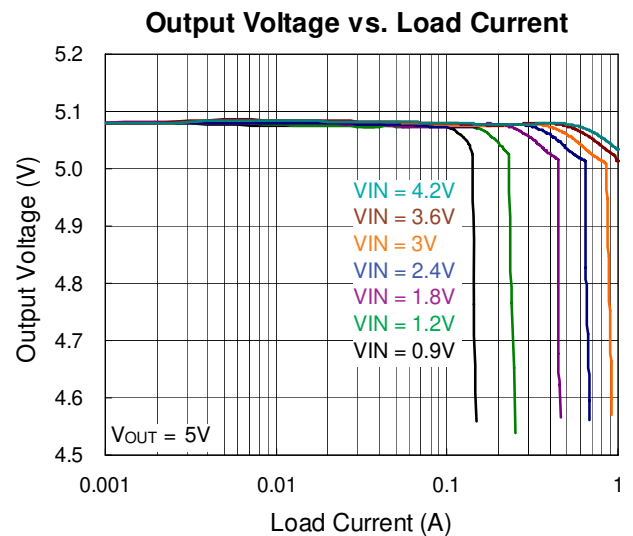
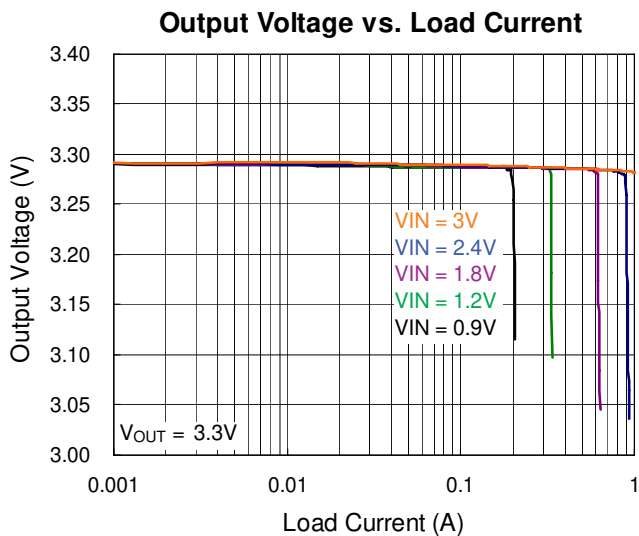
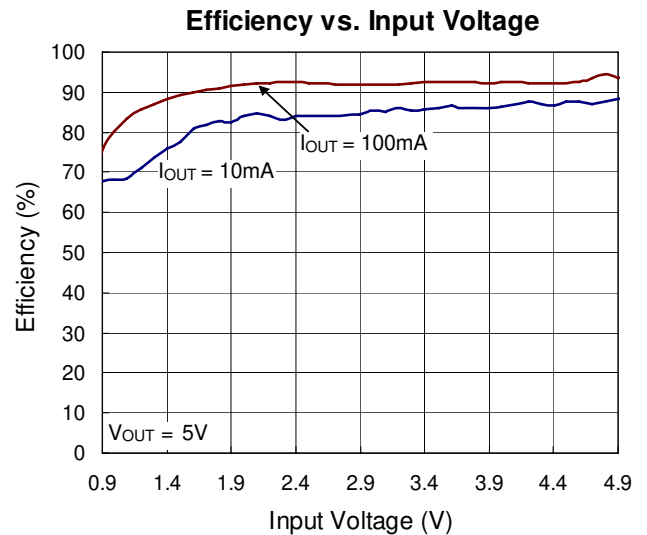
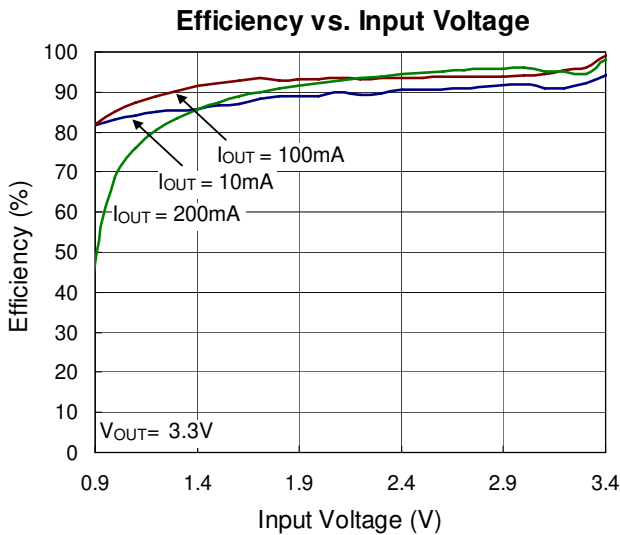
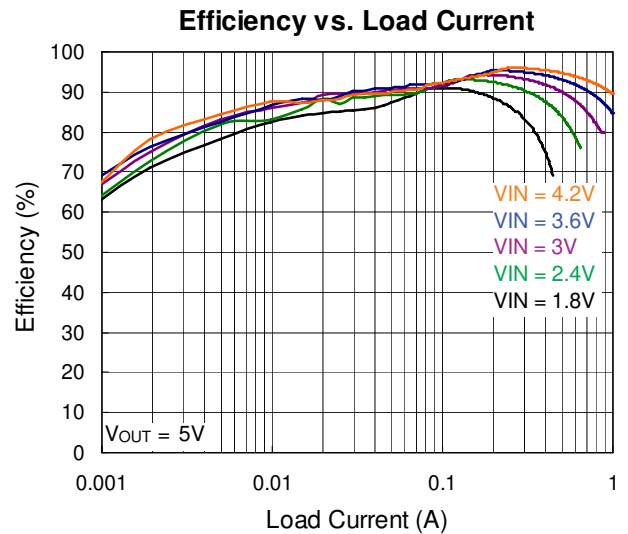
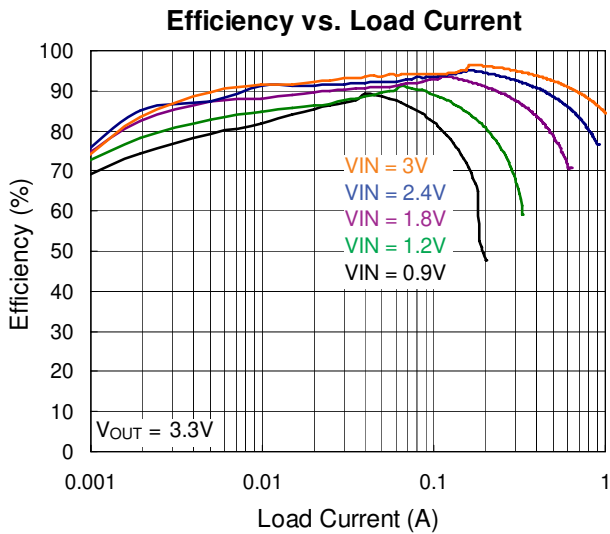

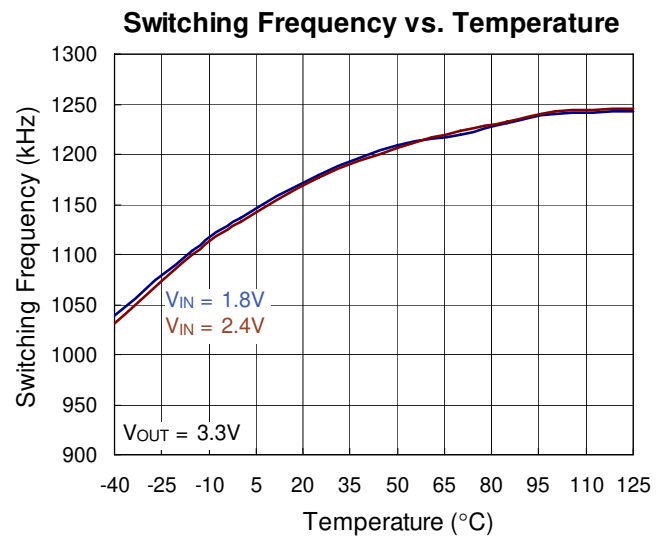
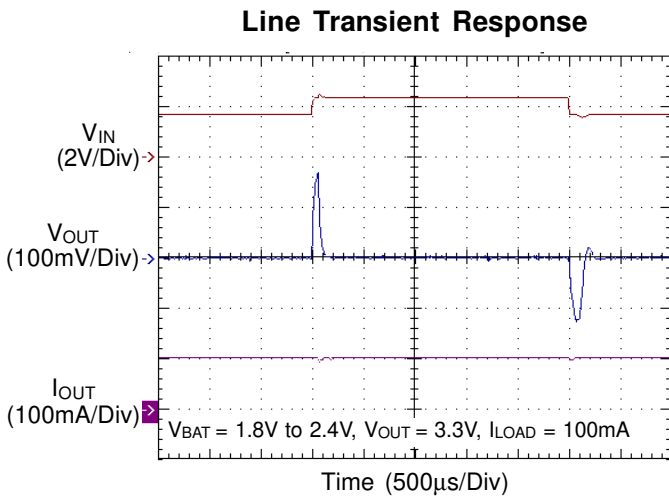
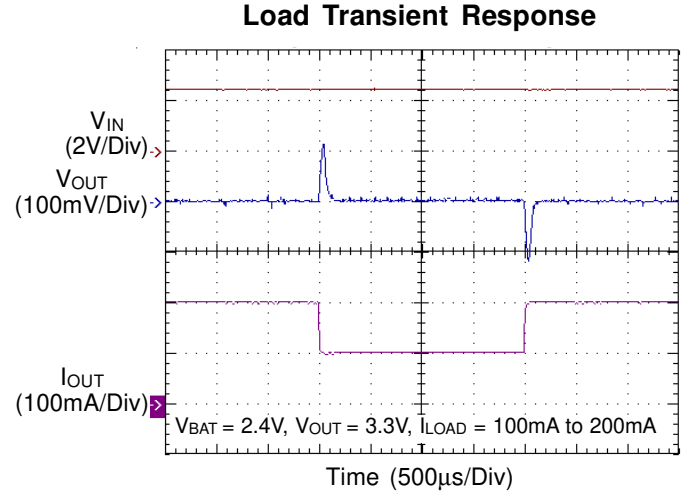
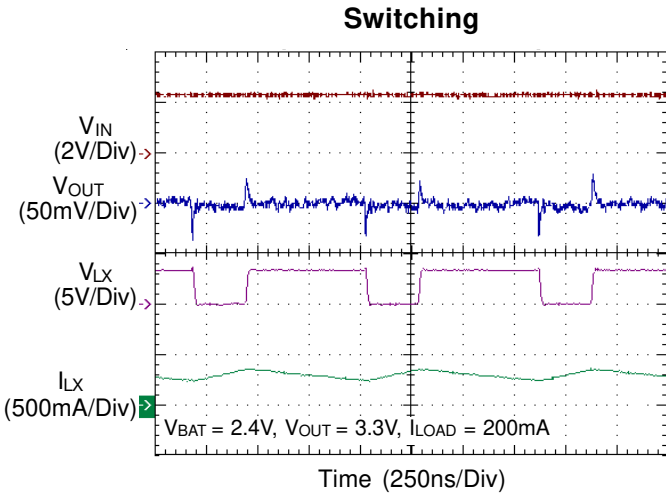
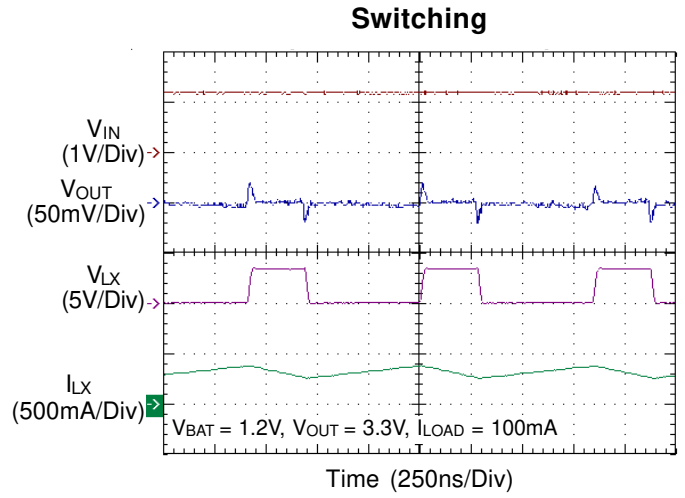
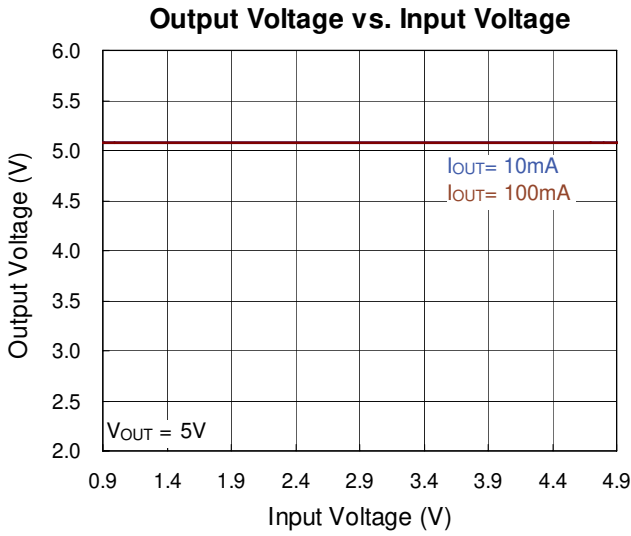

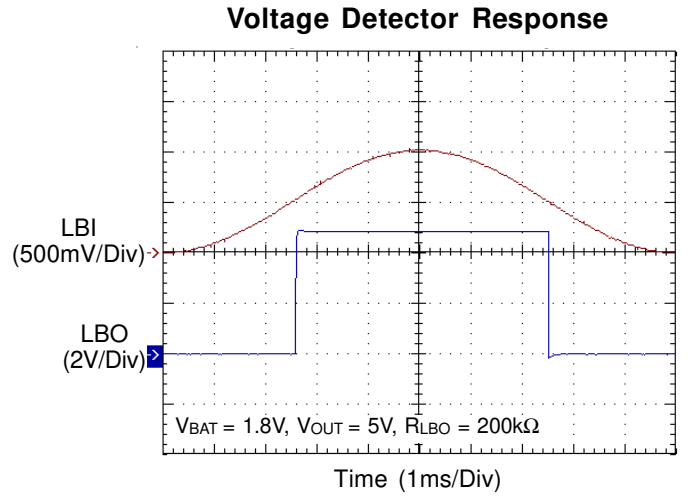
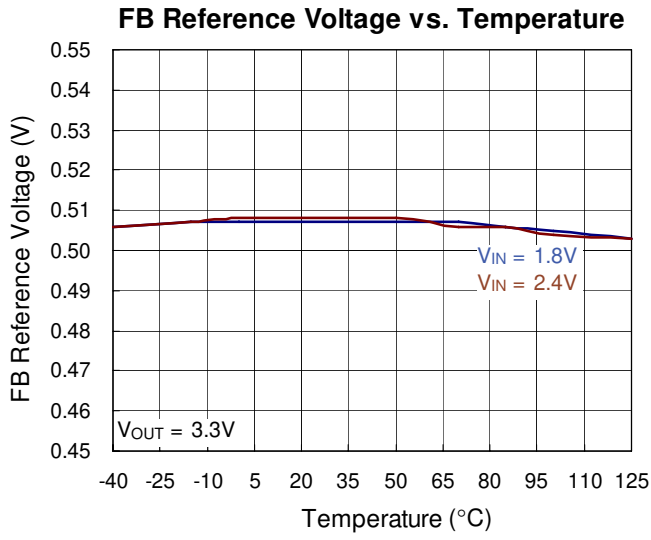



## Application Information

The RT9276 integrates a high efficiency synchronous step-up DC-DC converter and a low battery detector. To fully utilize its advantages, peripheral components should be appropriately selected. The following information provides detailed description of application.

### Inductor Selection

For a better efficiency in high switching frequency converter, the inductor selection has to use a proper core material such as ferrite core to reduce the core loss and choose low ESR wire to reduce copper loss. The most important point is to prevent core saturation when handling the maximum peak current. Using a shielded inductor can minimize radiated noise in sensitive applications. The maximum peak inductor current is the maximum input current plus half of the inductor ripple current. The calculated peak current has to be smaller than the current limitation in the electrical characteristics. A typical setting of the inductor ripple current is 20% to 40% of the maximum input current. If the selection is 40%

$$I_{PK} = I_{IN(MAX)} + \frac{1}{2} I_{RIPPLE} = 1.2 \times I_{IN(MAX)}$$

$$= 1.2 \times \left[ \frac{I_{OUT(MAX)} \times V_{OUT}}{\eta \times V_{BAT(MIN)}} \right]$$

The minimum inductance value is derived from the following equation :

$$L = \frac{\eta \times I_{IN(MIN)}^2 \times [V_{OUT} - V_{BAT(MIN)}]}{0.4 \times I_{OUT(MAX)} \times V_{OUT}^2 \times f_{LX}}$$

Depending on the application, the recommended inductor value is between 2.2μH and 10μH.

### Input Capacitor Selection

For better input bypassing, low-ESR ceramic capacitors are recommended for performance. A 10μF input capacitor is sufficient for most applications. For a lower output power requirement application, this value can be decreased

### Output Capacitor Selection

For lower output voltage ripple, low ESR ceramic capacitors are recommended. The tantalum capacitors can be used as well, but their ESR is bigger than ceramic capacitors. The output voltage ripple consists of two components:

one is the pulsating output ripple current which flows through the ESR, and the other is the capacitive ripple caused by charging and discharging.

$$V_{RIPPLE} = V_{RIPPLE(ESR)} + V_{RIPPLE(C)}$$

$$\cong I_{PEAK} \times R_{ESR} + \frac{I_{PEAK}}{C_{OUT}} \left[ \frac{V_{OUT} - V_{BAT}}{V_{OUT} \times f_{LX}} \right]$$

### Output Voltage Setting

Referring to application circuit (Figure 1), the output voltage of the switching regulator ( $V_{OUT}$ ) can be set with below equation :

$$V_{OUT} = \left( 1 + \frac{R3}{R4} \right) \times V_{FB}$$

where  $V_{FB} = 0.5V$  (typ.)

When the input voltage is larger than output setting voltage 370mV (typ.) the RT9276 will be in pre-charge mode. During pre-charge phase, the synchronous P-MOSFET is turned on until the output capacitor is charged to a value close to the input voltage minus 0.2V. Then the converter is followed by PWM operation. The adaptive pre-charge current increases linearly to overcome the loading current in the pre-charge phase. If the loading current is larger than pre-charge current, the RT9276 will be in pre-charge mode until loading current is removed or reduced.

### Low Battery Voltage Detector

The low battery voltage detector is designed to monitor the battery voltage and to generate an error flag when the battery voltage drops below a user-set threshold voltage. The function is active only when the device is enabled. When the device is disabled, the LBO pin is in high impedance. The LBI threshold voltage is 0.5V typically, with 10mV hysteresis voltage. If the low-battery detection circuit is not used, the LBI pin should be connected to GND (or to  $V_{BAT}$ ) and the LBO pin can be left unconnected. Do not let the LBI pin floating.

### Thermal Considerations

For continuous operation, do not exceed absolute maximum operation junction temperature. The maximum power dissipation depends on the thermal resistance of IC package, PCB layout, the rate of surroundings airflow and temperature difference between junction to ambient.

The maximum power dissipation can be calculated by following formula :

$$P_{D(MAX)} = (T_{J(MAX)} - T_A) / \theta_{JA}$$

where  $T_{J(MAX)}$  is the maximum operation junction temperature,  $T_A$  is the ambient temperature and the  $\theta_{JA}$  is the junction to ambient thermal resistance.

For recommended operating conditions specification, the maximum junction temperature is 125°C. The junction to ambient thermal resistance  $\theta_{JA}$  is layout dependent. For WDFN-10L 3x3 package, the thermal resistance  $\theta_{JA}$  is 70°C/W on a standard JEDEC 51-7 four-layer thermal test board. The maximum power dissipation at  $T_A = 25^\circ\text{C}$  can be calculated by the following formula :

$$P_{D(MAX)} = (125^\circ\text{C} - 25^\circ\text{C}) / (70^\circ\text{C/W}) = 1.429\text{W for WDFN-10L 3x3 packages}$$

The maximum power dissipation depends on operating ambient temperature for fixed  $T_{J(MAX)}$  and thermal resistance  $\theta_{JA}$ . The Figure 5 of derating curves allows the designer to see the effect of rising ambient temperature on the maximum power dissipation.

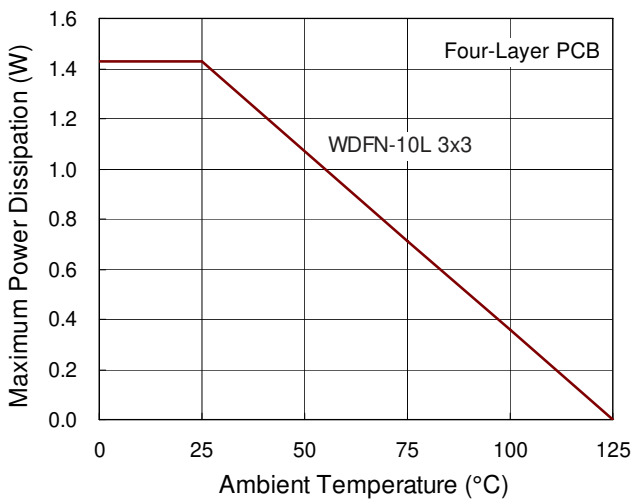

Figure 5. Derating Curve of Maximum Power Dissipation

## Layout Consideration

For best performance of the RT9276, the following layout guidelines must be strictly followed :

- ▶ Input and Output capacitors should be placed close to the IC and connected to ground plane to reduce noise coupling.
- ▶ The GND and Exposed Pad should be connected to a strong ground plane for heat sinking and noise protection.
- ▶ Keep the main current traces as short and wide as possible.
- ▶ Place the feedback components as close as possible to the IC and keep away from the noisy devices.

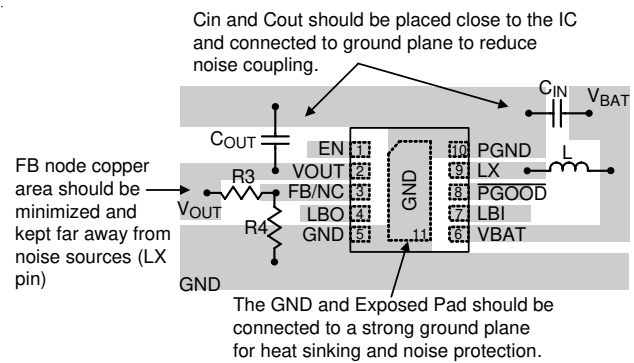
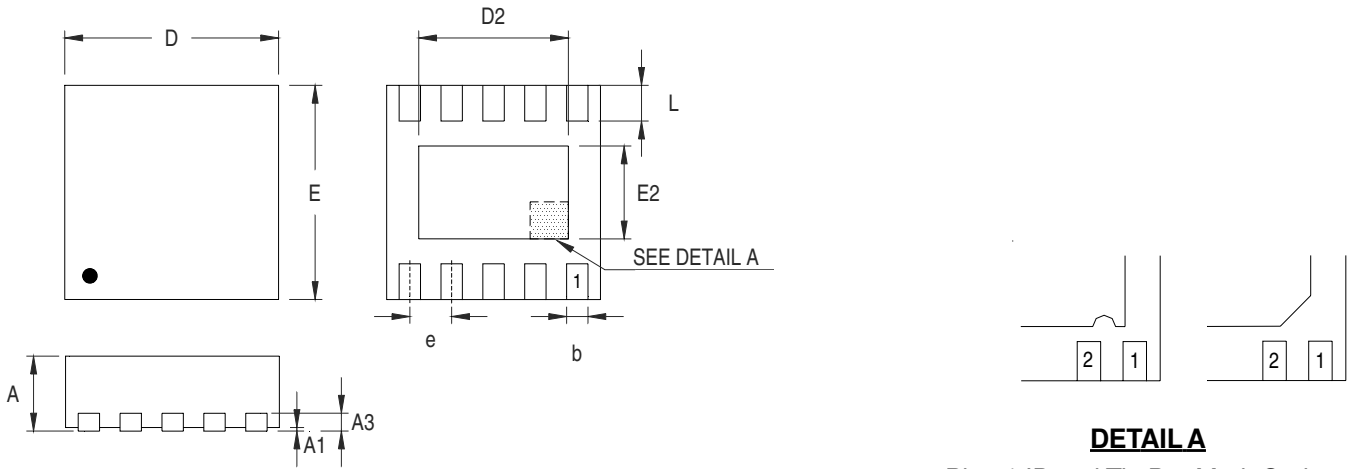

Figure 6. PCB Layout Guide

**Outline Dimension**



**DETAIL A**

Pin #1 ID and Tie Bar Mark Options

Note : The configuration of the Pin #1 identifier is optional, but must be located within the zone indicated.

Symbol	Dimensions In Millimeters		Dimensions In Inches	
	Min	Max	Min	Max
A	0.700	0.800	0.028	0.031
A1	0.000	0.050	0.000	0.002
A3	0.175	0.250	0.007	0.010
b	0.180	0.300	0.007	0.012
D	2.950	3.050	0.116	0.120
D2	2.300	2.650	0.091	0.104
E	2.950	3.050	0.116	0.120
E2	1.500	1.750	0.059	0.069
e	0.500		0.020	
L	0.350	0.450	0.014	0.018

**W-Type 10L DFN 3x3 Package**

**Richtek Technology Corporation**

5F, No. 20, Taiyuen Street, Chupei City  
Hsinchu, Taiwan, R.O.C.  
Tel: (8863)5526789

Richtek products are sold by description only. Richtek reserves the right to change the circuitry and/or specifications without notice at any time. Customers should obtain the latest relevant information and data sheets before placing orders and should verify that such information is current and complete. Richtek cannot assume responsibility for use of any circuitry other than circuitry entirely embodied in a Richtek product. Information furnished by Richtek is believed to be accurate and reliable. However, no responsibility is assumed by Richtek or its subsidiaries for its use; nor for any infringements of patents or other rights of third parties which may result from its use. No license is granted by implication or otherwise under any patent or patent rights of Richtek or its subsidiaries.