

THIS DRAWING IS UNPUBLISHED. RELEASED FOR PUBLICATION 20
 © COPYRIGHT 20 BY - ALL RIGHTS RESERVED.

REVISIONS					
P	LTR	DESCRIPTION	DATE	DWN	APVD
C		REVISED PER ECO-12-010406	04JUN2012	DLD	WEM
CI		REVISED PER ECO-14-004807	28MAR2014	DLD	WEM

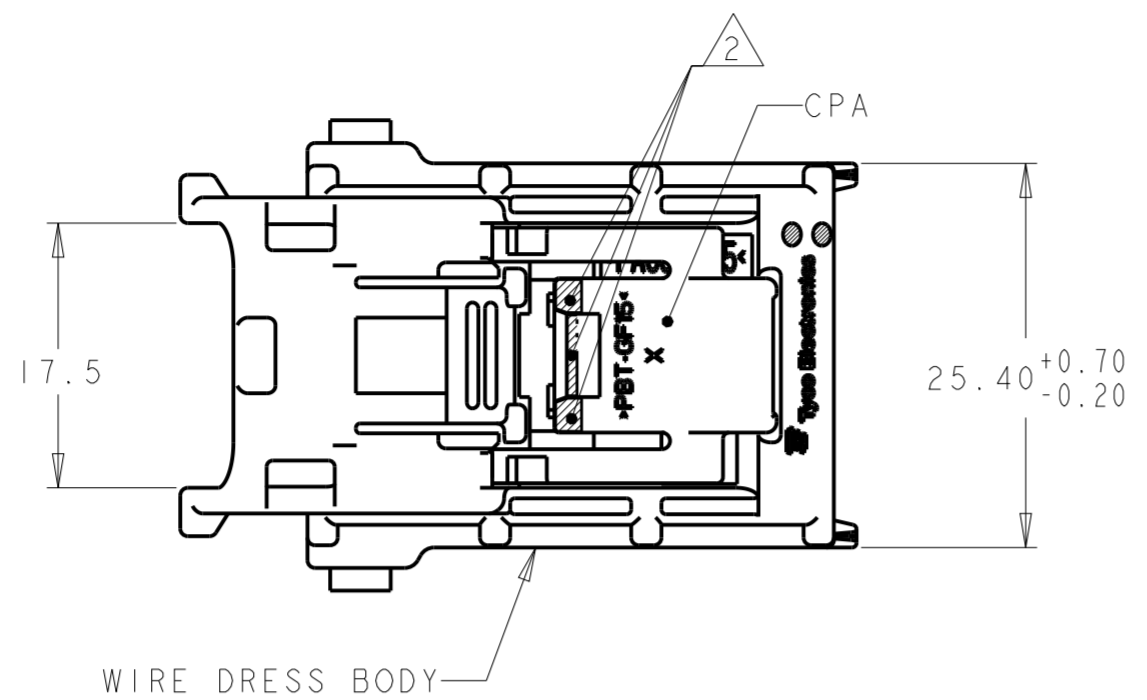

- ① MATERIAL:
 WIRE DRESS BODY - NYLON 6/6, 35% GLASS-FILLED, BLACK
 CPA - PBT 15% GLASS FILLED, RED
- ② COLOR STRIPE APPLIED IN THESE AREAS. WAVY OR IRREGULAR SURFACES AND EDGES ALLOWED.
- ③ APPROXIMATE 1.5mm OVAL RAISED 0.2mm TO IDENTIFY COVERS COMPLYING TO REVISION "C" LOCATED IN EITHER AREA OF COMPANY LOGO AS SHOWN.
- ④ PACKAGING QUANTITY - 250 PIECES PER BOX
- ⑤ PACKAGING QUANTITY - 500 PIECES PER BOX

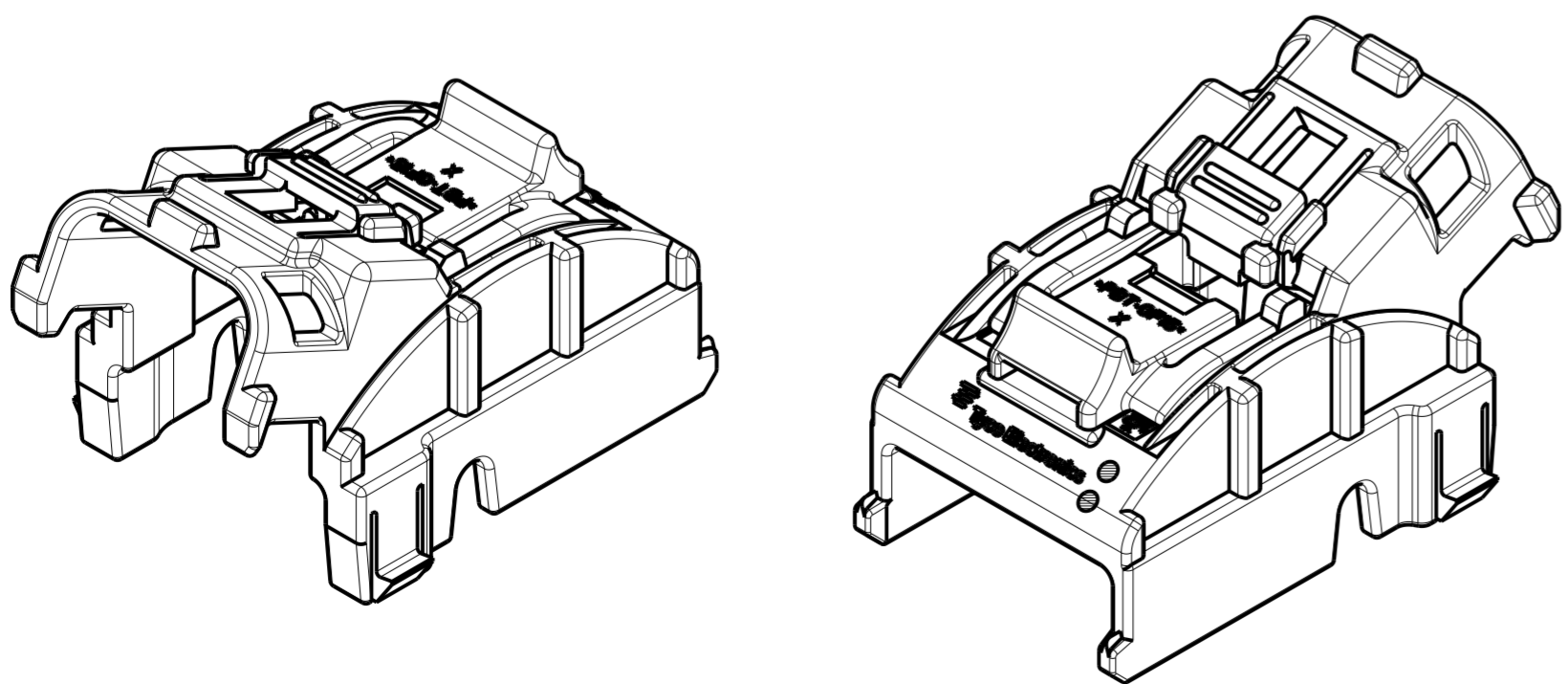
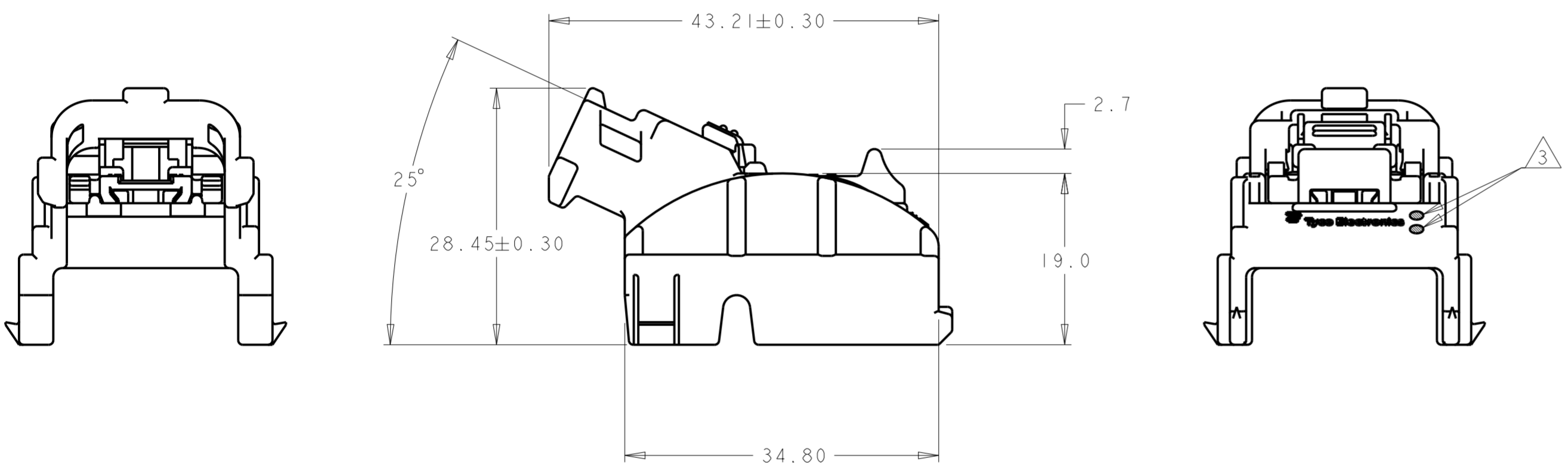

⑤	13503707	WHITE ②	5-776793-2
⑤	19151251	NONE	5-776793-1
④	13503707	WHITE ②	776793-2
④	19151251	NONE	776793-1
	GM P/N	COLOR MARKING	PART NUMBER

THIS DRAWING IS A CONTROLLED DOCUMENT.		DWN RUSTY WORTHINGTON 31OCT2005	TE Connectivity	
		CHK JEREMY PATTERSON 31OCT2005		
		APVD JEREMY PATTERSON 31OCT2005	NAME ASSEMBLY COVER, WIRE DRESS, 24 POSITION PLUG, SDM	
DIMENSIONS: mm		TOLERANCES UNLESS OTHERWISE SPECIFIED:	PRODUCT SPEC	RESTRICTED TO
		0 PLC ± 1 PLC ±0.3 2 PLC ±0.20 3 PLC ± 4 PLC ± ANGLES ±2° FINISH	APPLICATION SPEC	SIZE CAGE CODE DRAWING NO
MATERIAL			WEIGHT	A20779 C-776793
①			CUSTOMER DRAWING	SCALE 2:1 SHEET OF REV C1