



ZCRMZN00100KITG

Crimzon<sup>®</sup> Development  
Board Kit



PUG002601-1207

Product User Guide

---

## Introduction

Zilog's ZCRMZN00100KITG Crimzon<sup>®</sup> Development Board Kit is designed for use as a target with the Crimzon In-Circuit Emulator (ZCRMZNICE01ZEMG). The kit is powered by two 1.5 V AAA batteries (see [Figure 1](#)). The development board can also be powered using an adjustable DC power supply connected to input jack J13. This product user guide helps you to install the batteries supplied with the accessory kit and tells how to verify proper development board operation.

## Kit Contents

The kit contents are listed below:

- One development board with no silicon installed
- Two 1.5 V AAA batteries

## Applying Power to Development Board

Follow the steps below to apply battery power to the development board:

1. Install the two 1.5 V AAA batteries in the battery holder on the bottom of the development board. When installing the batteries, ensure that the batteries are fully seated in the battery holder by rotating each battery after snapping it into place.
2. Set switch SW6 (see [Figure 1](#)) to the BATTERY position.

Follow the steps below to use an adjustable DC power supply to the development board:

1. Set switch SW6 (see [Figure 1](#)) to the EXTERNAL position.
2. Connect the adjustable DC power supply to jack J13 (see [Figure 1](#)).

For more information on using the Crimzon development board accessory kit to develop IR applications, refer to the *Crimzon In-Circuit Emulator User Manual (UM0217)*.

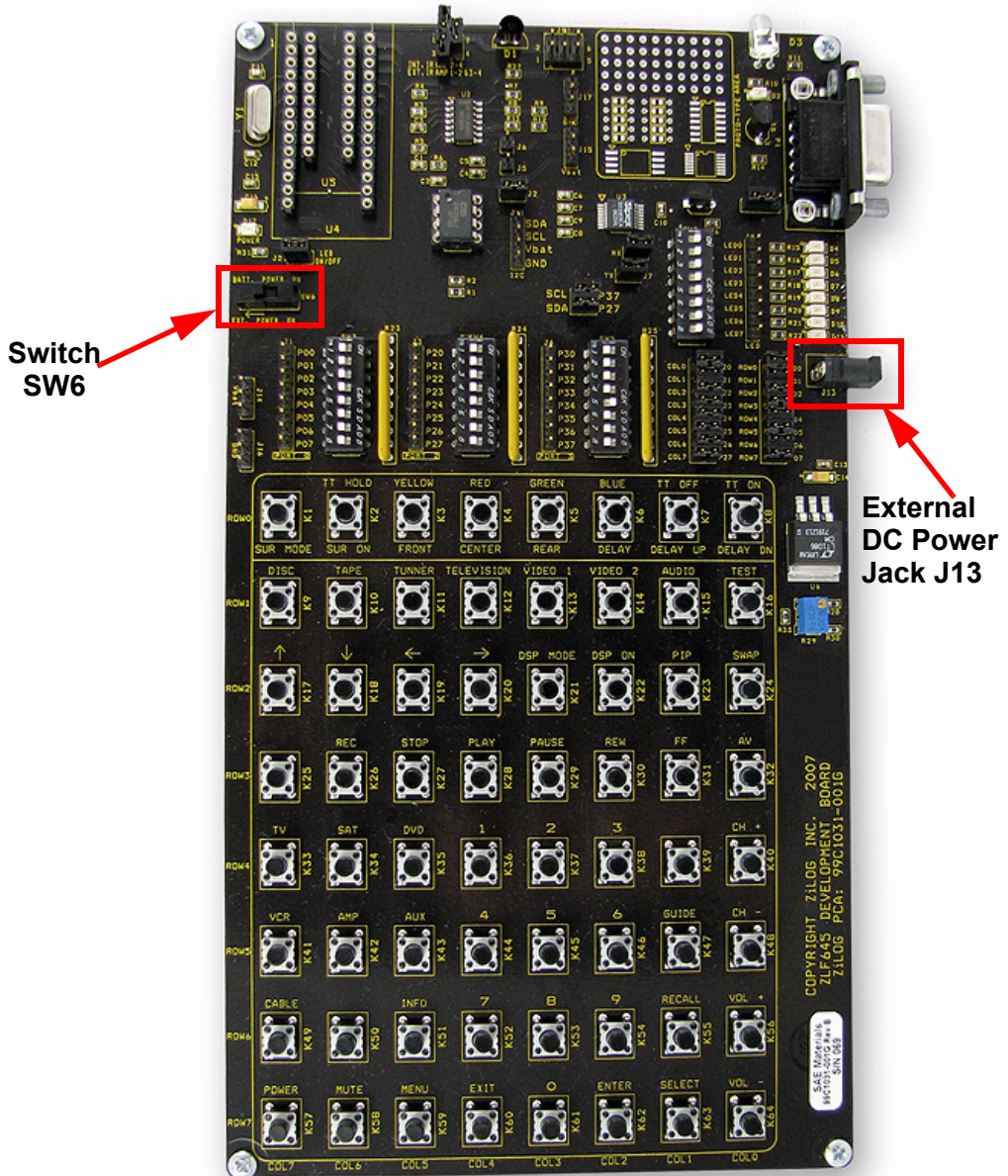

Figure 1. Crimzon® Development Board Kit

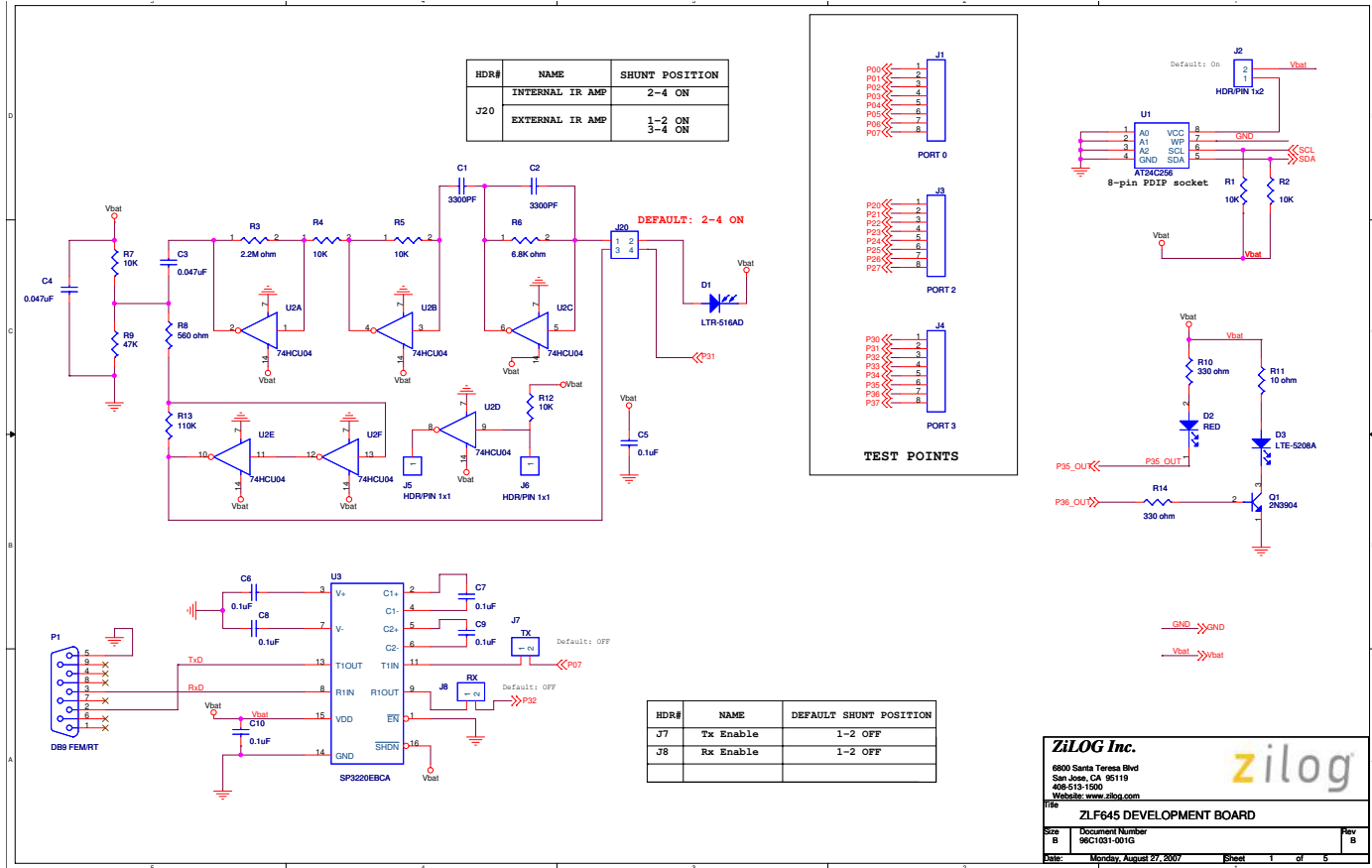

Figure 2. Schematics (1 of 5)

**ZiLOG Inc.**  
 6800 Santa Teresa Blvd  
 San Jose, CA 95119  
 408-513-1500  
 Website: www.zilog.com

File: **ZIF645 DEVELOPMENT BOARD**

Size B	Document Number 96C1031-001G	Rev B
--------	------------------------------	-------

Date: Monday, August 27, 2007 Sheet 1 of 5

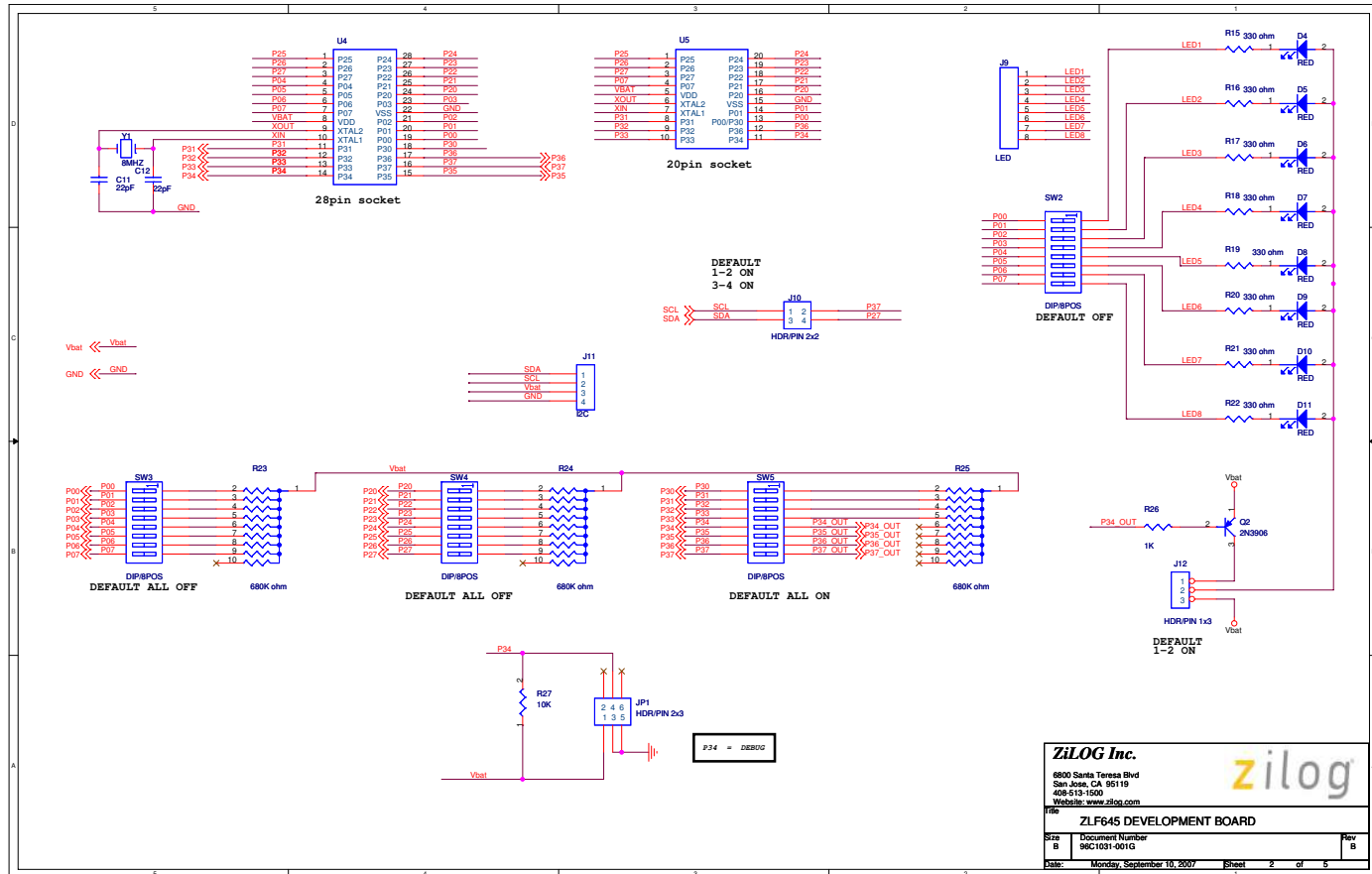

Figure 3. Schematics (2 of 5)

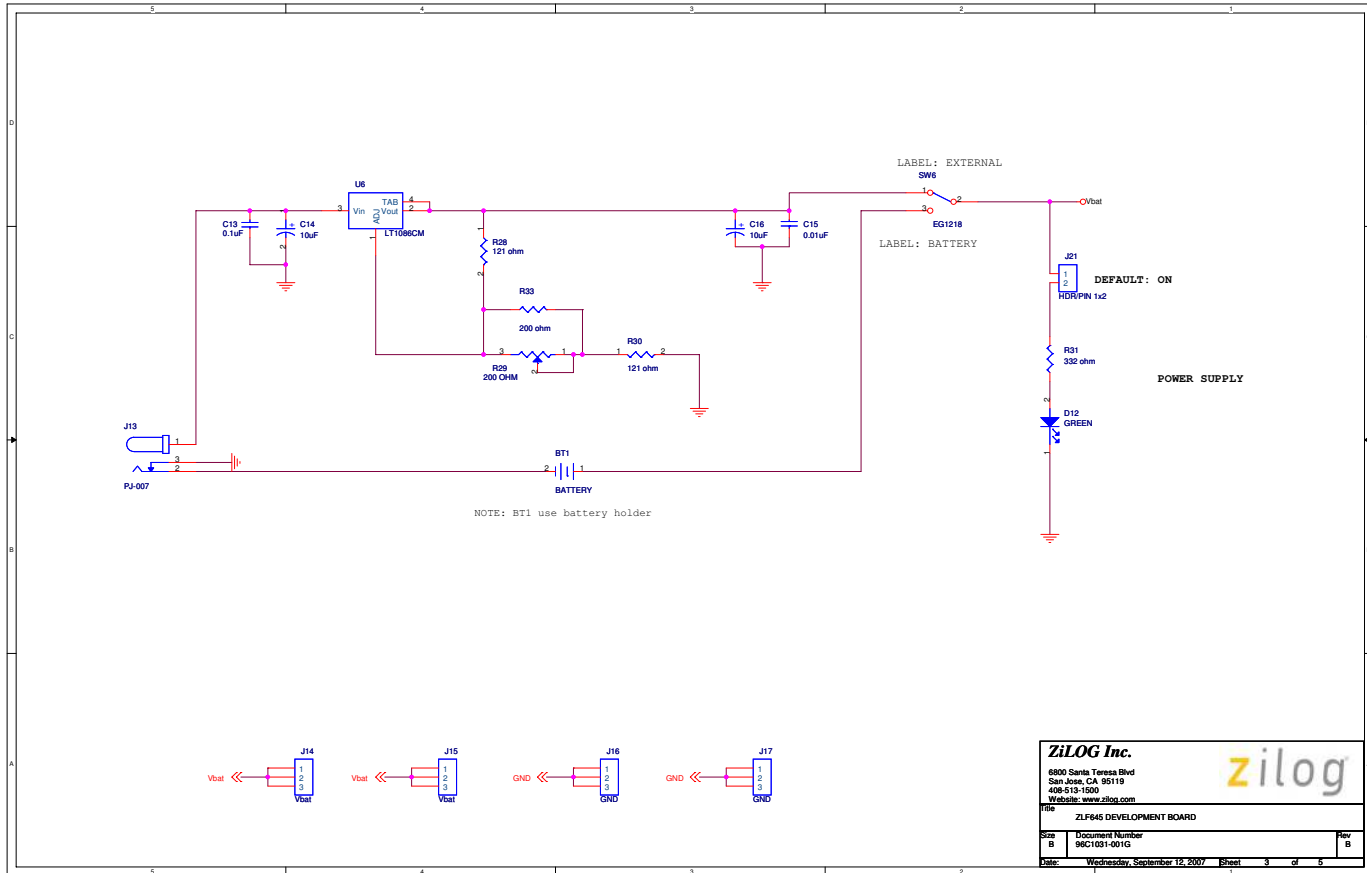

Figure 4. Schematics (3 of 5)

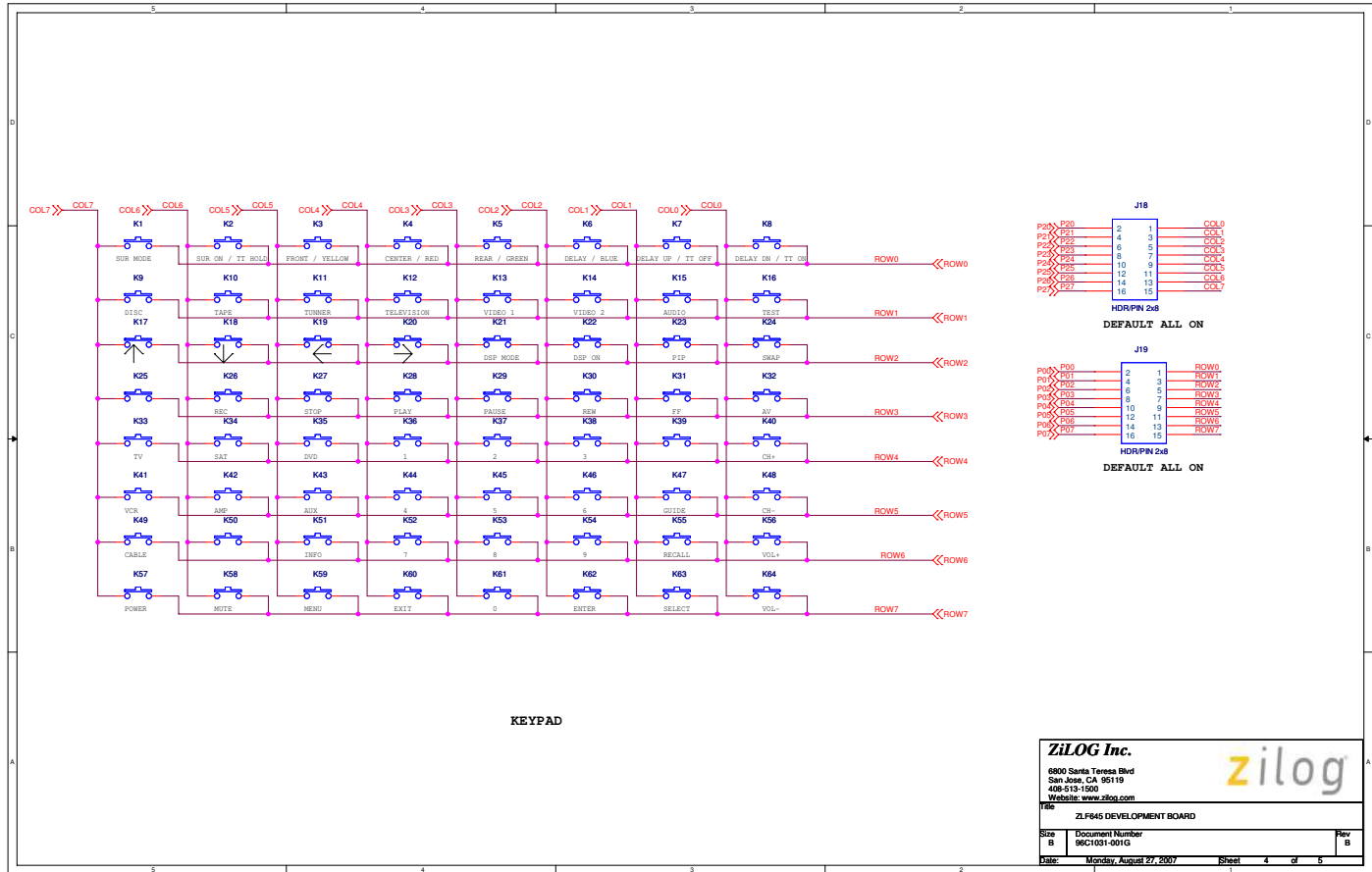

Figure 5. Schematics (4 of 5)

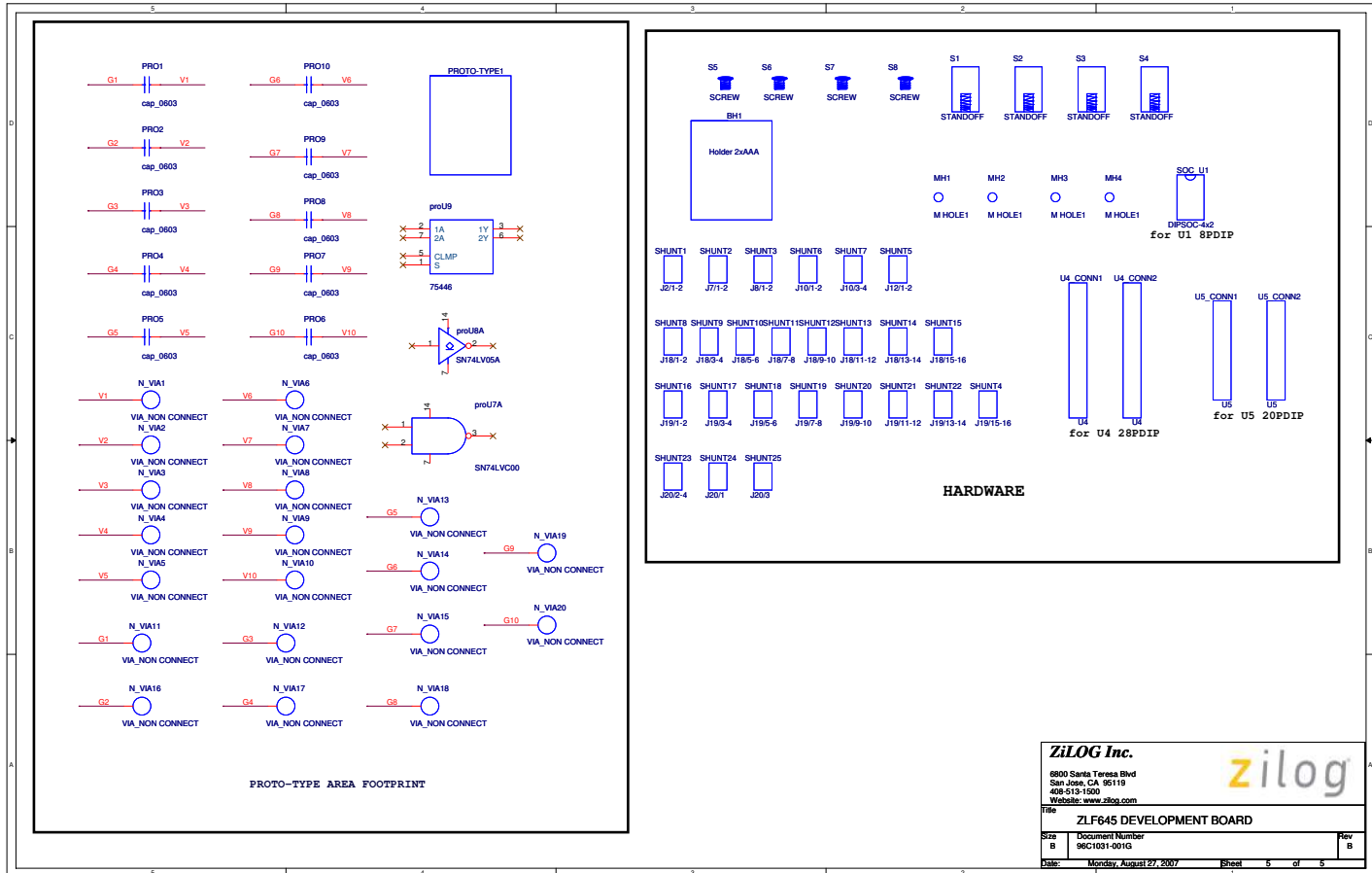

Figure 6. Schematics (5 of 5)



**Warning:** DO NOT USE IN LIFE SUPPORT

### **LIFE SUPPORT POLICY**

ZILOG'S PRODUCTS ARE NOT AUTHORIZED FOR USE AS CRITICAL COMPONENTS IN LIFE SUPPORT DEVICES OR SYSTEMS WITHOUT THE EXPRESS PRIOR WRITTEN APPROVAL OF THE PRESIDENT AND GENERAL COUNSEL OF ZILOG CORPORATION.

### **As used herein**

Life support devices or systems are devices which (a) are intended for surgical implant into the body, or (b) support or sustain life and whose failure to perform when properly used in accordance with instructions for use provided in the labeling can be reasonably expected to result in a significant injury to the user. A critical component is any component in a life support device or system whose failure to perform can be reasonably expected to cause the failure of the life support device or system or to affect its safety or effectiveness.

### **Document Disclaimer**

©2007 by Zilog, Inc. All rights reserved. Information in this publication concerning the devices, applications, or technology described is intended to suggest possible uses and may be superseded. ZILOG, INC. DOES NOT ASSUME LIABILITY FOR OR PROVIDE A REPRESENTATION OF ACCURACY OF THE INFORMATION, DEVICES, OR TECHNOLOGY DESCRIBED IN THIS DOCUMENT. ZILOG ALSO DOES NOT ASSUME LIABILITY FOR INTELLECTUAL PROPERTY INFRINGEMENT RELATED IN ANY MANNER TO USE OF INFORMATION, DEVICES, OR TECHNOLOGY DESCRIBED HEREIN OR OTHERWISE. The information contained within this document has been verified according to the general principles of electrical and mechanical engineering.

Crimzon is a registered trademark of Zilog, Inc. All other product or service names are the property of their respective owners.