

Description

The MK2732-06 is a low-cost, low-jitter, high-performance VCXO and PLL clock synthesizer designed to replace expensive discrete VCXOs and multipliers. The on-chip Voltage Controlled Crystal Oscillator (VCXO) accepts a 0 to 3 V input voltage to cause the output clocks to vary by ± 100 ppm. Using IDT's patented VCXO and analog Phase-Locked Loop (PLL) techniques, the device uses an inexpensive 10 MHz to 14 MHz pullable crystal input to produce up to three output clocks.

IDT manufactures the largest variety of clocks for Set-top boxes and Communications. Consult IDT to eliminate VCXOs, crystals, oscillators and buffers from your board.

Features

- Packaged in 16-pin TSSOP
- Pb (lead) free package
- For xDSL chipsets
- For MPEG2 decoders
- Replaces VCXO and multiplier
- Uses an inexpensive pullable crystal
- On-chip patented VCXO with pull range of 200 ppm (± 100 ppm) minimum
- VCXO tuning voltage of 0 to 3 V
- Zero ppm synthesis error in all clocks
- Full CMOS output swings with 25 mA output drive capability at TTL levels
- Advanced, low-power, sub-micron CMOS process
- 5 V operating voltage for core, ability to run output clocks at 3.3 V or 5 V for easy interface.
- Available in commercial and industrial temperature versions

Block Diagram

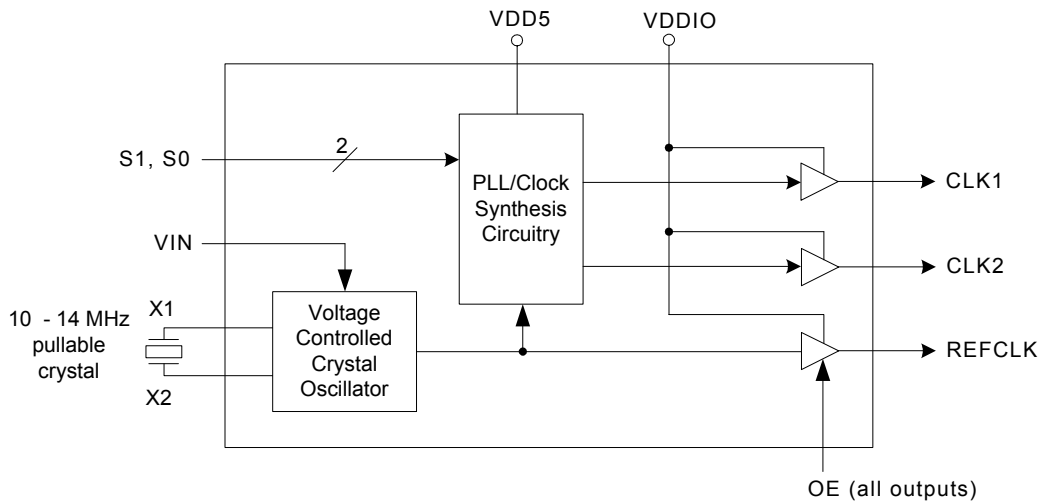

Pin Assignment

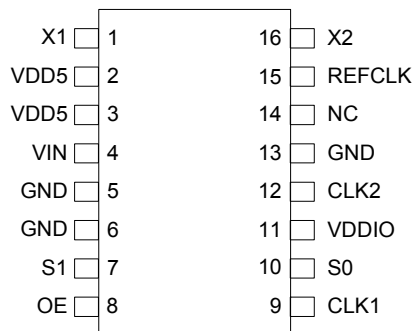

16-pin (173 mil) TSSOP

Clock Select Table

S1	S0	Input	CLK1	CLK2	REFCLK
0	0	13.248	52.992	35.238	OFF
0	M	13.248	13.248	35.238	OFF
0	1	13.248	13.248	35.238	ON
M	0	13.248	52.992	35.238	ON
M	M	13.5	54	27	OFF
M	1	13.5	54	27	ON
1	0	13.5	27	54	ON
1	M	Test mode	—	—	—
1	1	13.5	27	27	ON

0 = connect directly to ground

M=leave unconnected (floating)

1 = connect directly to VDDIO

off=output stopped low

Pin Descriptions

Pin Number	Pin Name	Pin Type	Pin Description
1	X1	XI	Crystal connection. Connect to a pullable crystal of 10 to 14.318 MHz.
2, 3	VDD5	Power	Core VDD. Connect to +5 V.
4	VIN	VI	Voltage input to VCXO. Zero to 3 V signal which controls the frequency of the VCXO.
5, 6, 13	GND	Power	Connect to ground.
7	S1	TI	Select input #1. Selects the outputs per table above. Do not exceed VDDIO.
8	OE	Input	Output Enable. Tri-states outputs when low. Do not exceed VDDIO.
9	CLK1	Output	Clock output #1 per table above. Amplitude = VDDIO.
10	S0	TI	Select input #0. Selects the outputs per table above. Do not exceed VDDIO.
11	VDDIO	Power	Input and output VDD. Connect to 3.3 V or 5 V. Clock amplitude matches this voltage.
12	CLK2	Output	Clock output #2 per table above. Amplitude = VDDIO.
14	NC	—	Nothing connected internally to this pin.
15	REFCLK	Output	Buffered crystal VCXO clock.
16	X2	XO	Crystal connection. Connect to a pullable crystal of 10 to 14 MHz.

Key: TI = tri-level input; VI = analog voltage input; XI, XO = crystal pins

External Component Selection

The MK2732-06 requires a minimum number of external components for proper operation.

Decoupling Capacitor

A decoupling capacitor of 0.01 μF and 0.1 μF must be connected between VDD5 and GND on pins 2, 3 and 5, 6, and VDDIO and GND on pins 11 and 13, as close to the device as possible. For optimum device performance, the decoupling capacitor should be mounted on the component side of the PCB. Avoid the use of vias in the decoupling circuit.

Series Termination Resistor

When the PCB trace between the clock outputs and the loads are over 1 inch, series termination should be used. To series terminate a 50 Ω trace (a commonly used trace impedance) place a 33 Ω resistor in series with the clock line, as close to the clock output pin as possible. The nominal impedance of the clock output is 20 Ω .

Quartz Crystal

The MK2732-06 VCXO function consists of the external crystal and the integrated VCXO oscillator circuit. To assure the best system performance (frequency pull range) and reliability, a crystal device with the recommended parameters (as described in application note MAN05) must be used, and the layout guidelines discussed in the following section must be followed.

The frequency of oscillation of a quartz crystal is determined by its “cut” and by the load capacitors connected to it. The MK2732-06 incorporates on-chip variable load capacitors that “pull” (change) the frequency of the crystal. The crystal specified for use with the MK2732-06 is designed to have zero frequency error when the total of on-chip + stray capacitance is 14 pF.

The external crystal must be connected as close to the chip as possible and should be on the same side of the PCB as the MK2732-06. There should be no vias between the crystal pins and the X1 and X2 device pins. There should be no signal traces underneath or close to the crystal.

Crystal Tuning Load Capacitors

The crystal traces should include pads for small fixed capacitors, one between X1 and ground, and another between X2 and ground. Stuffing of these capacitors on the

PCB is optional. The need for these capacitors is determined at system prototype evaluation, and is influenced by the particular crystal used (manufacture and frequency) and by PCB layout. The typical required capacitor value is 1 to 4 pF.

To determine the need for and value of the crystal adjustment capacitors, you will need a PC board of your final layout, a frequency counter capable of about 1 ppm resolution and accuracy, two power supplies, and some samples of the crystals which you plan to use in production, along with measured initial accuracy for each crystal at the specified crystal load capacitance, C_L .

To determine the value of the crystal capacitors:

1. Connect VDD of the MK2732-06 to 3.3 V. Connect pin 3 of the MK2732-06 to the second power supply. Adjust the voltage on pin 3 to 0V. Measure and record the frequency of the CLK output.
2. Adjust the voltage on pin 3 to 3.3 V. Measure and record the frequency of the same output.

To calculate the centering error:

$$\text{Error} = 10^6 \times \left[\frac{(f_{3.0V} - f_{\text{target}}) + (f_{0V} - f_{\text{target}})}{f_{\text{target}}} \right] - \text{error}_{\text{xtal}}$$

Where:

f_{target} = nominal crystal frequency

$\text{error}_{\text{xtal}}$ = actual initial accuracy (in ppm) of the crystal being measured

If the centering error is less than ± 25 ppm, no adjustment is needed. If the centering error is more than 25 ppm negative, the PC board has excessive stray capacitance and a new PCB layout should be considered to reduce stray capacitance. (Alternately, the crystal may be re-specified to a higher load capacitance. Contact IDT for details.) If the centering error is more than 25 ppm positive, add identical

fixed centering capacitors from each crystal pin to ground. The value for each of these caps (in pF) is given by:

External Capacitor =

$$2 \times (\text{centering error}) / (\text{trim sensitivity})$$

Trim sensitivity is a parameter which can be supplied by your crystal vendor. If you do not know the value, assume it is 30 ppm/pF. After any changes, repeat the measurement to verify that the remaining error is acceptably low (typically less than ± 25 ppm).

Absolute Maximum Ratings

Stresses above the ratings listed below can cause permanent damage to the MK2732-06. These ratings, which are standard values for IDT commercially rated parts, are stress ratings only. Functional operation of the device at these or any other conditions above those indicated in the operational sections of the specifications is not implied. Exposure to absolute maximum rating conditions for extended periods can affect product reliability. Electrical parameters are guaranteed only over the recommended operating temperature range.

Item	Rating
Supply Voltage, VDD	7 V
All Inputs and Outputs	-0.5 V to VDD+0.5 V
Ambient Operating Temperature, Commercial version	0 to +70 °C
Ambient Operating Temperature, Industrial version	-40 to +85 °C
Storage Temperature	-65 to +150 °C
Junction Temperature	125 °C
Soldering Temperature	260 °C

Recommended Operation Conditions

Parameter	Min.	Typ.	Max.	Units
Ambient Operating Temperature	0		+70	°C
Power Supply Voltage (measured in respect to GND)	+4.75		+5.25	V
Reference crystal parameters	Refer to MAN05			

DC Electrical Characteristics

Unless noted otherwise, **VDD5=5.0 V**, **VDDIO=3.3 V**, Ambient temperature 0 to +70° C

Parameter	Symbol	Conditions	Min.	Typ.	Max.	Units
Core Operating Voltage	VDD5		4.75	5.0	5.25	V
Operating Voltage	VDDIO		3.13	3.3	5.25	V
Operating Supply Current	IDD	No load		11		mA
Operating Supply Current	IDDIO	No load		5		mA
Input High Voltage	V _{IH}	X1 pin only	3.5	2.5		V
Input Low Voltage	V _{IL}	X1 pin only		2.5	1.5	V
Input High Voltage	V _{IH}	Binary input, OE	2			V
Input Low Voltage	V _{IL}	Binary input, OE			0.8	V
Input High Voltage	V _{IH}	Trinary inputs, S1, S0	VDD-0.5			V
Input Low Voltage	V _{IL}	Trinary inputs, S1, S0			0.5	V
Output High Voltage	V _{OH}	I _{OH} = -25 mA	2.4			V
Output Low Voltage	V _{OL}	I _{OL} = 25 mA			0.4	V
Output High Voltage	V _{OH}	CMOS Level, I _{OH} = -8 mA	VDD-0.4			V
Short Circuit Current		Each output		±50		mA
Input Capacitance	C _{IN}	S1, S0, OE		7		pF
Frequency Synthesis Error		All clocks			0	ppm
VIN, VCXO Control Voltage			0		3	V

AC Electrical Characteristics

Unless noted otherwise, $V_{DD5}=5.0\text{ V}$, $V_{DDIO}=3.3\text{ V}$, Ambient Temperature 0 to $+70^{\circ}\text{ C}$

Parameter	Symbol	Conditions	Min.	Typ.	Max.	Units
Crystal Input Frequency	F_{IN}		10		14	MHz
Output Rise Time	t_{OR}	0.8 V to 2.0 V			1.5	ns
Output Fall Time	t_{OF}	2.0 V to 0.8 V			1.5	ns
Output Clock Duty Cycle		At $V_{DDIO}/2$	40		60	%
Maximum Absolute Jitter, short term				± 150		ps
Phase Noise, relative to carrier		10 kHz offset		-115		dBc/Hz
Output Pullability		$0\text{ V} \leq V_{IN} \leq 3\text{ V}$	± 100			ppm

Package Outline and Package Dimensions (16-pin TSSOP, 173 Mil. Body)

Package dimensions are kept current with JEDEC Publication No. 95

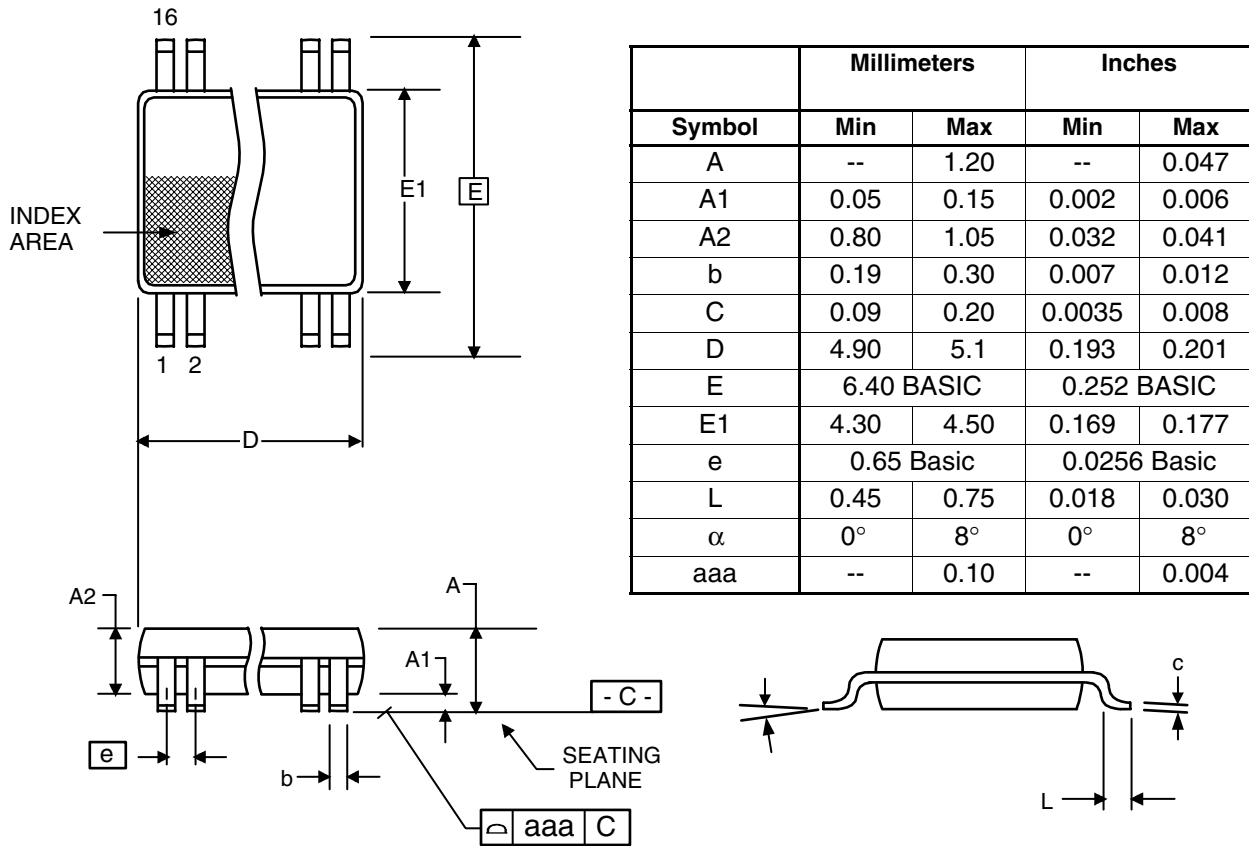

Ordering Information

Part / Order Number	Marking	Shipping Packaging	Package	Temperature
MK2732-06GLF	27326LF	Tubes	16-pin TSSOP	0 to 70° C
MK2732-06GLFTR		Tape and Reel	16-pin TSSOP	0 to 70° C
MK2732-06GILF	27326ILF	Tubes	16-pin TSSOP	-40 to 85° C
MK2732-06GILFTR		Tape and Reel	16-pin TSSOP	-40 to 85° C

While the information presented herein has been checked for both accuracy and reliability, Integrated Device Technology (IDT) assumes no responsibility for either its use or for the infringement of any patents or other rights of third parties, which would result from its use. No other circuits, patents, or licenses are implied. This product is intended for use in normal commercial applications. Any other applications such as those requiring extended temperature range, high reliability, or other extraordinary environmental requirements are not recommended without additional processing by IDT. IDT reserves the right to change any circuitry or specifications without notice. IDT does not authorize or warrant any IDT product for use in life support devices or critical medical instruments.

IMPORTANT NOTICE AND DISCLAIMER

RENESAS ELECTRONICS CORPORATION AND ITS SUBSIDIARIES (“RENESAS”) PROVIDES TECHNICAL SPECIFICATIONS AND RELIABILITY DATA (INCLUDING DATASHEETS), DESIGN RESOURCES (INCLUDING REFERENCE DESIGNS), APPLICATION OR OTHER DESIGN ADVICE, WEB TOOLS, SAFETY INFORMATION, AND OTHER RESOURCES “AS IS” AND WITH ALL FAULTS, AND DISCLAIMS ALL WARRANTIES, EXPRESS OR IMPLIED, INCLUDING, WITHOUT LIMITATION, ANY IMPLIED WARRANTIES OF MERCHANTABILITY, FITNESS FOR A PARTICULAR PURPOSE, OR NON-INFRINGEMENT OF THIRD PARTY INTELLECTUAL PROPERTY RIGHTS.

These resources are intended for developers skilled in the art designing with Renesas products. You are solely responsible for (1) selecting the appropriate products for your application, (2) designing, validating, and testing your application, and (3) ensuring your application meets applicable standards, and any other safety, security, or other requirements. These resources are subject to change without notice. Renesas grants you permission to use these resources only for development of an application that uses Renesas products. Other reproduction or use of these resources is strictly prohibited. No license is granted to any other Renesas intellectual property or to any third party intellectual property. Renesas disclaims responsibility for, and you will fully indemnify Renesas and its representatives against, any claims, damages, costs, losses, or liabilities arising out of your use of these resources. Renesas' products are provided only subject to Renesas' Terms and Conditions of Sale or other applicable terms agreed to in writing. No use of any Renesas resources expands or otherwise alters any applicable warranties or warranty disclaimers for these products.

(Disclaimer Rev.1.0 Mar 2020)

Corporate Headquarters

TOYOSU FORESIA, 3-2-24 Toyosu,
Koto-ku, Tokyo 135-0061, Japan
www.renesas.com

Contact Information

For further information on a product, technology, the most up-to-date version of a document, or your nearest sales office, please visit:
www.renesas.com/contact/

Trademarks

Renesas and the Renesas logo are trademarks of Renesas Electronics Corporation. All trademarks and registered trademarks are the property of their respective owners.