

REVISIONS				
P	LTR	DESCRIPTION	DATE	APPV
E		REVISED PER ECO-16-015028	21OCT2016	SY SY

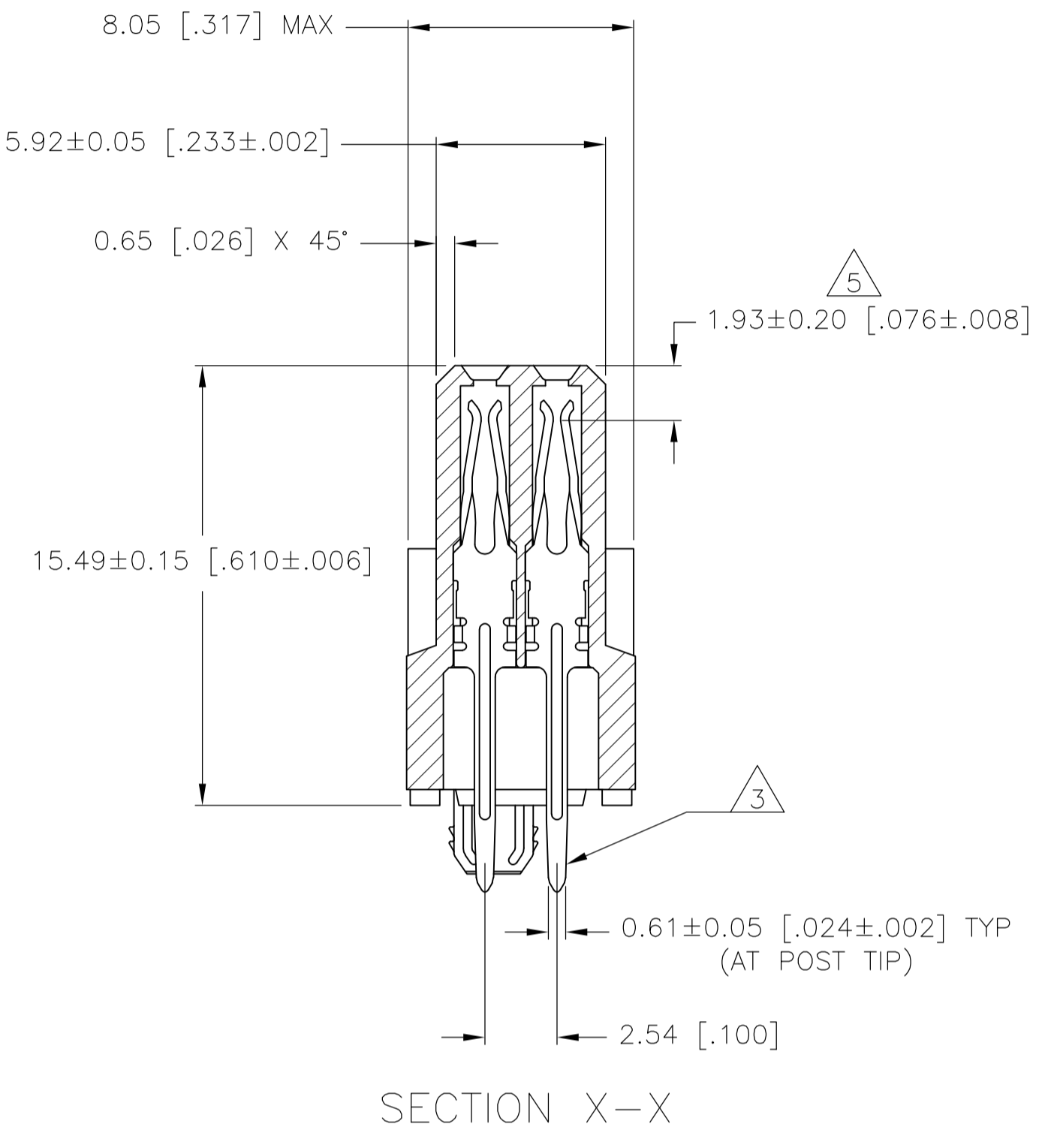

- 1 HOUSING MATERIAL: GLASS FILLED POLYESTER, COLOR: GRAY.
- 2 CONTACT MATERIAL: PHOSPHOR BRONZE
- 3 CONTACT FINISH: 0.00076[.000030] MIN GOLD IN MATING AREA, 0.00254-0.00762[.000100-.000300] TIN-LEAD ON TAILS, ALL OVER 0.00127[.000050] MIN NICKEL.
- 4 PART NUMBER, DATE CODE MARKED ON OPPOSITE SIDE, THIS APPROX AREA.
- 5 CONTACT POINT.
- 6 TO BE G-PAX PACKAGED.
- 7 CURRENT RATING - 2 AMPS MAXIMUM PER CONTACT.
- 8 CONTACT FINISH: 0.00076[.000030] MIN GOLD IN MATING AREA, 0.00254-0.00762[.000100-.000300] MATTE TIN ON TAILS, ALL OVER 0.00127[.000050] MIN NICKEL.
- 9 HOUSING MATERIAL: LCP, COLOR: NATURAL, HIGH TEMP FOR REFLOW PROCESS
- 10 "HT" FOR HIGH TEMP MARK IN APPROX AREA

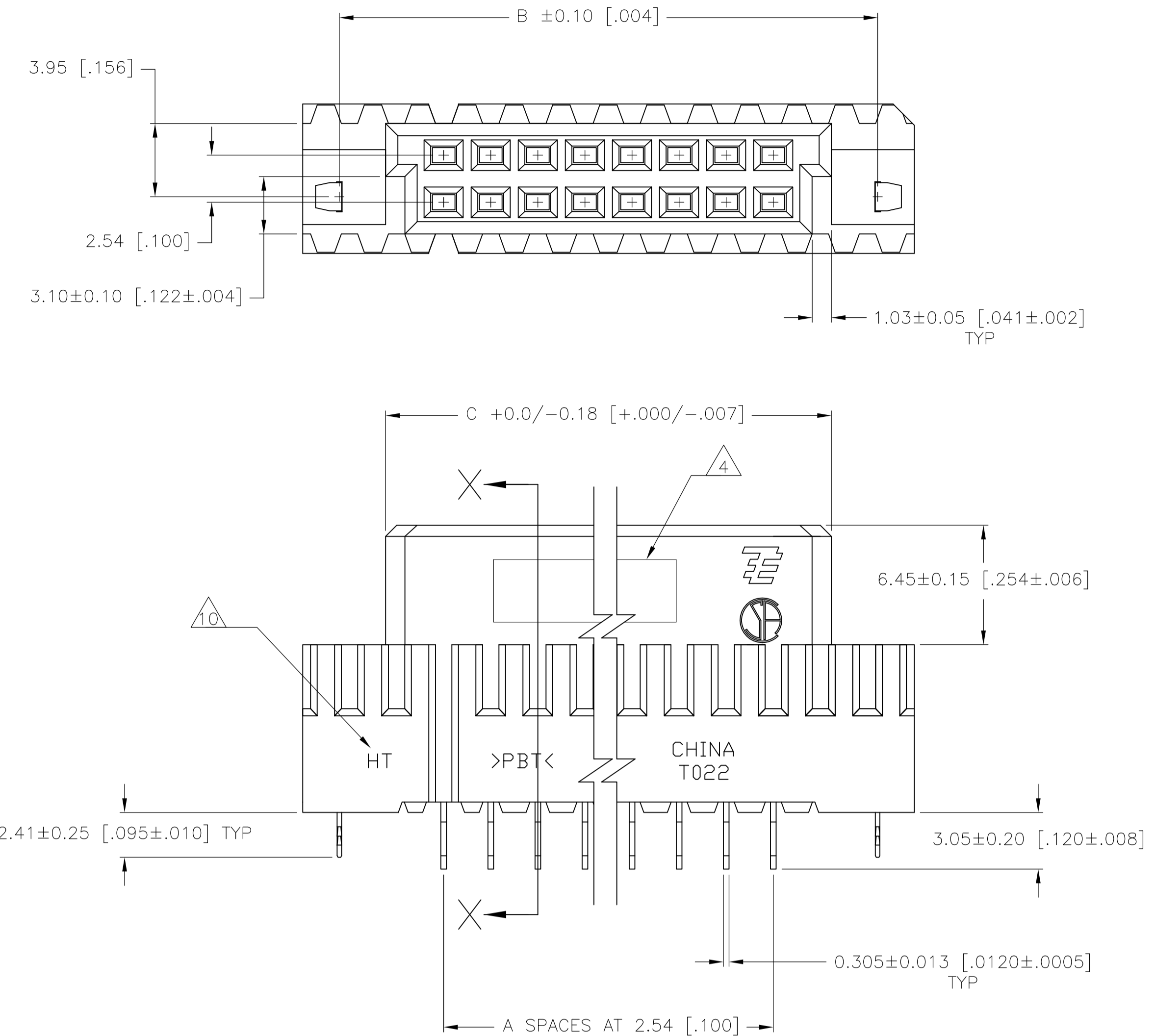
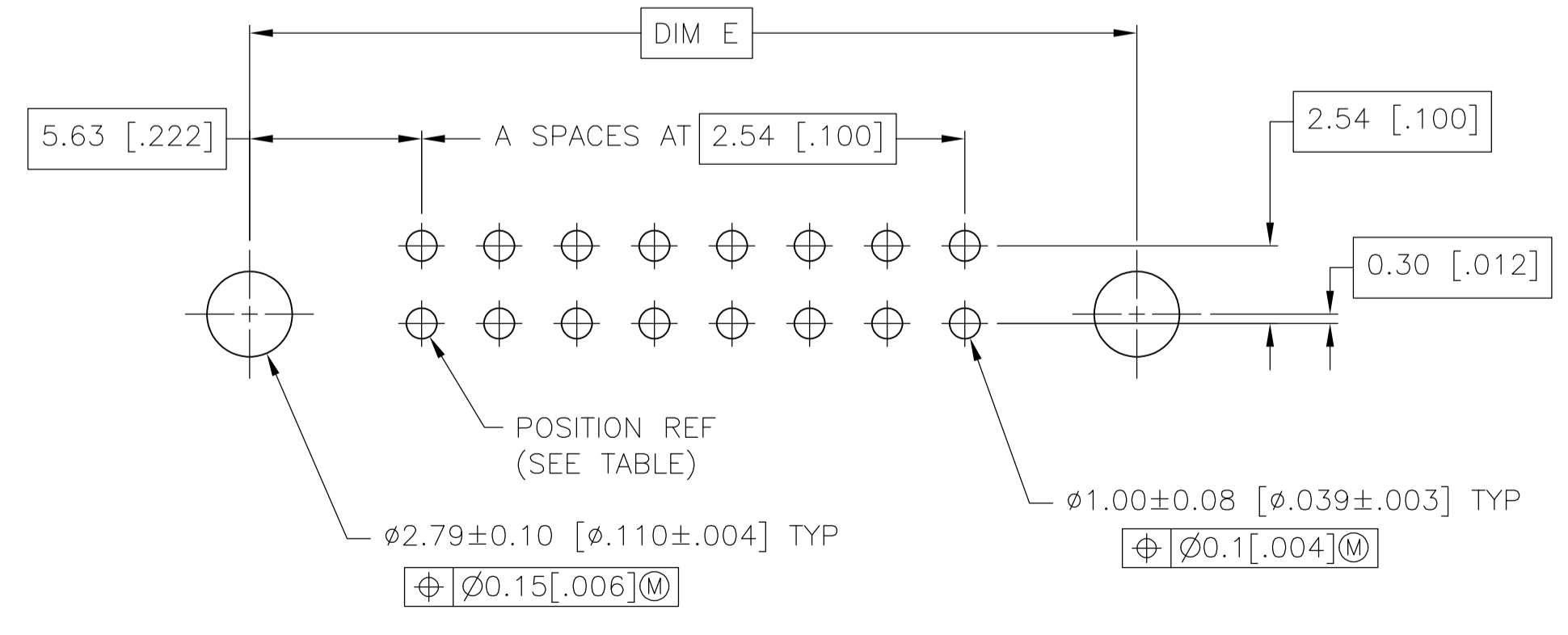
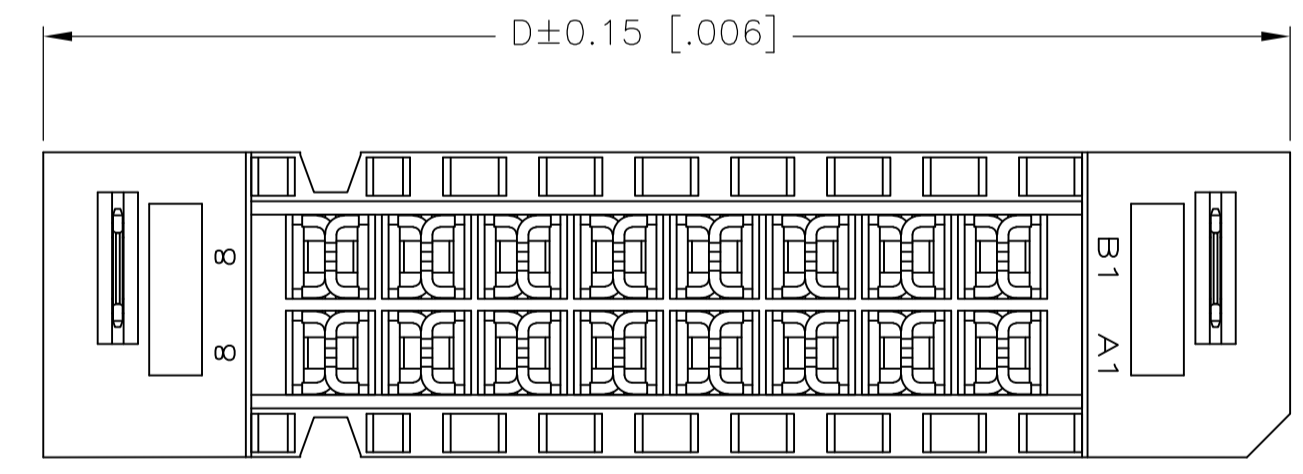

RECOMMENDED PC BOARD LAYOUT

FINISH	POSITION	E	D	C	B	A	NO. OF POSN	PART NUMBER	
9 10	8	B13	41.73 [1.643]	45.59 [1.795]	36.73 [1.446]	41.73 [1.643]	12	26	6-1571436-3
9 10	8	B8	29.03 [1.143]	32.89 [1.295]	24.03 [.946]	29.03 [1.143]	7	16	6-1571436-2
9 10	8	B5	21.41 [.843]	25.27 [.995]	16.41 [.646]	21.41 [.843]	4	10	6-1571436-1
	8	B13	41.73 [1.643]	45.59 [1.795]	36.73 [1.446]	41.73 [1.643]	12	26	5-1571436-3
	8	B8	29.03 [1.143]	32.89 [1.295]	24.03 [.946]	29.03 [1.143]	7	16	5-1571436-2
	8	B5	21.41 [.843]	25.27 [.995]	16.41 [.646]	21.41 [.843]	4	10	5-1571436-1
	3	B13	41.73 [1.643]	45.59 [1.795]	36.73 [1.446]	41.73 [1.643]	12	26	1571436-3
	3	B8	29.03 [1.143]	32.89 [1.295]	24.03 [.946]	29.03 [1.143]	7	16	1571436-2
	3	B5	21.41 [.843]	25.27 [.995]	16.41 [.646]	21.41 [.843]	4	10	1571436-1

THIS DRAWING IS A CONTROLLED DOCUMENT.

DIMENSIONS: mm [INCHES]

TOLERANCES UNLESS OTHERWISE SPECIFIED:

0 PL	± -
1 PL	± -
2 PL	± 0.13 [.005]
3 PL	± -
4 PL	± -

ANGLES: ± -

MATERIAL: 1 2 9

FINISH: SEE TABLE

WEIGHT: 0.000000

SIZE: A1

CAGE CODE: 00779

DRAWING NO: 1571436

RESTRICTED TO: CUSTOMER DRAWING

SCALE: 5:1

SHEET: 1 of 1

REV: E

STE TE Connectivity

RECEPTACLE ASSEMBLY, EUROCARD, TYPE C WITH BOARD LOCKS, SPECIAL PACKAGING