

THIS DRAWING IS UNPUBLISHED. RELEASED FOR PUBLICATION
 © COPYRIGHT - By - ALL RIGHTS RESERVED.

LOC	DIST	REVISIONS			
P	LTR	DESCRIPTION	DATE	DWN	APVD
G	14	G5	REVISED PER ECO-15-006387	27APR2015	NK DR

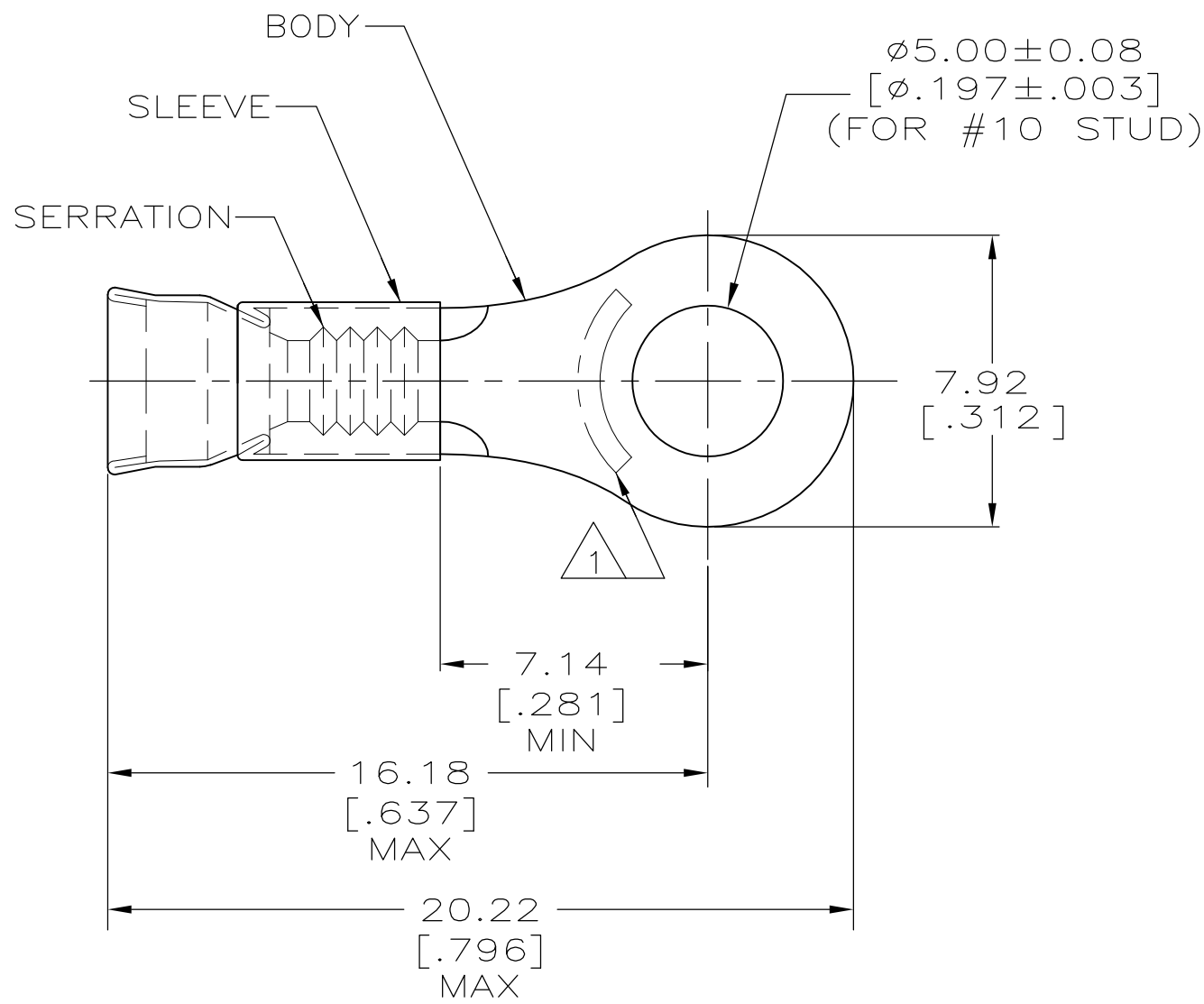

- 1 22-18 STAMP AMP APPROX AS SHOWN
22-16 TERMINALS ARE STAMPED 22-18 IN ACCORDANCE WITH MILITARY SPEC SAE AS7928
COMMERCIAL WIRE RANGE IS 22-16
- 2 WIRE INSUL DIA, 2.67-3.56[.105-.140]
- 3 TONGUE MATL THK, 0.79±0.05[.031±.002]
- 4 PRELIMINARY-NOT FOR PRODUCTION.
- 5 BODY: GOLD PLATE 0.00127[.000050]MIN EXT. THK PER ASTM B488 TYPE 1, CODE C OVER NICKEL FLASH PER SAE AMS QQ-N-290 OVER WOODS, NICKEL FLASH PER ASTM B558.
- 6 CARBON CONTENT ≤.02%

MAX OPERATING TEMP	FINISH	STAMPING	BODY MATERIAL	SLV COLOR	QTY	PACKAGE TYPE	PART NO
649°C [1200°F]	-	AMP 22-18	NICKEL PER ASTM B162	ORANGE	5000	ON TAPE, REEL	1-321898-1
649°C [1200°F]	-	AMP 22-18AL	ALUMEL	GREEN	500	LOOSE PIECE	1-321898-0
260°C [500°F]	5	AMP 22-18	NICKEL PER ASTM B162	ORANGE	1000	LOOSE PIECE	321898-1
649°C [1200°F]	-	AMP 22-18	NICKEL PER ASTM B162	ORANGE	1000	LOOSE PIECE	321898

AMP INCORPORATED CUSTOMER SERVICE SYSTEM		MAX RECOMMENDED OPERATING TEMPERATURE: SEE TABLE	THIS DRAWING IS A CONTROLLED DOCUMENT.		DWN L OLMEDA 100CT94	TE Connectivity NAME: TERMINAL, RING TONGUE, STRATOTHERM, DIAMOND GRIP, WIRE SIZE: 22-16 AWG									
FOR ADDITIONAL PRODUCT INFORMATION OR COPIES OF DRAWINGS AND TECHNICAL DOCUMENTS	PRODUCT INFORMATION CENTER 1-800-522-6752	VOLTAGE RATING: -	DIMENSIONS: mm [INCHES]	TOLERANCES UNLESS OTHERWISE SPECIFIED:	CHK M ELLIS 100CT94				APVD S BORTNER 100CT94	SIZE	CAGE CODE	DRAWING NO	RESTRICTED TO		
FOR APPLICATION TOOLING INFORMATION	TOOLING ASSISTANCE CENTER 1-800-722-1111	CIRCULAR MIL AREA: 0.26mm ² -1.65mm ² [509-3260]			0 PLC ± -	1 PLC ± -	2 PLC ± 0.20[.008]	3 PLC ± -	4 PLC ± -	ANGLES ± -	WEIGHT -	A3	00779	C-321898	-
FOR ORDER ENTRY	1-800-526-5142	STRANDED WIRE	MATERIAL BODY, SEE TABLE SLEEVE, NI SIL PER ASTM B122	FINISH SLV COLOR, SEE TABLE	CUSTOMER DRAWING			SCALE 6:1	SHEET 1 OF 1	REV G5					