

**DESIGNED & DIMENSIONED IN MILLIMETERS
(INCHES FOR REFERENCE ONLY)**

DO NOT SCALE FROM THIS PRINT

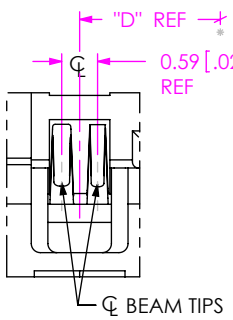

DETAIL 'B' SCALE 8:1

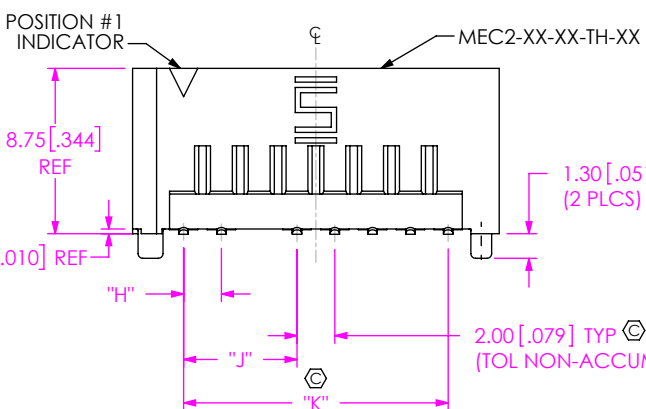
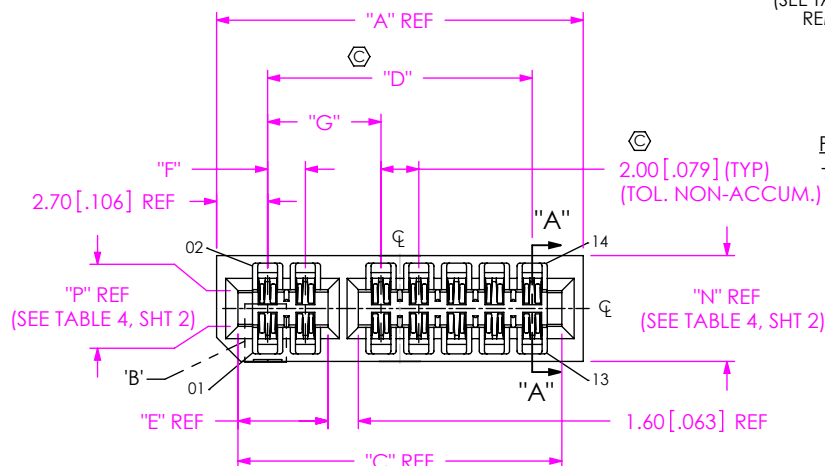
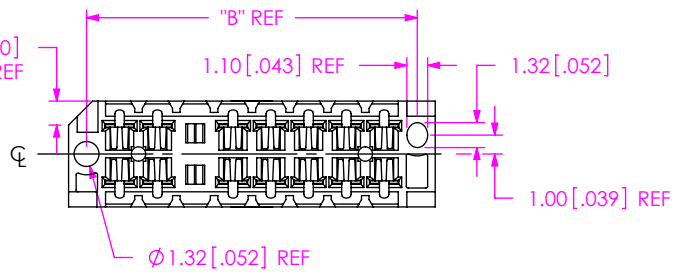

FIG 1

NOTES: 1. (C) REPRESENTS A CRITICAL DIMENSION. (MEC2-08-01-XX-DV-XX SHOWN)
2. BURR ALLOWANCE: 0.04[.0015] MAX.
3. MINIMUM PUSHOUT FORCE: 2.2 NEWTONS [.50LBS.]
4. ALL TAIL TO TAIL DIMENSIONS MEASURED TIP TO TIP.
5. NOTE DELETED.
6. MATING EDGE CARD THICKNESS TOLERANCE NOT TO EXCEED ±10%
7. TUBES ARE STANDARD PACKAGING.
8. ORDERS WILL BE PACKAGED ACCORDING TO THE SAMTEC PACKAGING EFFICIENCY STANDARDS (SPES) FOUND ON WWW.SAMTEC.COM
9. ATTACH LABEL TO EACH REEL

MEC2-XX-XX-X-XXX-XX-X-XX

No OF POSITIONS (PER ROW)
-05, -08, -20, -30, -40, -50
(SEE TABLE 2 FOR POSITION REMOVED TO POLARIZE)

CARD THICKNESS
-01: 1.57mm [.062"] THICK
-02: 2.36mm [.093"] THICK

PLATING SPECIFICATION
-L: 10μ" LIGHT SELECTIVE GOLD IN CONTACT AREA MATTE TIN ON TAIL

ROW SPECIFICATION
-DV: SURFACE MOUNT
-TH1: THROUGH HOLE FOR 1.57mm [.062"] THICK BOARD
□-TH2: THROUGH HOLE FOR 2.36mm [.093"] THICK BOARD
(□ = NOT RELEASED)

PACKAGING (SEE NOTES 8 & 9)
BLANK: TUBES (SEE NOTE 7)
-TR: TAPE & REEL (-05 THRU -30 POS ONLY) AVAILABLE WITH -DV ONLY
-FR: FULL REEL QTY TAPE & REEL (-05 THRU -30 POS ONLY) AVAILABLE WITH -DV ONLY

PICK & PLACE PAD

-K: POLYIMIDE FILM PAD (SEE SHT 2, TABLE 6) AVAILABLE WITH -DV & -T ONLY (-05 THRU -30 POS ONLY)

OPTION

-NP: NON-POLARIZED (-05, -08, -20 & -30 POSITIONS ONLY) (USE MEC2-XX-XX-TH-NP) (SEE FIG 4, SHT 3)
-WT: WELD TABS (REQUIRED ON -02 CARD THICKNESS) (OPTIONAL ON -01 CARD THICKNESS) (SEE FIG 2, SHT 2)

No OF POS	POLARIZED POSITIONS
** -05	3, 4
** -08	5, 6
** -20	15, 16
** -30	21, 22
** -40	31, 32
** -50	41, 42

(**=NUMBER OF POSITIONS WILL BE REDUCED BY 1 PER ROW FOR POLARIZATION)

No OF POS	COPLANARITY
-05 THRU -30	0.102 [.0040]
-40 & -50	0.152 [.0060]

No. OF POS. PER ROW	"A"	"B"	"C"	"D"	"E"
-05	13.40 [.528]	11.50 [.453]	11.14 [.439]	8.00 [.315]	2.77 [.109]
-08	19.40 [.764]	17.50 [.689]	17.14 [.675]	14.00 [.551]	4.77 [.188]
-20	43.40 [1.709]	41.50 [1.634]	41.14 [1.620]	38.00 [1.496]	14.77 [.581]
-30	63.40 [2.496]	61.50 [2.421]	61.14 [2.407]	58.00 [2.283]	20.77 [.818]
-40	83.40 [3.283]	81.50 [3.209]	81.14 [3.194]	78.00 [3.071]	30.77 [1.211]
-50	103.40 [4.071]	101.50 [3.996]	101.14 [3.982]	98.00 [3.858]	40.77 [1.605]

No. OF POS. PER ROW	"F"	"G"	"H"	"J"	"K"
-05	N/A	4.000 [.1575]	N/A	4.00 [.157]	8.00 [.315]
-08	2.000 [.0787]	6.000 [.2362]	2.00 [.079]	6.00 [.236]	14.00 [.551]
-20	12.000 [.4724]	16.000 [.6299]	12.00 [.472]	16.00 [.630]	38.00 [1.496]
-30	18.000 [.7087]	22.000 [.8661]	18.00 [.709]	22.00 [.866]	58.00 [2.283]
-40	28.000 [1.1024]	32.000 [1.2598]	28.00 [1.102]	32.00 [1.260]	78.00 [3.071]
-50	38.000 [1.4961]	42.000 [1.6535]	38.00 [1.496]	42.00 [1.654]	98.00 [3.858]

UNLESS OTHERWISE SPECIFIED, DIMENSIONS ARE IN MILLIMETERS.

PROPRIETARY NOTE
THIS DOCUMENT CONTAINS CONFIDENTIAL AND PROPRIETARY INFORMATION AND ALL DESIGN, MANUFACTURING, REPRODUCTION, USE, PATENT RIGHTS AND SALES RIGHTS ARE EXPRESSLY RESERVED BY SAMTEC, INC. THIS DOCUMENT SHALL NOT BE DISCLOSED, IN WHOLE OR PART, TO ANY UNAUTHORIZED PERSON OR ENTITY NOR REPRODUCED, TRANSFERRED OR INCORPORATED IN ANY OTHER PROJECT IN ANY MANNER WITHOUT THE EXPRESS WRITTEN CONSENT OF SAMTEC, INC.

TOLERANCES ARE:
DECIMALS ANGLES
.X: ± .3 [.01]
.XX: ± .13 [.005]
.XXX: ± .051 [.0020]
2°

MATERIAL: DO NOT SCALE DRAWING SHEET SCALE: 1:0.4
INSULATOR: LCP, UL 94 V0
COLOR: -01 CARD THICKNESS BLACK, -02 CARD THICKNESS NATURAL
CONTACT: BeCu ALLOY



520 PARK EAST BLVD, NEW ALBANY, IN 47150
PHONE: 812-944-6733 FAX: 812-948-5047
e-Mail: info@SAMTEC.com code: 55322

DESCRIPTION: MEC2 2.0mm EDGE CARD ASSEMBLY
DWG. NO.

MEC2-XX-XX-X-XXX-XX-X-XX

BY: KNOWLDEN 2/14/10 SHEET 1 OF 3

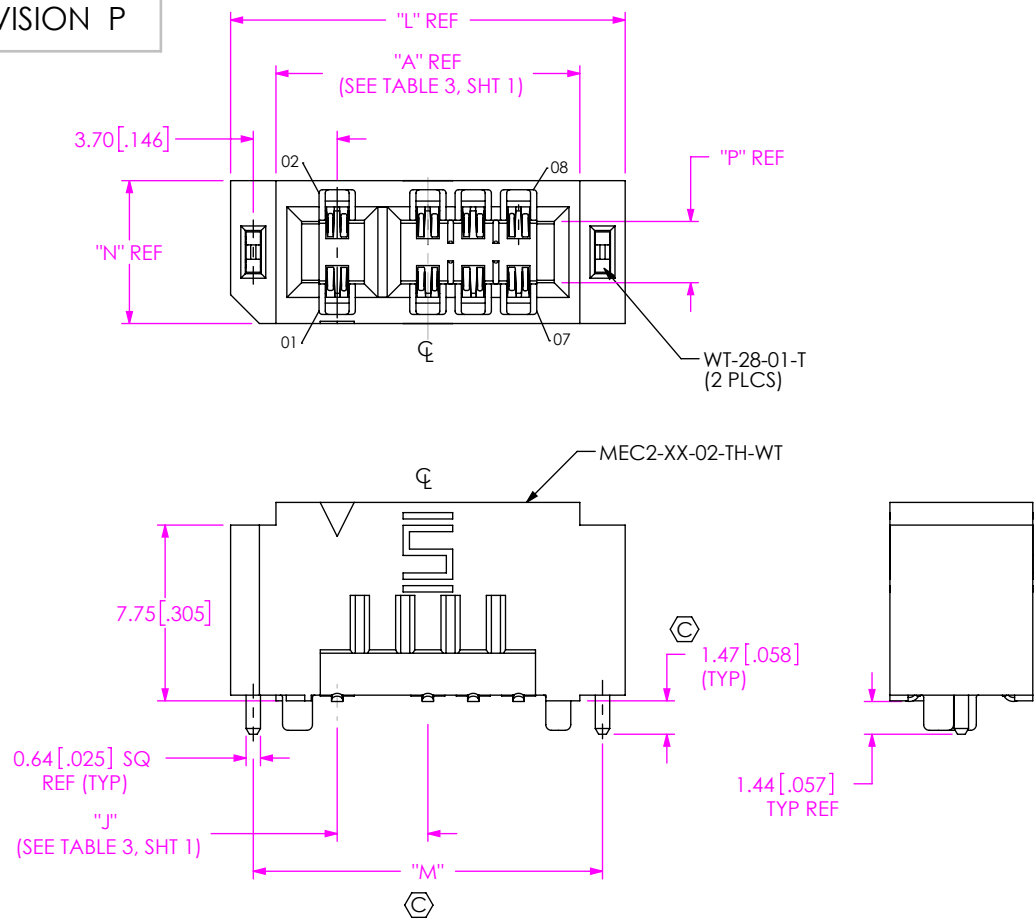
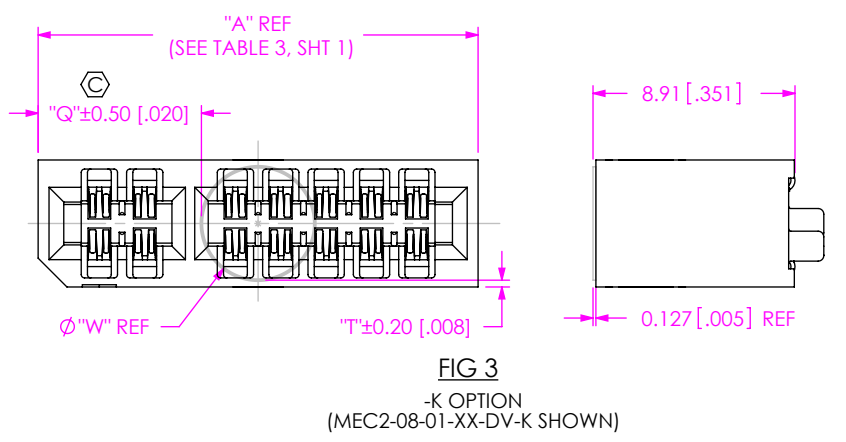
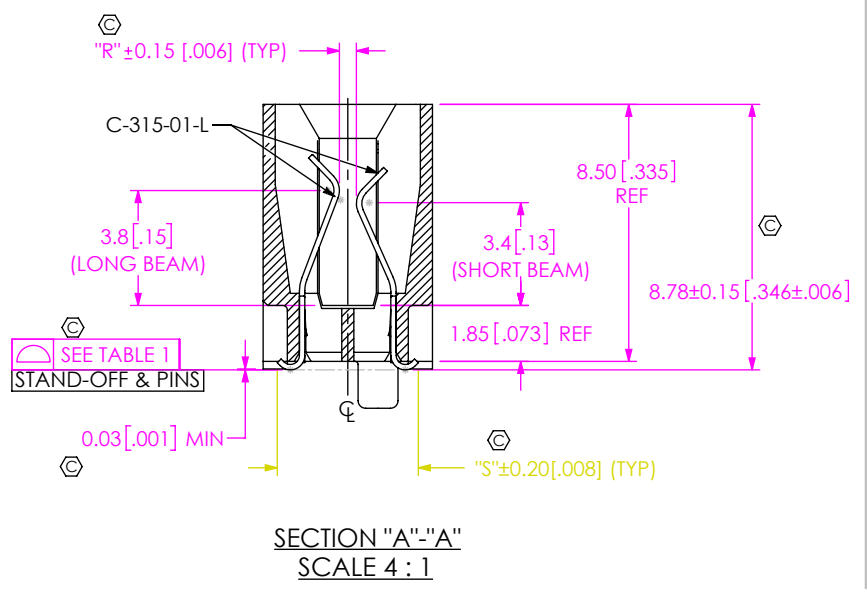

FIG 2
(MEC2-05-02-XX-DV-WT SHOWN)
(SAME AS FIG. 1, EXCEPT AS SHOWN)



CARD THICKNESS	"N"	"P"	"R"	"S"	"V"
-01 (.062 in)	5.60 [.220]	1.89 [.074]	0.55 [.022]	4.66 [.183]	3.02 [.119]
-02 (.093 in)	6.30 [.248]	2.68 [.106]	1.34 [.053]	5.45 [.215]	3.81 [.150]

No. OF POS. PER ROW	"L"	"M"
-05	17.40 [.685]	15.40 [.606]
-08	23.40 [.921]	21.40 [.843]
-20	47.40 [1.866]	45.40 [1.787]
-30	67.40 [2.654]	65.40 [2.575]
-40	87.40 [3.441]	85.40 [3.362]
-50	107.40 [4.228]	105.40 [4.150]

BOARD THICKNESS	W DIA.	"T"	"Q"				
			No OF POSITIONS PER ROW				
			-05	-08	-20	-30	KAPTON CALL-OUT
-01	5.00 [.197]	0.30	4.20 [.165]	7.20 [.283]	19.20 [.756]	29.20 [1.150]	K-DOT-.197-.344-.005
-02	6.00 [.236]	0.15	3.70 [.146]	6.70 [.264]	18.70 [.736]	28.70 [1.130]	K-DOT-.236-.343-.005
-01 WITH -WT	5.00 [.197]	0.30	6.20 [.244]	9.20 [.362]	21.20 [.835]	31.20 [1.228]	K-DOT-.197-.344-.005
-02 WITH -WT	6.00 [.236]	0.15	5.70 [.224]	8.70 [.343]	20.70 [.815]	30.70 [1.209]	K-DOT-.236-.343-.005

PROPRIETARY NOTE
THIS DOCUMENT CONTAINS CONFIDENTIAL AND PROPRIETARY INFORMATION AND ALL DESIGN, MANUFACTURING, REPRODUCTION, USE, PATENT RIGHTS AND SALES RIGHTS ARE EXPRESSLY RESERVED BY SAMTEC, INC. THIS DOCUMENT SHALL NOT BE DISCLOSED, IN WHOLE OR PART, TO ANY UNAUTHORIZED PERSON OR ENTITY NOR REPRODUCED, TRANSFERRED OR INCORPORATED IN ANY OTHER PROJECT IN ANY MANNER WITHOUT THE EXPRESS WRITTEN CONSENT OF SAMTEC, INC.



520 PARK EAST BLVD, NEW ALBANY, IN 47150
PHONE: 812-944-6733 FAX: 812-948-5047
e-Mail: info@SAMTEC.com code: 55322

DO NOT SCALE DRAWING
SHEET SCALE: 3:1

DESCRIPTION:
MEC2 2.0mm EDGE CARD ASSEMBLY

DWG. NO.
MEC2-XX-XX-X-XXX-XX-X-XX

BY: KNOWLDEN 2/14/10 SHEET 2 OF 3

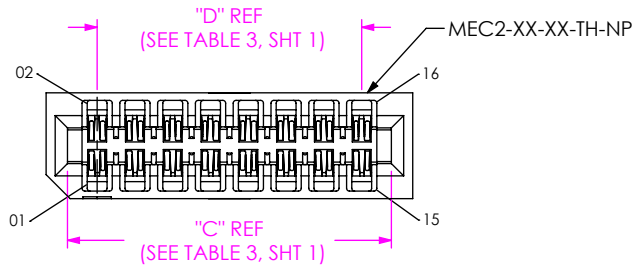

FIG 4
(MEC2-08-01-XX-XXX-NP SHOWN)
(SAME AS FIG. 1, EXCEPT AS SHOWN)

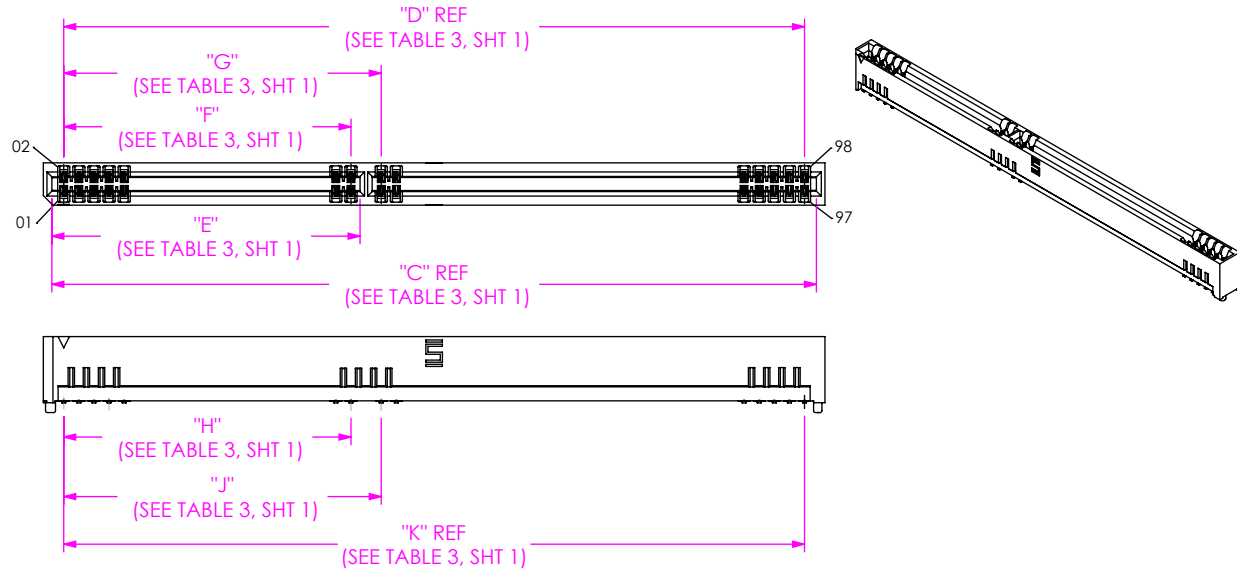

FIG 5
SCALE 1:1
(MEC2-50-01-XX-DV-XX SHOWN)
(SAME AS FIG 1, EXCEPT AS SHOWN)
(SOME CENTER FEATURES REMOVED FOR CLARITY)

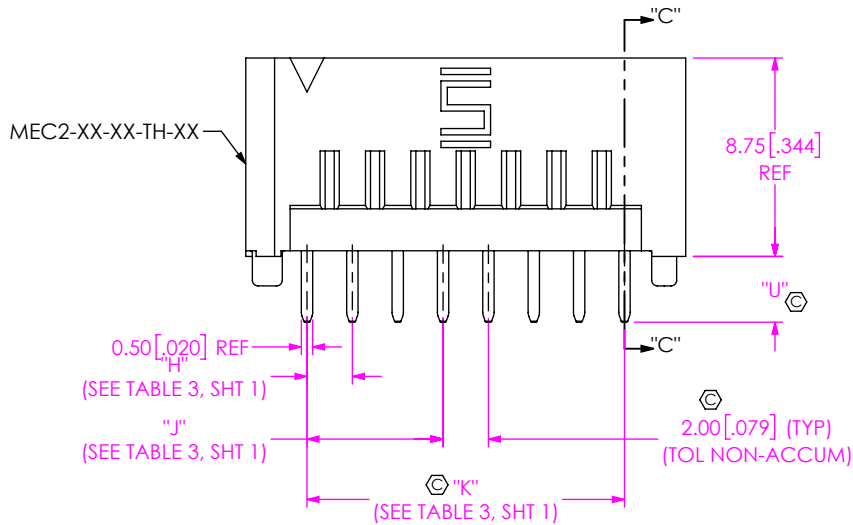
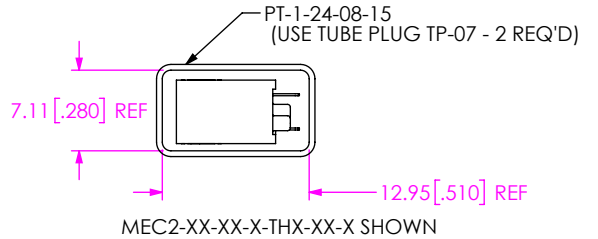
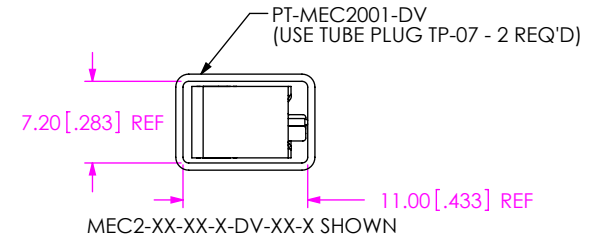

FIG 7
SCALE 3:1
MEC2-08-01-L-TH1-XX SHOWN
(SAME AS FIG 1, EXCEPT AS SHOWN)

TABLE 7		
ROW SPECS	"U"	CONTACT
-TH1	2.10 [.083]	C-411-01-L
-TH2	2.90 [.114]	C-411-02-L



PACKAGING VIEW

PROPRIETARY NOTE
THIS DOCUMENT CONTAINS CONFIDENTIAL AND PROPRIETARY INFORMATION AND ALL DESIGN, MANUFACTURING, REPRODUCTION, USE, PATENT RIGHTS AND SALES RIGHTS ARE EXPRESSLY RESERVED BY SAMTEC, INC. THIS DOCUMENT SHALL NOT BE DISCLOSED, IN WHOLE OR PART, TO ANY UNAUTHORIZED PERSON OR ENTITY NOR REPRODUCED, TRANSFERRED OR INCORPORATED IN ANY OTHER PROJECT IN ANY MANNER WITHOUT THE EXPRESS WRITTEN CONSENT OF SAMTEC, INC.

DO NOT SCALE DRAWING
SHEET SCALE: 5:2



520 PARK EAST BLVD, NEW ALBANY, IN 47150
PHONE: 812-944-6733 FAX: 812-948-5047
e-Mail: info@SAMTEC.com code: 55322

DESCRIPTION:
MEC2 2.0mm EDGE CARD ASSEMBLY

DWG. NO.
MEC2-XX-XX-X-XXX-XX-X-XX

BY: KNOWLDEN 2/14/10 SHEET 3 OF 3