

Dimensions are in millimeters

Shell size	PART NUMBER	PART NUMBER	A	B	C	D	E	F	G	H	I	J	K	L	M	∅N
E	863010	863010ASP206	15.27	2.4	2.4	24.99	30.55	20.21	12.3	12.7	12.28	10.74	18.6	20.8	24	8
A	863011	863011ASP206	19.44	2.4	3.2	33.32	38.89	28.55	12.3	12.7	12.28	10.74	27	20.8	24	10
B	863012	863012ASP206	26.39	3.2	4.75	47.04	52.78	42.29	12.3	12.7	12.28	10.74	40.5	20.8	24	15
C	863013	863013ASP206	34.53	3.2	6.35	63.50	69.06	58.75	12.3	12.7	12.28	10.74	56.96	20.8	24	18
D	863014	863014ASP206	33.34	3.2	4.75	61.11	66.67	56.36	12.3	15.4	15.15	13.02	55.03	20.8	24	20.6

packaging : 100 pieces packaging : 1 piece

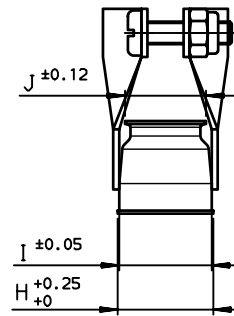
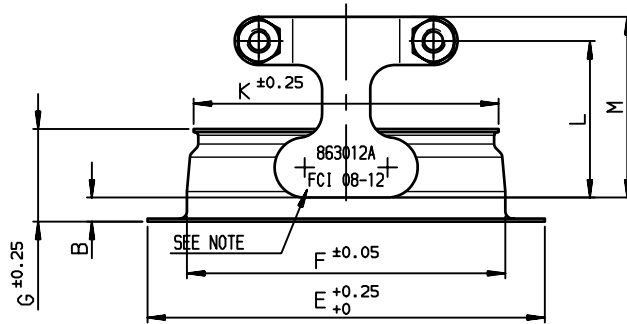

NOTES

- MATERIAL : STEEL
- PLATING : YELLOW CHROMATE CADMIUM
- CORROSION RESISTANCE : 50 HOURS EXPOSURE TO SALT SPRAY
- MARQUAGE REFERENCES SP206:
- REFERENCE SANS SP206+FCI et code annee semaine

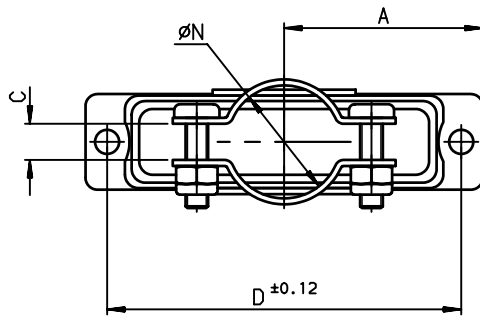

SEE TABLE

European Views

www.fciconnect.com		surface ISO 1302 ✓	tolerance std ISO 406 ISO 1101	projection A3	mm
TOLERANCES UNLESS OTHERWISE SPECIFIED					
Dr	ATC	1998/12/03	ANGULAR	0.X	±0.1
Eng	PESSON	1998/12/03	LINEAR	0.XX	±0.1
Chr	LEGARE	1998/12/03		0.XXX	±0.1
Appr	LEGARE	1998/12/03	Product family		D-SUB
				size	A3
				ECN	LS08-0117
				Spec ref	-
title METAL HOOD WITH CLAMP STRAIGHT EXIT			dwg no C01-8655-1522		Rev. D
catalog no			CUSTOMER		sheet 1 of 1

rev	ecn no	dr	date
B	-	JAR	2003/03/13
C	LS06-0097	LGO	2006/07/28
D	LS08-0117	MPE	2008/04/29
-	-	-	-
-	-	-	-
-	-	-	-