

## Description

The 5X1503 is a series of small form factor programmable clock generators intended for low-power, consumer, battery powered applications, wearable and smart devices.

The device is a 1 PLL + DCO architecture design with one embedded crystal. The device is OTP programmable, allowing for up to 3 unique frequency outputs. The 5X1503 has built-in unique features such as Proactive Power Saving (PPS) and a low power DCO to support system date/time keeping clock at 32.768kHz. Dynamic Frequency Control (DFC) supports dynamically changing between four different PLL frequencies via external requests with controlled frequency changes, reducing frequency overshoot and undershoot (ORT). The 5X1503S device can also support a spread clock for EMI reduction. For a description of terms and their functions, see [Glossary of Features](#).

An internal OTP memory allows the user to store up to four independent configurations that can be loaded on power-up without programming. It can then be reprogrammed again through the I<sup>2</sup>C interface.

The 5X1503 supports three LVCMOS type outputs. Two outputs have programmable amplitude. A low-power 32.768kHz clock is supported with only less than 1.5μA current consumption for system RTC reference clock needs.

5X1503 Base Number	Description	VCO Range (MHz)
5X1503	Standard, Integrated Crystal	50 – 130
5X1503L	Ultra Low-power, Integrated Crystal	50 – 130
5X1503S	Spread Clock, Integrated Crystal	500 – 1100

## Typical Applications

- SmartDevice
- Handheld
- Wearable applications
- Portable Consumer applications

## Features

- Proactive Power Saving (PPS) features save power during the end device power-down mode
- Dynamic Frequency Control (DFC) feature allows programming up to 4 difference frequencies that switch dynamically
- Programmable output clock amplitude (1V, 1.1V, 1.2V and 1.8V) to support low swing clock requirement
- Dedicated 32kHz output with 6 clock amplitude options (5X1503L)
- Integrated crystal; no external input source requirement
- Configurable through I2C or OTP programming
- Spread spectrum clock support (5X1503S)
- 1.8V operating supply voltage
- 2 × 2 mm 10-VFQFPN package

## Output Features

- 3 LVCMOS outputs, 1MHz–100MHz or 32.768kHz
- Low-power 32.768kHz clock supported

## Key Specifications

- Output cycle-cycle jitter: 50ps (typ)
- Low power-on fully active mode: 2mA (typ)
- Low-power 32.768kHz < 1.0μA (5X1503L)

# Contents

Description .....	1
Typical Applications .....	1
Features .....	1
Output Features .....	1
Key Specifications .....	1
Block Diagram .....	3
Pin Assignments .....	3
Pin Descriptions .....	4
Device Feature and Function .....	4
DFC – Dynamic Frequency Control .....	4
DFC Function Programming .....	5
PPS – Proactive Power Saving Function .....	5
PPS Function Programming .....	6
Output Divider Selection .....	6
Device Output Support .....	7
5X1503 .....	7
5X1503L .....	7
5X1503S .....	7
Input Pin Function .....	7
Spread Spectrum .....	9
Spread Spectrum .....	9
Digital Spread Spectrum .....	9
Absolute Maximum Ratings .....	10
Thermal Characteristics .....	10
Recommended Operating Conditions .....	10
Crystal Characteristics .....	11
DC Electrical Characteristics .....	11
AC Electrical Characteristics .....	12
I2C Bus DC Characteristics .....	14
Spread Spectrum Generation Specifications .....	15
General I2C Interface Information .....	16
How to Write .....	16
How to Read .....	16
Glossary of Features .....	26
Package Outline Drawings .....	27
Ordering Information .....	27
Marking Diagrams .....	27
Revision History .....	28

## Block Diagram

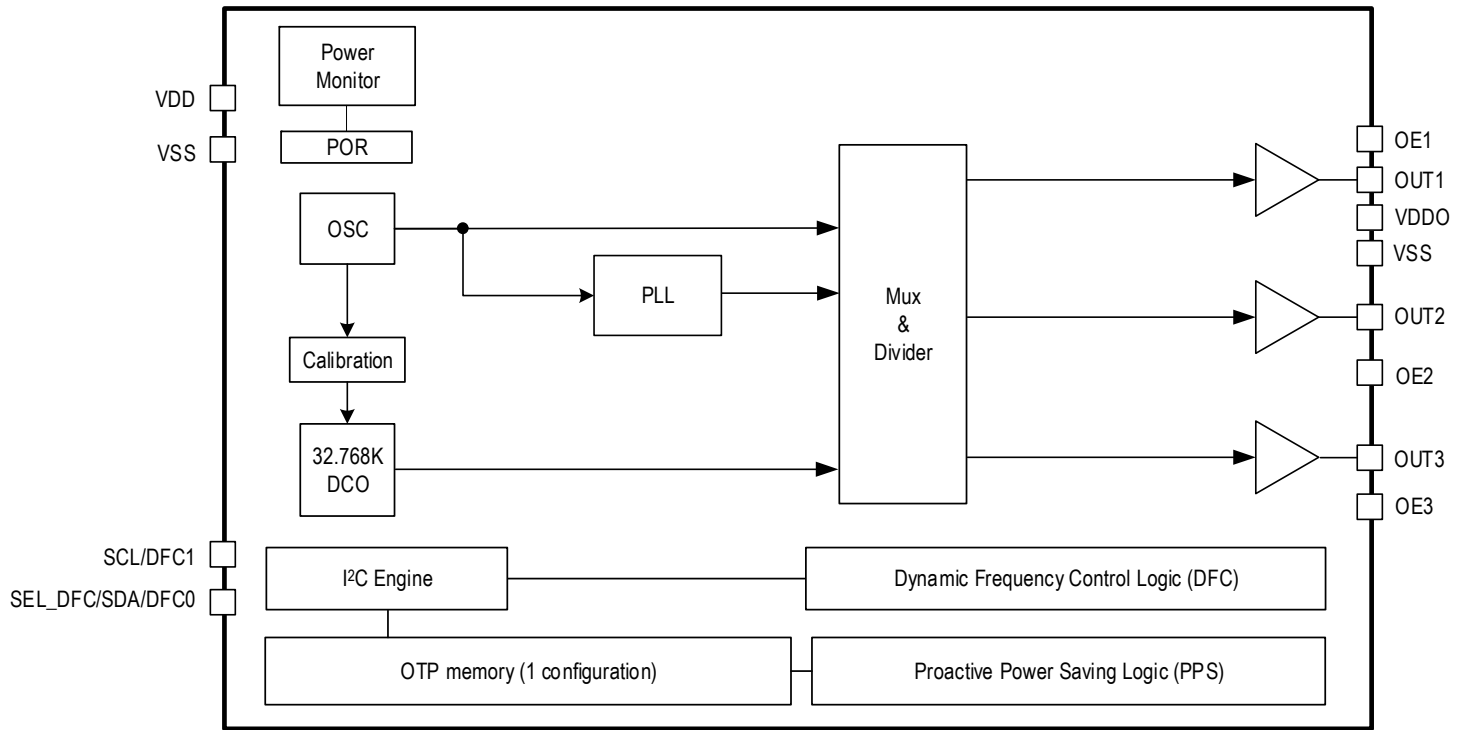

## Pin Assignments

Figure 1. Pin Assignments for 2.0 × 2.0 mm 10-VFQFPN Package

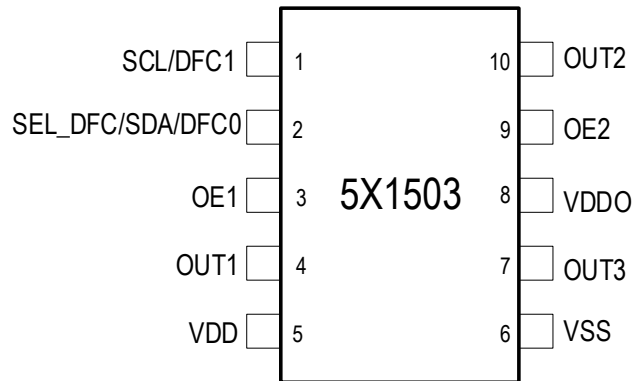

## Pin Descriptions

Table 1. Pin Descriptions

Number	Name	Type	Description
1	SCL/DFC1	Input	I2C clock pin/dynamic frequency input pin.
2	SEL_DFC /SDA/DFC0	I/O	Functional selection pin/I2C data pin/dynamic frequency input pin. 0 = HW mode; 0 = I2C mode.
3	OE1	Input	OUT1 output enable pin. The pin can be configured to other functions (DFC and PPS).
4	OUT1	Output	Programmable LVCMOS clock output (32.768kHz only on 5X1503L).
5	VDD	Power	1.8V power supply for core, PLL, and 32kHz DCO.
6	VSS	GND	Connect to ground.
7	OUT3	Output	Programmable LVCMOS clock output.
8	VDDO	Power	1.8V power supply for I/O.
9	OE2	Input	OUT2 output enable pin. The pin can be configured to other functions (DFC and PPS).
10	OUT2	Output	Programmable LVCMOS clock output.

## Device Feature and Function

### DFC – Dynamic Frequency Control

- OTP programmable—4 different feedback fractional dividers (4 VCO frequencies) that apply to PLL.
- ORT (overshoot reduction) function will be applied automatically during the VCO frequency change.
- Smooth frequency incremental or decremental from current VCO to targeted VCO based on DFC hardware pins selection.

Figure 2. DFC Function Block Diagram

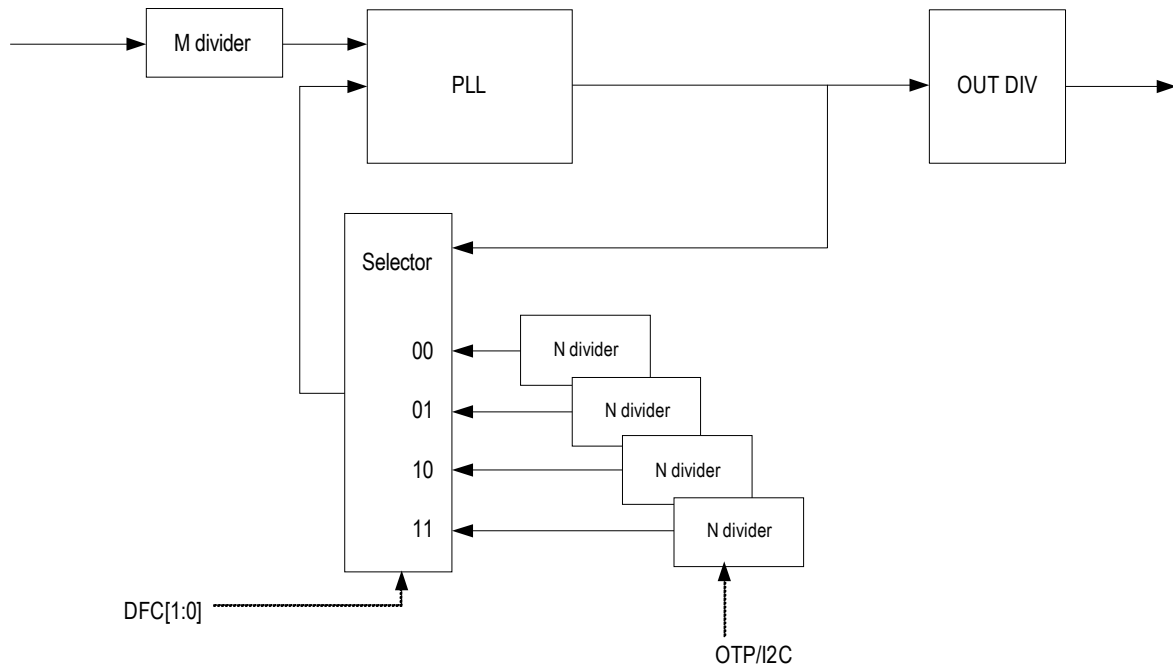

Table 2. DFC Function Priority

Mode	DFC_EN B17[0]	I2C Read/Write	SDA_DFC0 Latch	SCL_HW_Mode_sel B18[5]	OE1_fun_sel B16[6:5]	OE2_fun_sel B16[3:2]	DFC1	DFC1	Notes
x	0	Yes	x	x	x	x	x	x	DFC disable
SW	1	Yes	1	0	00–10	00 or 10	B0[1]	B0[0]	Select via I2C
HW	1	No	0	1	11	00–10	SCL	OE1	Select via pins
HW	1	No	0	1	00–10	00–10	SCL	SDA	Select via pins
HW	1	No	0	1	11	11	OE2	OE1	Select via pins
HW	1	No	0	1	11	01	—	OE1	Select via single pin

### DFC Function Programming

- Register B0b1:0 – select DFC00–DFC11 configuration.
- Byte5–8 are the registers for PLL VCO setting. Based on B0b1:0 configuration selection, the data write to B5–8 will be stored in selected configuration OTP memory.
- Refer to [DFC Function Priority](#) table. Select proper control pin(s) to activate DFC function.
- Note the DFC function can also be controlled by I2C access.

### PPS – Proactive Power Saving Function

PPS (Proactive Power Saving) is an IDT patented unique design for the clock generator that proactively detects end device power down state and then switches output clocks between normal operation clock frequency and low power mode 32kHz clock that only consumes < 1.5µA current. The system could save power when the device goes into power down or sleep mode. The PPS function diagram is shown as below.

Figure 3. PPS Function Block Diagram

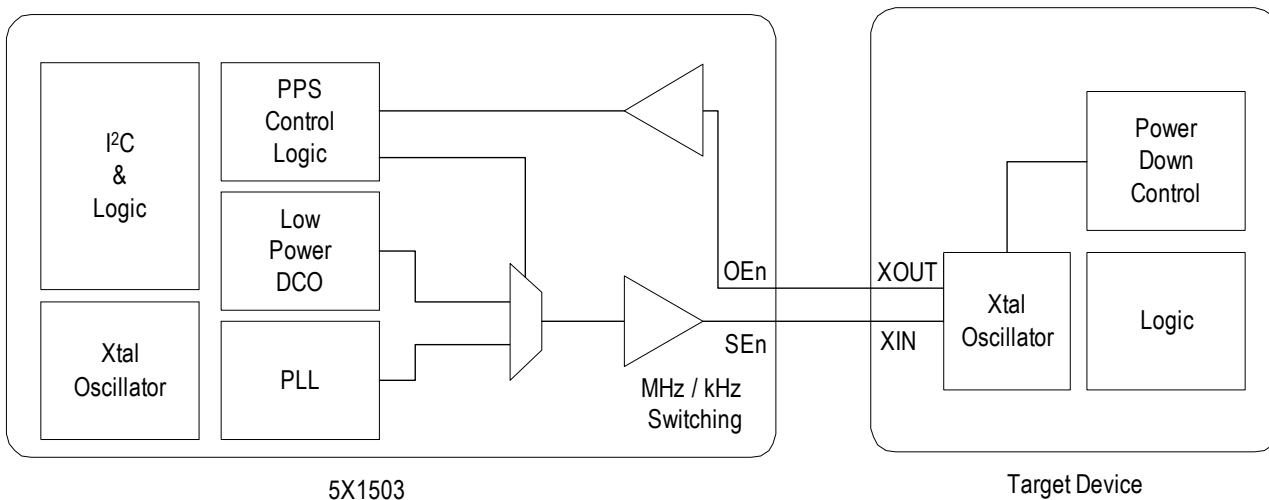
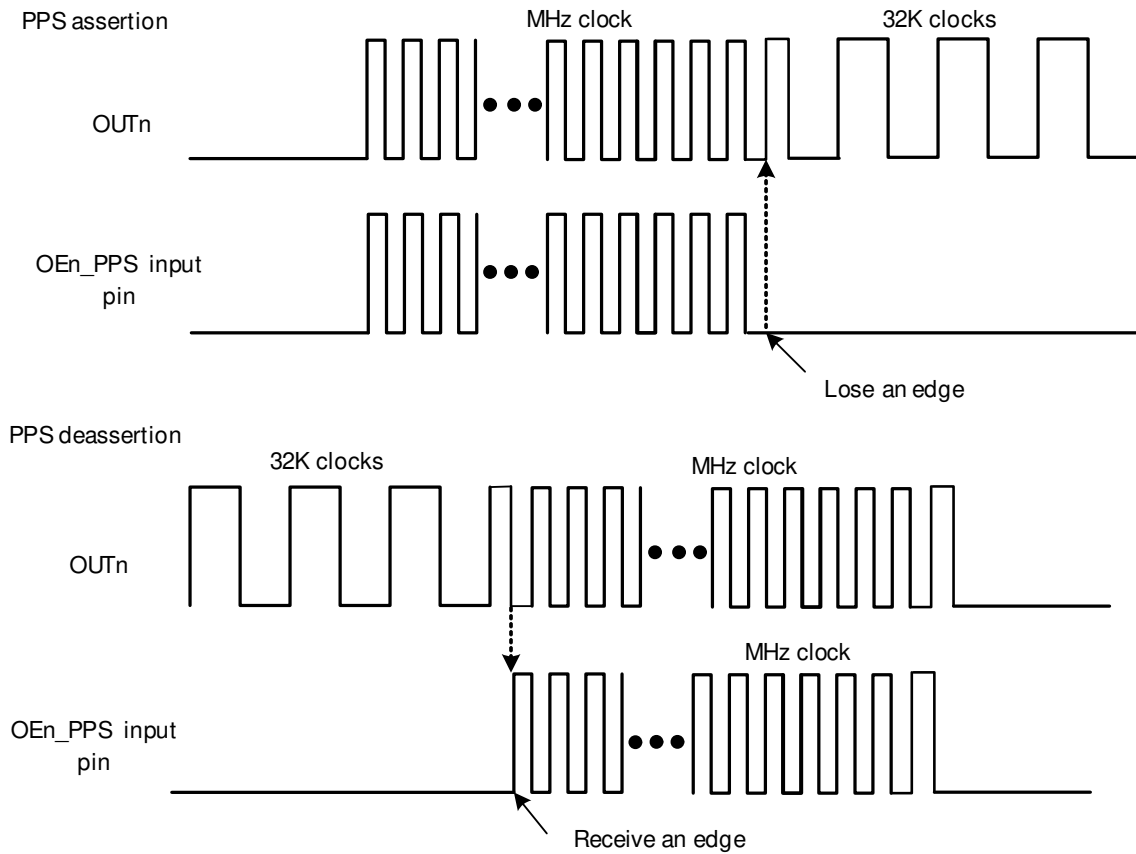

Figure 4. PPS Assertion/Deassertion Timing Chart



### PPS Function Programming

- Refer to the [OE Pin Function](#) table to have proper PPS function selected for OE pin(s). Note that the register default is set to Output Enable (OE) function for OE pins.
- Have proper setup to Byte 16 for OE1–OE2 function selection. For PPS function, select 10 to control register bits.

### Output Divider Selection

Table 3. Output Divider Selection

Output Divider bits<4:3>	Output Divider bits<2:0>					
	000	001	010	011	100	101
00	1	3	5	7	9	11
01	2	6	10	14	18	22
10	4	12	20	28	36	44
11	8	24	40	56	72	88

## Device Output Support

### 5X1503

Outputs	Frequency	Amplitude	VCO Range	Spread Spectrum
OUT1	32kHz or up to 100MHz LVCMOS	1.8V	50MHz – 130MHz	N/A
OUT2		1V, 1.1V, 1.2V, 1.8V		
OUT3				

### 5X1503L

Outputs	Frequency	Amplitude	VCO Range	Spread Spectrum
OUT1	32kHz	0.8V, 0.9V, 1V, 1.1V, 1.2V, 1.8V	50MHz – 130MHz	N/A
OUT2	32kHz or up to 100MHz LVCMOS	1V, 1.1V, 1.2V, 1.8V		
OUT3				

### 5X1503S

Outputs	Frequency	Amplitude	VCO Range	Spread Spectrum
OUT1	32kHz or up to 100MHz LVCMOS	1.8V	500MHz – 1100MHz	Available
OUT2		1V, 1.1V, 1.2V, 1.8V		
OUT3				

## Input Pin Function

OE pins in the 5X1503 have multiple functions. The OE pins can be configured as output enable control (OE) or chip power-down control (PD#) or Proactive Power Saving function (PPS). Furthermore, the OE1 pin can be configured as single or Dynamic Frequency Control (DFC).

Table 4. OE Pin Function

Function	OE1		OE2	
	B16<6:5>	Function	B16<3:2>	Function
Output Enable/Disable	00	OUT1 (Default)	00	OUT2 (Default)
Global Power Down (PD#)	01	PD#	01	Config_SEL
Proactive Power Saving Input	10	OUT1_PPS	10	OUT2_PPS
DFC Control	11	DFC0	11	DFC1

Note: Config\_SEL and DFC Control require the device to be in H/W mode with no I2C access

Table 5. OE Pin Function Summary

Pin	Function
OE1: OUT1	OE1 only control OUT1 enable/disable, other outputs are not affected by this pin status.
OE2: OUT2	OE2 only control OUT2 enable/disable, other outputs are not affected by this pin status.
OE1: PD#	OE1 control chip global power down (PD#) except 32.768kHz on OE1 (when 32K is enabled), When the PD# pin is active low, the chip goes to lowest power down mode and all outputs are disabled except 32kHz output and only keep 32k/Xtal calibration.
OE1: OUT1_PPS	Config OE1 as OUT1_PPS (Proactive Power Saving) function pin.
OE2: OUT2_PPS	Config OE2 as OUT2_PPS (Proactive Power Saving) function pin.
OE1:DFC0	Config OE1 as DFC0 control pin 0.
OE2:DFC1	Config OE2 as DFC1 control pin 1.

Table 6. PD# Priority

PD#	I2C_OE_EN_bit	OUT1/2/3, OUTx_PPS	Output	Notes
0	X	X	stop	32KHz free run
1	0	X	stop	
1	1	0	stop	
1	1	1	running	



# Spread Spectrum

## Spread Spectrum

The 5X1503 supports spread spectrum clocks from PLL with digital spread spectrum.

## Digital Spread Spectrum

Figure 5. Digital Spread Spectrum

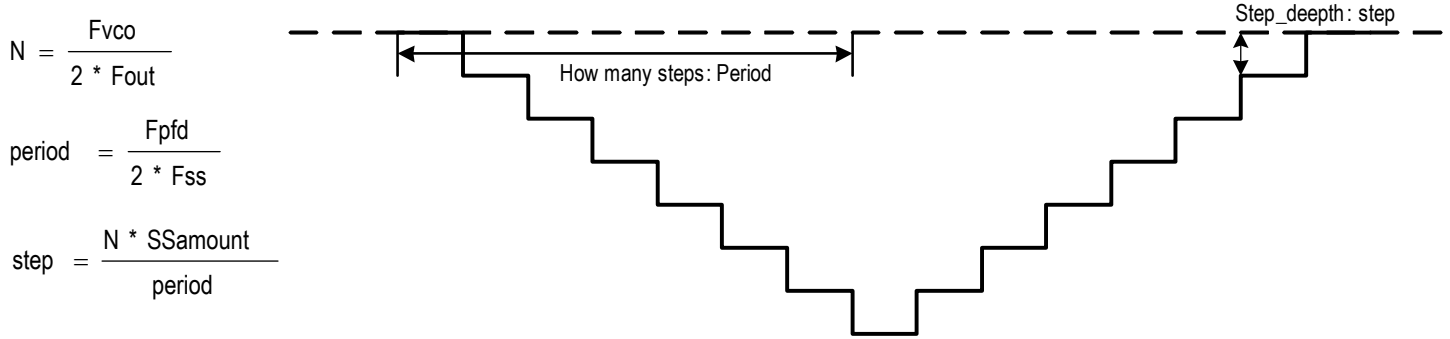

Down spread or spread off

$$N = F_{vco}/F_{pfd}$$

N: include integer and fraction

Fvco: VCOs frequency

Fpfd: PLLs pfd frequency

Fss: spread modulation rate

SSamount: spread percentage

N will decrease to make the center frequency lower than spread off.

Example: 0.5% down spread at 32kHz modulation rate.

## Absolute Maximum Ratings

Stresses above the ratings listed below can cause permanent damage to the 5X1503. These ratings, which are standard values for IDT commercially rated parts, are stress ratings only. Functional operation of the device at these or any other conditions above those indicated in the operational sections of the specifications is not implied. Exposure to absolute maximum rating conditions for extended periods can affect product reliability. Electrical parameters are guaranteed only over the recommended operating temperature range.

Table 7. Absolute Maximum Ratings

Item	Rating
Supply Voltage: $V_{DD}$ , $V_{DDO}$	-0.5V to 2.2V
Inputs: DFC, OE1, OE2, SCL	-0.5V to $V_{DD}/V_{DDO}$
Outputs: LVCMOS	-0.5V to $V_{DD}/V_{DDO} + 0.5V$
Outputs: SDA	10mA
Storage Temperature, $T_{STG}$	-65°C to 150°C
ESD Human Body Model	2000V
Junction Temperature	125°C

## Thermal Characteristics

Table 8. Thermal Characteristics

Symbol	Parameter	Value	Units
$\theta_{Jb}$	Theta $J_B$ . Junction to board	28.4	°C/W
$\theta_{Jc}$	Theta $J_C$ . Junction to case	183.3	°C/W
	Moisture Sensitivity Rating (per J-STD-020)	MSL1	—

## Recommended Operating Conditions

Table 9. Recommended Operating Conditions

Symbol	Parameter	Minimum	Typical	Maximum	Units
$V_{DDOUT1}$	Power Supply Voltage for Supporting OUT1	1.71	1.8	1.89	V
$V_{DDOUT2}$	Power Supply Voltage for Supporting OUT2/OUT3	1.71	1.8	1.89	V
$V_{DD1\_8}$	Power Supply Voltage for Core Logic Functions	1.71	1.8	1.89	V
$T_A$	Ambient Operating Temperature	-40	—	85	°C
$C_{LOAD\_OUT}$	Maximum Load Capacitance (1.8V LVCMOS only)	—	5	—	pF
$t_{PU}$	Power-up Time for all $V_{DDs}$ to reach Minimum Specified Voltage (power ramps must be monotonic)	0.05	—	3	ms

## Crystal Characteristics

Table 10. Embedded Crystal Characteristics

Parameter	Test Conditions	Minimum	Typical	Maximum	Units
Mode of Oscillation	—	Fundamental			
Frequency	—	—	52	—	MHz
Frequency Tolerance <sup>1</sup>	After trimming	—	—	±20	ppm
Equivalent Series Resistance (ESR)	—	—	—	80	Ω
Shunt Capacitance	—	—	2	7	pF
Load Capacitance (C <sub>L</sub> )	—	6	8	10	pF
Maximum Crystal Drive Level	—	—	—	100	μW

<sup>1</sup> Frequency tolerance includes initial frequency, over temperature range and aging data.

## DC Electrical Characteristics

Table 11. DC Electrical Characteristics – Current

V<sub>DD</sub> = V<sub>DDO</sub> = 1.8V ±5%, V<sub>SS</sub> = 0V, T<sub>A</sub> = -40°C to +85°C.

Symbol	Parameter	Conditions	Minimum	Typical	Maximum	Units
I <sub>dd</sub>	Core Supply Current (5X1503/5X1503L)	V <sub>DD</sub> = V <sub>DDO</sub> = 1.8V, Xtal = 52MHz, DCO = OFF, no output; PLL default.	—	—	2.0	mA
	Core Supply Current (5X1503S)	V <sub>DD</sub> = V <sub>DDO</sub> = 1.8V, Xtal = 52MHz, DCO = OFF, no output; PLL default.	—	—	9.5	mA
I <sub>dd_PLL</sub>	PLL Supply Current (5X1503/5X1503L)	V <sub>DD</sub> = V <sub>DDO</sub> = 1.8V, Xtal = 52MHz, no output; PLL= default	—	—	1.0	mA
	PLL Supply Current (5X1503S)	V <sub>DD</sub> = V <sub>DDO</sub> = 1.8V, Xtal = 52MHz, no output; PLL= default	—	—	9.0	mA
I <sub>ddox</sub>	Output Buffer Supply Current (5X1503/5X1503L)	LVC MOS, OUT1 = 8MHz, V <sub>DD</sub> = V <sub>DDO</sub> = 1.8V.	—	—	0.5	mA
		LVC MOS, OUT1 = 100MHz, V <sub>DD</sub> = V <sub>DDO</sub> = 1.8V.	—	—	2	mA
	Output Buffer Supply Current (5X1503S)	LVC MOS, OUT1 = 8MHz, V <sub>DD</sub> = V <sub>DDO</sub> = 1.8V.	—	—	0.5	mA
		LVC MOS, OUT1 = 100MHz, V <sub>DD</sub> = V <sub>DDO</sub> = 1.8V.	—	—	2	mA
I <sub>ddpd</sub>	Power Down Current (5X1503/5X1503L)	PD asserted with V <sub>DD</sub> and V <sub>DDO</sub> ON, I2C enable, 32.768kHz clock running.	—	—	310	μA
	Power Down Current (5X1503S)	PD asserted with V <sub>DD</sub> and V <sub>DDO</sub> ON, I2C enable, 32.768kHz clock running.	—	—	320	μA
I <sub>ddupd</sub>	Ultra Power Down Current (5X1503/5X1503L)	PD asserted with V <sub>DD</sub> and V <sub>DDO</sub> ON, I2C disable, 32.768kHz clock running.	—	—	7	μA
	Ultra Power Down Current (5X1503S)	PD asserted with V <sub>DD</sub> and V <sub>DDO</sub> ON, I2C disable, 32.768kHz clock running.	—	—	9.5	μA

Table 11. DC Electrical Characteristics – Current (Cont.)

$V_{DD} = V_{DDO} = 1.8V \pm 5\%$ ,  $V_{SS} = 0V$ ,  $T_A = -40^\circ C$  to  $+85^\circ C$ .

Symbol	Parameter	Conditions	Minimum	Typical	Maximum	Units
I <sub>ddsuspend</sub>	Power Suspend Current (5X1503)	$V_{DDD} = 1.8V$ , $V_{DDO} = GND$ , OUT1 = 32.768kHz running in DCO mode, no output loads, I2C and OE pins open.	—	—	1.4	$\mu A$
	Power Suspend Current (5X1503L)	$V_{DDD} = 1.8V$ , $V_{DDO} = GND$ , OUT1 = 32.768kHz running in DCO mode, no output loads, I2C and OE pins open.	—	—	1	$\mu A$
	Power Suspend Current (5X1503S)	$V_{DDD} = 1.8V$ , $V_{DDO} = GND$ , OUT1 = 32.768kHz running in DCO mode, no output loads, I2C and OE pins open.	—	—	1.4	$\mu A$

Table 12. DC Electrical Characteristics – Input and Output Voltage

Symbol	Parameter	Conditions	Minimum	Typical	Maximum	Units
$V_{OH}$	Output High Voltage	$I_{OH} = -8mA$ .	$0.7 \times V_{DDO}$	—	$V_{DDO}$	V
$V_{OL}$	Output Low Voltage	$I_{OL} = 8mA$ .	—	—	$0.25 \times V_{DDO}$	V
$I_{OZDD}$	Output Leakage Current	Tri-state outputs, $V_{DDO} = 1.89V$ .	—	—	80	$\mu A$
$V_{IH}$	Input High Voltage	Single-ended inputs – DFC, OE, SDA, SCL.	$0.65 \times V_{DDO}$	—	$V_{DDO} + 0.3$	V
$V_{IL}$	Input Low Voltage	Single-ended inputs – DFC, OE, SDA, SCL.	$GND - 0.3$	—	$0.35 \times V_{DDO}$	V

## AC Electrical Characteristics

Table 13. AC Timing Electrical Characteristics

$V_{DDSE} = 1.8V \pm 5\%$ ,  $T_A = -40^\circ C$  to  $+85^\circ C$ . Spread spectrum = OFF.

Symbol	Parameter	Conditions	Minimum	Typical	Maximum	Units
$f_{IN}$	Integrated Xtal Frequency	Input frequency limit (XIN) <sup>1</sup> .	—	52	—	MHz
$f_{OUT}$	Output Frequency	Single-ended clock output limit (LVCMOS).	1	—	100	MHz
$f_{VCO1}$	VCO Frequency Range of PLL	VCO operating frequency range (5X1503).	50	—	130	MHz
$f_{VCO2}$	VCO Frequency Range of PLL	VCO operating frequency range (5X1503L).	50	—	130	MHz
$f_{VCO3}$	VCO Frequency Range of PLL	VCO operating frequency range (5X1503S).	500	—	1100	MHz
$f_{PFD1}$	PFD Frequency Range of PLL1	PFD operating frequency range (5X1503 and 5X1503L).	0	—	0.125	MHz
$f_{PFD1}$	PFD Frequency Range of PLL1	PFD operating frequency range (5X1503S).	0.8	—	100	MHz
$f_{BW1}$	Loop Bandwidth for PLL1	Input frequency = 52MHz.	0.001	—	1	MHz
$F_{32K\_ACC1}$	32K Stability	Average accuracy after 24 hours <sup>2</sup> .	—	—	42	ppm
$F_{32K\_ACC2}$	32K Stability	Average accuracy after 3 days <sup>2</sup> .	—	—	36	ppm
$F_{32K\_ACC3}$	32K Stability	Average accuracy after 7 days <sup>2</sup> .	—	—	32	ppm

Table 13. AC Timing Electrical Characteristics (Cont.)

$V_{DDSE} = 1.8V \pm 5\%$ ,  $T_A = -40^\circ C$  to  $+85^\circ C$ . Spread spectrum = OFF.

Symbol	Parameter	Conditions	Minimum	Typical	Maximum	Units
	Minimum Input Amplitude	For a 40/60% SE input duty cycle.	800	—	$V_{DD}$	mV
t2	Input Duty Cycle	Duty cycle.	30	—	70	%
t3	Output Duty Cycle	Measured at $V_{DD}/2$ , all outputs with a crystal or a 50% input duty cycle clock.	45	—	55	%
t4 <sup>3</sup>	Rise/Fall Slew Rate	1.8V LVCMOS clock rise and fall time, 20% to 80% of $V_{DDO}/V_{DD}$ (output load = 2 pF).	—	2.0	—	V/ns
t4 <sup>3</sup>	Rise/Fall Slew Rate	1.2V LVCMOS clock rise and fall time, 20% to 80% of $V_{DDO}/V_{DD}$ (output load = 2 pF). Byte19<3:2> = 11 Byte19<1:0> = 11.	—	1.1	—	V/ns
t4 <sup>3</sup>	Rise/Fall Slew Rate	1.1V LVCMOS clock rise and fall time, 20% to 80% of $V_{DDO}/V_{DD}$ (output load = 2 pF).	—	1.0	—	V/ns
t4 <sup>3</sup>	Rise/Fall Slew Rate	1.0V LVCMOS clock rise and fall time, 20% to 80% of $V_{DDO}/V_{DD}$ (output load = 2 pF).	—	1.0	—	V/ns
t4 <sup>3</sup>	Rise/Fall Slew	OUT1 1.8V 32kHz LVCMOS clock rise and fall time, 20% to 80% of $V_{DDO}/V_{DD}$ , Byte20<2:0>=000 (5X1503L).	—	27.4	—	V/μs
t4 <sup>3</sup>	Rise/Fall Slew	OUT1 0.8V 32kHz LVCMOS clock rise and fall time, 20% to 80% of $V_{DDO}/V_{DD}$ , Byte20<2:0> = 001 (5X1503L).	—	2.3	—	V/μs
t4 <sup>3</sup>	Rise/Fall Slew	OUT1 0.9V 32kHz LVCMOS clock rise and fall time, 20% to 80% of $V_{DDO}/V_{DD}$ , Byte20<2:0> = 010 (5X1503L).	—	3.9	—	V/μs
t4 <sup>3</sup>	Rise/Fall Slew	OUT1 1.0V 32kHz LVCMOS clock rise and fall time, 20% to 80% of $V_{DDO}/V_{DD}$ , Byte20<2:0> = 011 (5X1503L).	—	5.4	—	V/μs
t4 <sup>3</sup>	Rise/Fall Slew	OUT1 1.1V 32kHz LVCMOS clock rise and fall time, 20% to 80% of $V_{DDO}/V_{DD}$ , Byte20<2:0> = 100 (5X1503L).	—	6.7	—	V/μs
t4 <sup>3</sup>	Rise/Fall Slew	OUT1 1.2V 32kHz LVCMOS clock rise and fall time, 20% to 80% of $V_{DDO}/V_{DD}$ , Byte20<2:0> = 101 (5X1503L).	—	8.5	—	V/μs
t6 <sup>4</sup>	Clock Jitter	Cycle-to-cycle jitter, 1.8V LVCMOS output clock. OUT1 = 32.768KHz (1.8V LVCMOS) OUT2 = 72MHz OUT3 = 26MHz	—	50	—	ps
t6 <sup>4</sup>	Clock Jitter	Cycle-to-cycle jitter, 1.2V LVCMOS output clock. OUT1 = 32.768KHz (1.8V LVCMOS) OUT2 = 72MHz OUT3 = 26MHz	—	50	—	ps

Table 13. AC Timing Electrical Characteristics (Cont.)

$V_{DDSE} = 1.8V \pm 5\%$ ,  $T_A = -40^\circ C$  to  $+85^\circ C$ . Spread spectrum = OFF.

Symbol	Parameter	Conditions	Minimum	Typical	Maximum	Units
$t6^4$	Clock Jitter	Cycle-to-cycle jitter, 1.1V LVCMOS output clock OUT1 = 32.768kHz (1.8V LVCMOS) OUT2 = 72MHz OUT3 = 26MHz	—	50	—	ps
$t6^4$	Clock Jitter	Cycle-to-cycle jitter, 1.0V LVCMOS output clock. OUT1 = 32.768kHz (1.8V LVCMOS) OUT2 = 72MHz OUT3 = 26MHz	—	50	—	ps
$t7$	Output Skew	Skew between the same frequencies, with outputs using the same driver format.	—		300	ps
$t8^5$	Lock Time	PLL lock time from power-up.	—		5	ms
$t9$	Lock Time	32.768kHz clock low power power-up time.	—	10	20	ms

<sup>1</sup> High Drive only when crystal frequency is higher than 30MHz.

<sup>2</sup> The data is measured on constant temperature.

<sup>3</sup> The slew rate is set by Byte19<3:2> and Byte19<1:0>.

<sup>4</sup> Jitter performance depend on output configuration.

<sup>5</sup> Includes loading the configuration bits from EPROM to PLL registers. It does not include EPROM programming/write time.

<sup>6</sup> Actual PLL lock time depends on the loop configuration.

## I<sup>2</sup>C Bus DC Characteristics

Table 14. I<sup>2</sup>C Bus DC Characteristics

Symbol	Parameter	Conditions	Minimum	Typical	Maximum	Units
$V_{IH}$	Input High Level	—	$0.7 \times V_{DDO}$	—	—	V
$V_{IL}$	Input Low Level	—	—	—	$0.3 \times V_{DDO}$	V
$V_{HYS}$	Hysteresis of Inputs	—	$0.05 \times V_{DDO}$	—	—	V
$I_{IN}$	Input Leakage Current	—	—	1	10	$\mu A$
$V_{OL}$	Output Low Voltage	$I_{OL} = 3mA$ .	—	—	0.4	V

Note: I2C bus is 3.3V tolerant.

Table 15. I<sup>2</sup>C Bus AC Characteristics

Symbol	Parameter	Minimum	Typical	Maximum	Units
F <sub>SCLK</sub>	Serial Clock Frequency (SCL)	—	100	400	kHz
t <sub>BUF</sub>	Bus Free Time between STOP and START	1.3	—	—	μs
t <sub>SU:START</sub>	Setup Time, START	0.6	—	—	μs
t <sub>HD:START</sub>	Hold Time, START	0.6	—	—	μs
t <sub>SU:DATA</sub>	Setup Time, Data Input (SDA)	100	—	—	ns
t <sub>HD:DATA</sub>	Hold Time, Data Input (SDA) <sup>1</sup>	0	—	—	μs
t <sub>OVD</sub>	Output Data Valid from Clock	—	—	0.9	μs
C <sub>B</sub>	Capacitive Load for Each Bus Line	—	—	400	pF
t <sub>R</sub>	Rise Time, Data and Clock (SDA, SCL)	20 + 0.1 × C <sub>B</sub>	—	300	ns
t <sub>F</sub>	Fall Time, Data and Clock (SDA, SCL)	20 + 0.1 × C <sub>B</sub>	—	300	ns
t <sub>HIGH</sub>	High Time, Clock (SCL)	0.6	—	—	μs
t <sub>LOW</sub>	Low Time, Clock (SCL)	1.3	—	—	μs
t <sub>SU:STOP</sub>	Setup Time, STOP	0.6	—	—	μs

<sup>1</sup> A device must internally provide a hold time of at least 300ns for the SDA signal (referred to the V<sub>IH(MIN)</sub> of the SCL signal) to bridge the undefined region of the falling edge of SCL.

## Spread Spectrum Generation Specifications

Table 16. Spread Spectrum Generation Specifications (5X1503S only)

Symbol	Parameter	Description	Minimum	Typical	Maximum	Units
f <sub>OUT</sub>	Output Frequency	Output frequency range.	1	—	100	MHz
f <sub>MOD</sub>	Mod Frequency	Modulation frequency.	30 – 63			kHz
f <sub>SPREAD</sub>	Spread Value	Amount of spread value (programmable)–down spread.	0.15% – 2.0%			% f <sub>OUT</sub>

## General I2C Interface Information

### How to Write

- Controller (host) sends a start bit
- Controller (host) sends the write address
- IDT clock will acknowledge
- Controller (host) sends the beginning byte location = N
- IDT clock will acknowledge
- Controller (host) sends the byte count = X
- IDT clock will acknowledge
- Controller (host) starts sending Byte N through Byte N+X-1
- IDT clock will acknowledge each byte one at a time
- Controller (host) sends a stop bit

Index Block Write Operation			
Controller (Host)		IDT (Slave/Receiver)	
T	starT bit		
Slave Address			
WR	WRite		
			ACK
Beginning Byte = N			
			ACK
Data Byte Count = X			
			ACK
Beginning Byte N		X Byte	
			ACK
O			O
O			O
O			O
Byte N + X - 1			
			ACK
P	stoP bit		

### How to Read

- Controller (host) will send a start bit
- Controller (host) sends the write address
- IDT clock will acknowledge
- Controller (host) sends the beginning byte location = N
- IDT clock will acknowledge
- Controller (host) will send a separate start bit
- Controller (host) sends the read address
- IDT clock will acknowledge
- IDT clock will send the data byte count = X
- IDT clock sends Byte N+X-1
- IDT clock sends Byte 0 through Byte X (if  $X_{(H)}$  was written to Byte 8)
- Controller (host) will need to acknowledge each byte
- Controller (host) will send a not acknowledge bit
- Controller (host) will send a stop bit

Index Block Read Operation			
Controller (Host)		IDT (Slave/Receiver)	
T	starT bit		
Slave Address			
WR	WRite		
			ACK
Beginning Byte = N			
			ACK
RT	Repeat starT		
Slave Address			
RD	ReaD		
			ACK
			Data Byte Count=X
			ACK
		X Byte	Beginning Byte N
			O
			O
			O
			O
			Byte N + X - 1
N	Not acknowledge		
P	stoP bit		



### Byte 0: General Control

Byte 00h	Name	Control Function	Type	0	1	PWD
Bit 7	OTP_Burned	OTP memory programming indication	R/W	OTP memory non-programmed	OTP memory programmed	0
Bit 6	OTP TRIM	OTP memory programming indication	R/W	OTP TRIM bits non-programmed	OTP TRIM bits programmed	0
Bit 5	I2C_addr[1]	I2C address select bit 1	R/W	00: D0 / 01: D2 10: D4 / 11: D6		0
Bit 4	I2C_addr[0]	I2C address select bit 0	R/W			0
Bit 3	OTP TRIM Protect	OTP TRIM bits memory protection	R/W	read/write	write locked	0
Bit 2	OTP Configure Select 2	OTP Config Select Bit	R/W	Config 0	Config 1	0
Bit 1	OTP Configure Select <1>	DFC Config Select Bit 1	R/W	00: DFC Config 0 01: DFC Config 1 10: DFC Config 2 11: DFC Config 3		0
Bit 0	OTP Configure Select <0>	DFC Config Select Bit 0	R/W			0

### Byte 1: Dash Code ID (optional)

Byte 01h	Name	Control Function	Type	0	1	PWD
Bit 7	XTAL_DIV2	XTAL Divider	R/W	Div /2	Bypass	0
Bit 6	DashCode ID[6]	Dash code ID	R/W	—	—	0
Bit 5	DashCode ID[5]	Dash code ID	R/W	—	—	0
Bit 4	DashCode ID[4]	Dash code ID	R/W	—	—	0
Bit 3	DashCode ID[3]	Dash code ID	R/W	—	—	0
Bit 2	DashCode ID[2]	Dash code ID	R/W	—	—	0
Bit 1	DashCode ID[1]	Dash code ID	R/W	—	—	0
Bit 0	DashCode ID[0]	Dash code ID	R/W	—	—	0

### Byte 2: Crystal Cap Setting

Byte 02h	Name	Control Function	Type	0	1	PWD
Bit 7	Xtal_Cap[3]	Xtal cap load trimming bits	R/W	x1 x2 x4 x8 total 15pF		0
Bit 6	Xtal_Cap[2]	Xtal cap load trimming bits	R/W			0
Bit 5	Xtal_Cap[1]	Xtal cap load trimming bits	R/W			0
Bit 4	Xtal_Cap[0]	Xtal cap load trimming bits	R/W			1
Bit 3	PPS Hyst Prog	PPS Hysteresis Prog Bit1	R/W	00: 20mV 01: 40mV 10: 60mV 11: 80mV		0
Bit 2	PPS Hyst Prog	PPS Hysteresis Prog Bit0	R/W			0
Bit 1	PPS Vbias Prog	PPS Vbias Prog Bit 1	R/W	—	—	0
Bit 0	PPS Vbias Prog	PPS Vbias Prog Bit 0	R/W	—	—	0

**Byte 3: OTP Protect**

Byte 03h	Name	Control Function	Type	0	1	PWD
Bit 7	OTP Configure 3 Protect	—	R/W	read/write	write locked	0
Bit 6	OTP Configure 2 Protect	—	R/W	read/write	write locked	0
Bit 5	OTP Configure 1 Protect	—	R/W	read/write	write locked	0
Bit 4	OTP Configure 0 Protect	—	R/W	read/write	write locked	0
Bit 3	PPS2 Amp Prog	PPS OE2 Amplitude Prog Bit 1	R/W	00: 400mV 01: 500mV 10: 600mV 11: 700mV		0
Bit 2	PPS2 Amp Prog	PPS OE2 Amplitude Prog Bit 0	R/W			0
Bit 1	PPS1 Amp Prog	PPS OE1 Amplitude Prog Bit 1	R/W	00: 400mV 01: 500mV 10: 600mV 11: 700mV		0
Bit 0	PPS1 Amp Prog	PPS OE1 Amplitude Prog Bit 0	R/W			0

**Byte 4: (Apply to 5X1503S)**

Byte 04h	Name	Control Function	Type	0	1	PWD
Bit 7	UltraPowerDown	Ultra Power Down	R/W	disabled	enabled	0
Bit 6	EN DIFF CLKIN	Enable Differential Clkin on X1/X2	R/W	disabled	enabled	0
Bit 5	PLL HRS EN	-	R/W	normal	enable (shift 4 bits)	0
Bit 4	PLL EN 3rd	-	R/W	disabled	enabled	0
Bit 3	Reserved		R/W	—	—	0
Bit 2	PLL_FB_INT[10]	PLL feedback integer divider 10	R/W	—	—	0
Bit 1	PLL_FB_INT[9]	PLL feedback integer divider 9	R/W	—	—	0
Bit 0	PLL_FB_INT[8]	PLL feedback integer divider 8	R/W	—	—	0

**Byte 4: (Apply to 5X1503/5X1503L)**

Byte 04h	Name	Control Function	Type	0	1	PWD
Bit 7	UltraPowerDown	Ultra Power Down	R/W	disabled	enabled	0
Bit 6	EN DIFF CLKIN	Enable Differential Clkin on X1/X2	R/W	disabled	enabled	0
Bit 5	PLL HRS EN	—	R/W	normal	enable (shift 4 bits)	0
Bit 4	PLL EN 3rd	—	R/W	disabled	enabled	0
Bit 3	SEL_PREDIV	Divide by 4	R/W	disabled	enabled	0
Bit 2	PLL_FB_INT[10]	PLL feedback integer divider 10	R/W	—	—	0
Bit 1	PLL_FB_INT[9]	PLL feedback integer divider 9	R/W	—	—	0
Bit 0	PLL_FB_INT[8]	PLL feedback integer divider 8	R/W	—	—	0

Byte 5: PLL Integer Feedback Divider (Apply to 5X1503S)

Byte 05h	Name	Control Function	Type	0	1	PWD
Bit 7	PLL_FB_INT_DIV[7]	PLL feedback integer divider 7	R/W	—	—	0
Bit 6	PLL_FB_INT_DIV[6]	PLL feedback integer divider 6	R/W	—	—	0
Bit 5	PLL_FB_INT_DIV[5]	PLL feedback integer divider 5	R/W	—	—	1
Bit 4	PLL_FB_INT_DIV[4]	PLL feedback integer divider 4	R/W	—	—	0
Bit 3	PLL_FB_INT_DIV[3]	PLL feedback integer divider 3	R/W	—	—	1
Bit 2	PLL_FB_INT_DIV[2]	PLL feedback integer divider 2	R/W	—	—	0
Bit 1	PLL_FB_INT_DIV[1]	PLL feedback integer divider 1	R/W	—	—	0
Bit 0	PLL_FB_INT_DIV[0]	PLL feedback integer divider 0	R/W	—	—	0

Byte 5: PLL Integer Feedback Divider (Apply to 5X1503/5X1503L)

Byte 05h	Name	Control Function	Type	0	1	PWD
Bit 7	PLL_FB_INT_DIV[7]	PLL feedback integer divider 7	R/W	—	—	0
Bit 6	PLL_FB_INT_DIV[6]	PLL feedback integer divider 6	R/W	—	—	0
Bit 5	PLL_FB_INT_DIV[5]	PLL feedback integer divider 5	R/W	—	—	1
Bit 4	PLL_FB_INT_DIV[4]	PLL feedback integer divider 4	R/W	—	—	1
Bit 3	PLL_FB_INT_DIV[3]	PLL feedback integer divider 3	R/W	—	—	0
Bit 2	PLL_FB_INT_DIV[2]	PLL feedback integer divider 2	R/W	—	—	0
Bit 1	PLL_FB_INT_DIV[1]	PLL feedback integer divider 1	R/W	—	—	0
Bit 0	PLL_FB_INT_DIV[0]	PLL feedback integer divider 0	R/W	—	—	0

Byte 6: PLL Fractional Feedback Divider

Byte 06h	Name	Control Function	Type	0	1	PWD
Bit 7	PLL_FB_FRC_DIV[15]	PLL feedback fractional divider 15	R/W	—	—	0
Bit 6	PLL_FB_FRC_DIV[14]	PLL feedback fractional divider 14	R/W	—	—	0
Bit 5	PLL_FB_FRC_DIV[13]	PLL feedback fractional divider 13	R/W	—	—	0
Bit 4	PLL_FB_FRC_DIV[12]	PLL feedback fractional divider 12	R/W	—	—	0
Bit 3	PLL_FB_FRC_DIV[11]	PLL feedback fractional divider 11	R/W	—	—	0
Bit 2	PLL_FB_FRC_DIV[10]	PLL feedback fractional divider 10	R/W	—	—	0
Bit 1	PLL_FB_FRC_DIV[9]	PLL feedback fractional divider 9	R/W	—	—	0
Bit 0	PLL_FB_FRC_DIV[8]	PLL feedback fractional divider 8	R/W	—	—	0

### Byte 7: Fractional Feedback Divider

Byte 07h	Name	Control Function	Type	0	1	PWD
Bit 7	PLL_FB_FRC_DIV[7]	PLL feedback fractional divider 7	R/W	—	—	0
Bit 6	PLL_FB_FRC_DIV[6]	PLL feedback fractional divider 6	R/W	—	—	0
Bit 5	PLL_FB_FRC_DIV[5]	PLL feedback fractional divider 5	R/W	—	—	0
Bit 4	PLL_FB_FRC_DIV[4]	PLL feedback fractional divider 4	R/W	—	—	0
Bit 3	PLL_FB_FRC_DIV[3]	PLL feedback fractional divider 3	R/W	—	—	0
Bit 2	PLL_FB_FRC_DIV[2]	PLL feedback fractional divider 2	R/W	—	—	0
Bit 1	PLL_FB_FRC_DIV[1]	PLL feedback fractional divider 1	R/W	—	—	0
Bit 0	PLL_FB_FRC_DIV[0]	PLL feedback fractional divider 0	R/W	—	—	0

### Byte 8: PLL Spread Spectrum Control

Byte 08h	Name	Control Function	Type	0	1	PWD
Bit 7	PLL_STEP[15]	PLL spread step size control bit 15	R/W	—	—	0
Bit 6	PLL_STEP[14]	PLL spread step size control bit 14	R/W	—	—	0
Bit 5	PLL_STEP[13]	PLL spread step size control bit 13	R/W	—	—	0
Bit 4	PLL_STEP[12]	PLL spread step size control bit 12	R/W	—	—	0
Bit 3	PLL_STEP[11]	PLL spread step size control bit 11	R/W	—	—	0
Bit 2	PLL_STEP[10]	PLL spread step size control bit 10	R/W	—	—	0
Bit 1	PLL_STEP[9]	PLL spread step size control bit 9	R/W	—	—	0
Bit 0	PLL_STEP[8]	PLL spread step size control bit 8	R/W	—	—	0

### Byte 9: PLL Spread Spectrum Control

Byte 09h	Name	Control Function	Type	0	1	PWD
Bit 7	PLL_STEP[7]	PLL spread step size control bit 7	R/W	—	—	0
Bit 6	PLL_STEP[6]	PLL spread step size control bit 6	R/W	—	—	0
Bit 5	PLL_STEP[5]	PLL spread step size control bit 5	R/W	—	—	0
Bit 4	PLL_STEP[4]	PLL spread step size control bit 4	R/W	—	—	0
Bit 3	PLL_STEP[3]	PLL spread step size control bit 3	R/W	—	—	0
Bit 2	PLL_STEP[2]	PLL spread step size control bit 2	R/W	—	—	0
Bit 1	PLL_STEP[1]	PLL spread step size control bit 1	R/W	—	—	0
Bit 0	PLL_STEP[0]	PLL spread step size control bit 0	R/W	—	—	0

Byte 10: PLL Period Control

Byte 0Ah	Name	Control Function	Type	0	1	PWD
Bit 7	PLL_PERIOD[7]	PLL period control bit 7	R/W	—	—	0
Bit 6	PLL_PERIOD[6]	PLL period control bit 6	R/W	—	—	0
Bit 5	PLL_PERIOD[5]	PLL period control bit 5	R/W	—	—	0
Bit 4	PLL_PERIOD[4]	PLL period control bit 4	R/W	—	—	0
Bit 3	PLL_PERIOD[3]	PLL period control bit 3	R/W	—	—	0
Bit 2	PLL_PERIOD[2]	PLL period control bit 2	R/W	—	—	0
Bit 1	PLL_PERIOD[1]	PLL period control bit 1	R/W	—	—	0
Bit 0	PLL_PERIOD[0]	PLL period control bit 0	R/W	—	—	0

Byte 11: PLL M Divider Setting (Apply to 5X1503S)

Byte 0Bh	Name	Control Function	Type	0	1	PWD
Bit 7	PLL_MDIV1	PLL reference divider 1	R/W	disable M DIV1	bypadd divider (/1)	1
Bit 6	PLL_MDIV2	PLL reference divider 2	R/W	disable M DIV2	bypadd divider (/2)	0
Bit 5	PLL_MDIV[5]	PLL reference divider control bit 5	R/W	3–63, default is 26		0
Bit 4	PLL_MDIV[4]	PLL reference divider control bit 4	R/W			1
Bit 3	PLL_MDIV[3]	PLL reference divider control bit 3	R/W			1
Bit 2	PLL_MDIV[2]	PLL reference divider control bit 2	R/W			0
Bit 1	PLL_MDIV[1]	PLL reference divider control bit 1	R/W			1
Bit 0	PLL_MDIV[0]	PLL reference divider control bit 0	R/W			0

Byte 11: PLL M Divider Setting (Apply to 5X1503/5X1503L)

Byte 0Bh	Name	Control Function	Type	0	1	PWD
Bit 7	PLL_MDIV1	PLL reference divider 1	R/W	disable M DIV1	bypadd divider (/1)	0
Bit 6	PLL_MDIV2	PLL reference divider 2	R/W	disable M DIV2	bypadd divider (/2)	0
Bit 5	PLL_MDIV[5]	PLL reference divider control bit 5	R/W	3–63, default is 26		0
Bit 4	PLL_MDIV[4]	PLL reference divider control bit 4	R/W			1
Bit 3	PLL_MDIV[3]	PLL reference divider control bit 3	R/W			1
Bit 2	PLL_MDIV[2]	PLL reference divider control bit 2	R/W			0
Bit 1	PLL_MDIV[1]	PLL reference divider control bit 1	R/W			1
Bit 0	PLL_MDIV[0]	PLL reference divider control bit 0	R/W			0

Byte 12: PLL Loop R Setting (Apply to 5X1503S)

Byte 0Ch	Name	Control Function	Type	0	1	PWD
Bit 7	PLL_MDIV_Doubler	PLL reference divider - doubler	R/W	disable	enable	0
Bit 6	PLL IREF	PLL CP reference current	R/W	1X	2X	1
Bit 5	PLL_SSEN	PLL spread spectrum enable	R/W	disable	enable	0
Bit 4	PLL_R100K	PLL Loop filter resistor 100kOhm	R/W	bypass	plus 100kOhm	0
Bit 3	PLL_R50K	PLL Loop filter resistor 50kOhm	R/W	bypass	plus 50kOhm	0
Bit 2	PLL_R25K	PLL Loop filter resistor 25kOhm	R/W	bypass	plus 25kOhm	0
Bit 1	PLL_R12.5K	PLL Loop filter resistor 12.5kOhm	R/W	bypass	plus 12.5kOhm	0
Bit 0	PLL_R1K	PLL Loop filter resistor 1kOhm	R/W	bypass	only 1kOhm applied	1

Byte 12: PLL Loop R Setting (Apply to 5X1503/5X1503L)

Byte 0Ch	Name	Control Function	Type	0	1	PWD
Bit 7	PLL_MDIV_Doubler	PLL reference divider - doubler	R/W	disable	enable	0
Bit 6	PLL IREF	PLL CP reference current	R/W	1X	2X	0
Bit 5	PLL_SSEN	PLL spread spectrum enable	R/W	disable	enable	0
Bit 4	PLL_R100K	PLL Loop filter resistor 100kOhm	R/W	bypass	plus 100kOhm	0
Bit 3	PLL_R75K	PLL Loop filter resistor 75kOhm	R/W	bypass	plus 75kOhm	0
Bit 2	PLL_R50K	PLL Loop filter resistor 50kOhm	R/W	bypass	plus 50kOhm	0
Bit 1	PLL_R25K	PLL Loop filter resistor 25kOhm	R/W	bypass	plus 25kOhm	1
Bit 0	PLL_R12.5K	PLL Loop filter resistor 12.5kOhm	R/W	bypass	plus 12.5kOhm	1

Byte 13: PLL Charge Pump Control (Apply to 5X1503S)

Byte 0Dh	Name	Control Function	Type	0	1	PWD
Bit 7	PLL_CP_31X	PLL charge pump control	R/W	—	x31	1
Bit 6	PLL_CP_16X	PLL charge pump control	R/W	—	x16	0
Bit 5	PLL_CP_8X	PLL charge pump control	R/W	—	x8	1
Bit 4	PLL_CP_4X	PLL charge pump control	R/W	—	x4	1
Bit 3	PLL_CP_2X	PLL charge pump control	R/W	—	x2	1
Bit 2	PLL_CP_1X	PLL charge pump control	R/W	—	x1	0
Bit 1	PLL_CP_/24	PLL charge pump control	R/W	—	/24	0
Bit 0	PLL_CP_/3	PLL charge pump control	R/W	—	/3	1

Byte 13: PLL Charge Pump Control (Apply to 5X1503/5X1503L)

Byte 0Dh	Name	Control Function	Type	0	1	PWD
Bit 7	PLL_CP_31X	PLL charge pump control	R/W	—	x31	0
Bit 6	PLL_CP_16X	PLL charge pump control	R/W	—	x16	0
Bit 5	PLL_CP_8X	PLL charge pump control	R/W	—	x8	0
Bit 4	PLL_CP_4X	PLL charge pump control	R/W	—	x4	1
Bit 3	PLL_CP_2X	PLL charge pump control	R/W	—	x2	0
Bit 2	PLL_CP_1X	PLL charge pump control	R/W	—	x1	1
Bit 1	PLL_CP_/24	PLL charge pump control	R/W	—	/24	1
Bit 0	PLL_CP_/3	PLL charge pump control	R/W	—	/3	0

Byte 14: Output Divider1 Control (Apply to 5X1503S)

Byte 0Eh	Name	Control Function	Type	0	1	PWD
Bit 7	OUTDIV1[4]	Output divider1 control bit 4	R/W	DIV1[3:2] = 1,3,5,7,9,11; DIV1[1:0] = 1,2,4,8; DefaultDivider=00001=3		0
Bit 6	OUTDIV1[3]	Output divider1 control bit 3	R/W			1
Bit 5	OUTDIV1[2]	Output divider1 control bit 2	R/W			0
Bit 4	OUTDIV1[1]	Output divider1 control bit 1	R/W			1
Bit 3	OUTDIV1[0]	Output divider1 control bit 0	R/W			0
Bit 2	OUTDIV2 Source Select	OUTDIV2 Source Select	R/W	From REF	OUTDIV2_Source	0
Bit 1	OUTDIV1 Source Select	OUTDIV1 Source Select	R/W	From REF	From PLL	1
Bit 0	OUTDIV1 Seed	OUTDIV1 Seed	R/W	disabled	enable seed to OUTDIV2	0

Byte 14: Output Divider1 Control (Apply to 5X1503/5X1503L)

Byte 0Eh	Name	Control Function	Type	0	1	PWD
Bit 7	OUTDIV1[4]	Output divider1 control bit 4	R/W	DIV1[3:2] = 1,3,5,7,9,11; DIV1[1:0] = 1,2,4,8; DefaultDivider=00001=3		0
Bit 6	OUTDIV1[3]	Output divider1 control bit 3	R/W			0
Bit 5	OUTDIV1[2]	Output divider1 control bit 2	R/W			0
Bit 4	OUTDIV1[1]	Output divider1 control bit 1	R/W			0
Bit 3	OUTDIV1[0]	Output divider1 control bit 0	R/W			1
Bit 2	OUTDIV2 Source Select	OUTDIV2 Source Select	R/W	From REF	OUTDIV2_Source	0
Bit 1	OUTDIV1 Source Select	OUTDIV1 Source Select	R/W	From REF	From PLL	1
Bit 0	OUTDIV1 Seed	OUTDIV1 Seed	R/W	disabled	enable seed to OUTDIV2	0

### Byte 15: Output Divider 2 Control

Byte 0Fh	Name	Control Function	Type	0	1	PWD
Bit 7	OUTDIV2[4]	Output divider2 control bit 4	R/W	DIV1[3:2] = 1, 3, 5, 7, 9, 11; DIV1[1:0] = 1, 2, 4, 8; DefaultDivider=00001=3		0
Bit 6	OUTDIV2[3]	Output divider2 control bit 3	R/W			0
Bit 5	OUTDIV2[2]	Output divider2 control bit 2	R/W			0
Bit 4	OUTDIV2[1]	Output divider2 control bit 1	R/W			0
Bit 3	OUTDIV2[0]	Output divider2 control bit 0	R/W			1
Bit 2	OUT3_OUT_TRI	OUT3 State Select	R/W	normal	Tristate	0
Bit 1	OUT2_OUT_TRI	OUT2 State Select	R/W	normal	Tristate	0
Bit 0	OUT1_OUT_TRI	OUT1 State Select	R/W	normal	Tristate	0

### Byte 16: PLL Operation Control Register

Byte 10h	Name	Control Function	Type	0	1	PWD
Bit 7	OUT1_EN	OUT1 output enable control	R/W	disable	enable	1
Bit 6	OE1_fun_sel[1]	OE1 pin function selection bit 1	R/W	11: DFC0 01: PD#	10: OUT1_PPS 00: OUT1 OE	0
Bit 5	OE1_fun_sel[0]	OE1 pin function selection bit 0	R/W			0
Bit 4	OUT2_EN	OUT2 output enable control	R/W	disable	enable	1
Bit 3	OE2_fun_sel[1]	OE2 pin function selection bit 1	R/W	11: DFC1 01: Config_SEL	10: OUT2_PPS 00: OUT2 OE	0
Bit 2	OE2_fun_sel[0]	OE2 pin function selection bit 0	R/W			0
Bit 1	OUT2 Freerun	OUT2 Freerun enable control	R/W	Freerun	normal	1
Bit 0	OUT1 Freerun	OUT1 Freerun enable control	R/W	Freerun	normal	0

### Byte 17: OE and DFC Control

Byte 11h	Name	Control Function	Type	0	1	PWD
Bit 7	OUT1 CLKSEL 1	OUT1 output clock selection	R/W	00: CLK32K, 10: NA, 11: OUTDIV1	01: OUTDIV2	0
Bit 6	OUT1 CLKSEL 0	OUT1 output clock selection	R/W			0
Bit 5	OUT2 CLKSEL 1	OUT2 output clock selection	R/W	00: CLK32K, 10: NA, 11: OUTDIV1	01: OUTDIV2	1
Bit 4	OUT2 CLKSEL 0	OUT2 output clock selection	R/W			1
Bit 3	OUT3 CLKSEL 1	OUT3 output clock selection	R/W	00: CLK32K, 10: REF, 11: OUTDIV1	01: OUTDIV2	1
Bit 2	OUT3 CLKSEL 0	OUT3 output clock selection	R/W			0
Bit 1	OUT3_EN	OUT3 output enable control	R/W	disable	enable	1
Bit 0	DFC_EN	DFC function control	R/W	disable	enable	0



### Byte 18: Control Register

Byte 12h	Name	Control Function	Type	0	1	PWD
Bit 7	PLL PDB	PLL Powerdown enable control	R/W	Powerdown	Not powerdown	1
Bit 6	PLL LOCKBYPASS	PLL Lock Bypass enable control	R/W	Bypass	Not Bypass	1
Bit 5	SCL HW Mode Sel	SCL in hardware mode function select	R/W	N/A	DFC1	0
Bit 4	PPS PDB EN	PPS PDB enable control	R/W	disable	enable	0
Bit 3	PPS2 Timer_sel<1>	PPS2 Timer select bit 1	R/W	00: 100µs 01: 200µs 10: 400µs 11: 800µs		0
Bit 2	PPS2 Timer_sel<0>	PPS2 Timer select bit 0	R/W			0
Bit 1	PPS1 Timer_sel<1>	PPS1 Timer select bit 1	R/W	00: 100µs 01: 200µs 10: 400µs 11: 800µs		0
Bit 0	PPS1 Timer_sel<0>	PPS1 Timer select bit 0	R/W			0

### Byte 19: Control Register

Byte 13h	Name	Control Function	Type	0	1	PWD
Bit 7	OUT1 CLK Invert	OUT1 CLK Invert control	R/W	Non-Invert	Invert	0
Bit 6	OUT2 CLK Invert	OUT2 CLK Invert control	R/W	Non-Invert	Invert	0
Bit 5	OUT3 CLK Invert	OUT3 CLK Invert control	R/W	Non-Invert	Invert	0
Bit 4	OUT3 Freerun	OUT3 Freerun enable control	R/W	Freerun	normal	1
Bit 3	OUT2 Amp OUT 1	OUT2 Amplitude Select control	R/W	00: 1.8V 01: 1.0V 10: 1.1V 11: 1.0V		0
Bit 2	OUT2 Amp OUT 0	OUT2 Amplitude Select control	R/W			0
Bit 1	OUT3 Amp OUT 1	OUT3 Amplitude Select control	R/W	00: 1.8V 01: 1.0V 10: 1.1V 11: 1.0V		0
Bit 0	OUT3 Amp OUT 0	OUT3 Amplitude Select control	R/W			0

### Byte 20: OUT1 and DIV4 Control (Apply to 5X1503/5X1503S)

Byte 14h	Name	Control Function	Type	0	1	PWD
Bit 7	I2C_PDB	chip power down control bit	R/W	power down	normal	1
Bit 6	Ref_free_run	Reference clock output (OUT2/OUT3)	R/W	stop	freerun	0
Bit 5	free_run_output_config	OUT clocks free run control	R/W	OUT2 free run	OUT2/3 free run	0
Bit 4	PDB Invert	PDB polarity control bit	R/W	Non-Invert	Invert	0
Bit 3	BYP_AC	Bypass AC cap in X1 (5X1503 only)	R/W	normal	Bypass	0
Bit 2	Reserved		R/W	—	—	0
Bit 1	Reserved		R/W	—	—	1
Bit 0	Reserved		R/W	—	—	1

Byte 20: OUT1 and DIV4 Control (Apply to 5X1503L)

Byte 14h	Name	Control Function	Type	0	1	PWD
Bit 7	I2C_PDB	chip power down control bit	R/W	power down	normal	1
Bit 6	Ref_free_run	Reference clock output (OUT2/OUT3)	R/W	stop	freerun	0
Bit 5	free_run_output_config	OUT clocks free run control	R/W	OUT2 free run	OUT2/3 free run	0
Bit 4	PDB Invert	PDB polarity control bit	R/W	Non-Invert	Invert	0
Bit 3	BYP_AC	Bypass AC cap in X1	R/W	normal	Bypass	0
Bit 2	CLK32K Low Drive Amp Select<2:0>	CLK32K Low Drive Amplitude Select<2:0>	R/W	000: 1.8V 001: 0.8V 010: 0.9V 011: 1.0V 100: 1.1V 101:1.2V		0
Bit 1			R/W			1
Bit 0			R/W			1

## Glossary of Features

Table 17. Glossary of Features

Term	Function Description	Apply to
DFC	Dynamic Frequency Control from selected PLL (TBD) to support two VCO frequencies—two different output frequencies by assigning H/W pin state changes (H-L or L-H). Needs to have frequency change Glitch-free function in order to not crash application system.	All
ORT	Overshoot Reduction Technology—when the PLL performs VCO frequency changes by DFC, or manually programming, the VCO changes frequencies smoothly to target frequency without overshoot or undershoot.	All
OE	Output Enable function. High active. Each output can be controlled by assigned OE pin and the dedicated OE pin can be OTP programmable as Global Power Down function (PD#) or Output enable (OE) or proactive power saving function (PPS).	All
PCT	Programmable Calibration Time, for 32K DCO, the programmable calibration time will help power saving or output accuracy adjustments.	All
Glitch-free	The output clock should not have short pulses that will kill the application system, the output frequency switch (based on DFC) should has glitch free function.	All
SS	Spread Spectrum Clock	5X1503S
PPS	Proactive Power Saving. Utilizes OE pin as monitor pin for end device X2 clock status. See <a href="#">PPS – Proactive Power Saving Function</a> description for details.	All

## Package Outline Drawings

The package outline drawings are appended at the end of this document and are accessible from the link below. The package information is the most current data available.

[www.idt.com/document/psc/10-vfqfpn-package-outline-drawing-20-x-20-x-10-mm-body-epad-16-x-08-mm-04mm-pitch-nlg10p1](http://www.idt.com/document/psc/10-vfqfpn-package-outline-drawing-20-x-20-x-10-mm-body-epad-16-x-08-mm-04mm-pitch-nlg10p1)

## Ordering Information

Orderable Part Number	Package	Shipping Packaging	Temperature
5X1503-xxxNLGI	2.0 × 2.0 × 1.0 mm 10-VFQFPN	Tray	-40° to +85°C
5X1503-xxxNLGI8	2.0 × 2.0 × 1.0 mm 10-VFQFPN	Reel	-40° to +85°C
5X1503L-xxxNLGI	2.0 × 2.0 × 1.0 mm 10-VFQFPN	Tray	-40° to +85°C
5X1503L-xxxNLGI8	2.0 × 2.0 × 1.0 mm 10-VFQFPN	Reel	-40° to +85°C
5X1503S-xxxNLGI	2.0 × 2.0 × 1.0 mm 10-VFQFPN	Tray	-40° to +85°C
5X1503S-xxxNLGI8	2.0 × 2.0 × 1.0 mm 10-VFQFPN	Reel	-40° to +85°C

## Marking Diagrams

5X1503

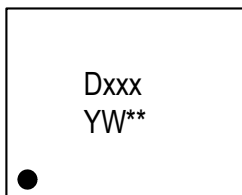

- Line 1 is the truncated part number and indicates the following:
  - “D” denotes 5X1503; “xxx” denotes dash code.
  - “E” denotes 5X1503L; “xxx” denotes dash code.
  - “F” denotes 5X1503S; “xxx” denotes dash code.
- Line 2 indicates the following:
  - “YW” is the last digit of the year and work week the part was assembled.
  - “\*\*” denotes sequential lot number.

5X1503L

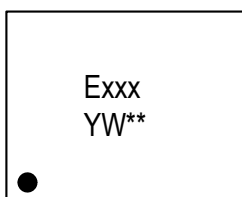

5X1503S

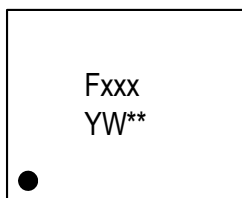

---

## Revision History

Revision Date	Description of Change
June 19, 2019	Initial release.

## IMPORTANT NOTICE AND DISCLAIMER

RENESAS ELECTRONICS CORPORATION AND ITS SUBSIDIARIES (“RENESAS”) PROVIDES TECHNICAL SPECIFICATIONS AND RELIABILITY DATA (INCLUDING DATASHEETS), DESIGN RESOURCES (INCLUDING REFERENCE DESIGNS), APPLICATION OR OTHER DESIGN ADVICE, WEB TOOLS, SAFETY INFORMATION, AND OTHER RESOURCES “AS IS” AND WITH ALL FAULTS, AND DISCLAIMS ALL WARRANTIES, EXPRESS OR IMPLIED, INCLUDING, WITHOUT LIMITATION, ANY IMPLIED WARRANTIES OF MERCHANTABILITY, FITNESS FOR A PARTICULAR PURPOSE, OR NON-INFRINGEMENT OF THIRD PARTY INTELLECTUAL PROPERTY RIGHTS.

These resources are intended for developers skilled in the art designing with Renesas products. You are solely responsible for (1) selecting the appropriate products for your application, (2) designing, validating, and testing your application, and (3) ensuring your application meets applicable standards, and any other safety, security, or other requirements. These resources are subject to change without notice. Renesas grants you permission to use these resources only for development of an application that uses Renesas products. Other reproduction or use of these resources is strictly prohibited. No license is granted to any other Renesas intellectual property or to any third party intellectual property. Renesas disclaims responsibility for, and you will fully indemnify Renesas and its representatives against, any claims, damages, costs, losses, or liabilities arising out of your use of these resources. Renesas' products are provided only subject to Renesas' Terms and Conditions of Sale or other applicable terms agreed to in writing. No use of any Renesas resources expands or otherwise alters any applicable warranties or warranty disclaimers for these products.

(Disclaimer Rev.1.0 Mar 2020)

### Corporate Headquarters

TOYOSU FORESIA, 3-2-24 Toyosu,  
Koto-ku, Tokyo 135-0061, Japan  
[www.renesas.com](http://www.renesas.com)

### Contact Information

For further information on a product, technology, the most up-to-date version of a document, or your nearest sales office, please visit:  
[www.renesas.com/contact/](http://www.renesas.com/contact/)

### Trademarks

Renesas and the Renesas logo are trademarks of Renesas Electronics Corporation. All trademarks and registered trademarks are the property of their respective owners.