

Customer Information Sheet

DRAWING No.: KF-465/466/4670006 SHEET 2 OF 2 IF IN DOUBT - ASK (C) NOT TO SCALE THIRD ANGLE PROJECTION ALL DIMENSIONS IN mm

ORDER CODE:
KF-46X0006
 SERIES CODE
 (SEE TABLE)

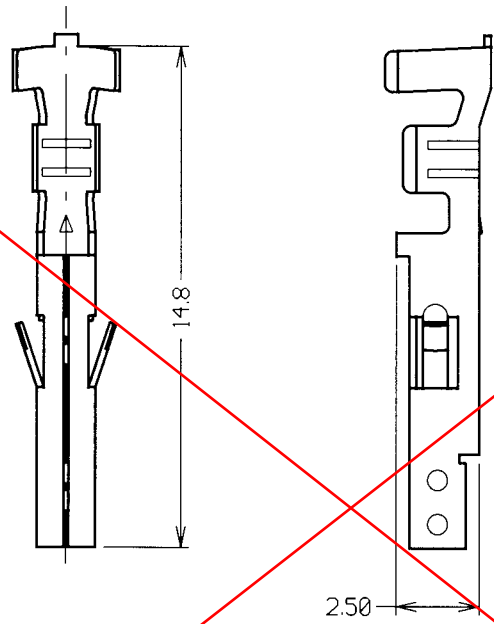

OBSOLETE

HARWIN PART NUMBER	CRIMP PULL-OFF FORCE	WIRE SIZE
KF-4650006	88N MIN	16-20 AWG
KF-4660006	39N MIN	22-24 AWG
KF-4670006	9N MIN	26-28 AWG

- NOTES:
- FOR USE WITH CRIMP HOUSING KF-470XX00. RELEVANT SPECIFICATIONS ARE QUOTED ON THE CRIMP HOUSING DRAWING. FOR COMPLETE SPECIFICATION, SEE COMPONENT SPECIFICATION C033XX (LATEST ISSUE).
 - QUANTITY PER BAG = 100.

DATE	ISS.	DATE	C/NOTE
01.08.03	2		7538
APPROVED: <i>[Signature]</i>			
CHECKED: <i>[Signature]</i>			
DRAWN: W. J. BOURNE			
CUSTOMER REF.:			
ASSEMBLY DRG.:			



HARWIN INC U.S.A. TEL: (812) 542 2546 FAX: (812) 542 2541	HARWIN PLC U.K. TEL: 023 9237 0451 FAX: 023 9231 4590	HARWIN PTE SINGAPORE TEL: 65 6779 4909 FAX: 65 6779 3868
--	--	---

THIS DRAWING AND ANY INFORMATION OR DESCRIPTIVE MATTER SET OUT HEREON ARE CONFIDENTIAL AND COPYRIGHT PROPERTY OF THE HARWIN GROUP AND MUST NOT BE DISCLOSED, LOANED, COPIED OR USED FOR MANUFACTURING, TENDERING OR FOR ANY OTHER PURPOSE WITHOUT THEIR WRITTEN PERMISSION.

TOLERANCES
 X - ±1mm
 X.X - ±0.25mm
 X.XX - ±0.10mm
 X.XXX - ±0.01mm
 ANGLES - ±5°
 UNLESS STATED

MATERIAL:
 BRASS
 FINISH: 0.5μ NICKEL, 2.0μ TIN
 S/AREA: mm²

TITLE:
 POWERFIT®
 4.2mm PITCH FEMALE
 CRIMP SOCKET (LOOSE)
 DRAWING NUMBER:
KF-465/466/4670006
 SHT 2 OF 2

Customer Information Sheet

DRAWING No.: KF-4660046 SHEET 2 OF 2 IF IN DOUBT - ASK © NOT TO SCALE THIRD ANGLE PROJECTION ALL DIMENSIONS IN mm

OBSOLETE

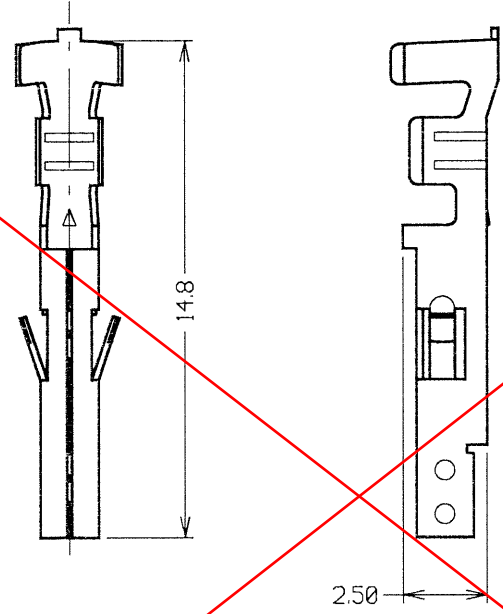

- NOTES:
1. FOR USE WITH WIRE SIZE 22-24 AWG.
 2. CRIMP PULL-OFF FORCE = 39N MIN.
 3. USE WITH CRIMP HOUSING KF-4700200 & KF-4700300. FOR COMPLETE SPECIFICATION SEE COMPONENT SPEC. C033XX (LATEST ISSUE).
 4. FINISH: 2.0µ 100% TIN OVER 0.5µ NICKEL.
 5. QUANTITY PER BAG = 100.

JMB	1	26.07.06	9349
NAME	ISS.	DATE	C/NOTE
APPROVED: <i>[Signature]</i>			
CHECKED: <i>[Signature]</i>			
DRAWN: JM BROOKES		CUSTOMER REF.:	
ASSEMBLY DRG:			

HARWIN

HARWIN USA TEL: 603 893 5376 FAX: 603 893 5396 mis@harwin.com	HARWIN Europe (UK) TEL: 023 9231 4545 FAX: 023 9231 4590 mis@harwin.co.uk	HARWIN Asia TEL: +65 6 779 4909 FAX: +65 6 779 3868 mis@harwin.com.sg
--	--	--

THIS DRAWING AND ANY INFORMATION OR DESCRIPTIVE MATTER SET OUT HEREON ARE CONFIDENTIAL AND COPYRIGHT PROPERTY OF THE HARWIN GROUP AND MUST NOT BE DISCLOSED, LOANED, COPIED OR USED FOR MANUFACTURING, TENDERING OR FOR ANY OTHER PURPOSE WITHOUT THEIR WRITTEN PERMISSION.

TOLERANCES
 X. = ±1mm
 X.X = ±0.25mm
 X.XX = ±0.10mm
 X.XXX = ±0.01mm
 ANGLES = +5°
 UNLESS STATED

MATERIAL: BRASS
 FINISH: SEE NOTE 4
 S/AREA: mm²

TITLE: POWERFIT®
 4.2mm PITCH FEMALE
 CRIMP SOCKET (LOOSE)
 DRAWING NUMBER: KF-4660046
 SHT 2 OF 2