

NUT

NOTE:

MATERIAL	
HOUSING:	PBT UL94V-0, BLACK
CONTACT:	BRASS
NUT:	BRASS
SHELL:	BRASS
O-RING:	EPDM
FINISH	
CONTACT:	GOLD PLATED OVER 50µ" NICKEL
NUT:	NICKEL PLATED
SHELL:	NICKEL PLATED
ELECTRICAL	
RATED CURRENT:	4A
RATED VOLTAGE:	250V
INSULATION RESISTANCE:	100 MΩhms MIN.
CONTACT RESISTANCE:	10 mΩhms MAX.
WATER PROOF:	IP67
ENVIRONMENT	
OPERATION TEMPERATURE:	-40°C TO +85°C
MAX WIRE AWG:	22

858-003-203RLSY

3 = BRASS/NICKEL (B/N) SHELL & NUT
 S = STAINLESS STEEL (SS) SHELL & NUT
 T = B/N SHELL / SS NUT

1 = GOLD FLASH
 4 = 10µ" GOLD

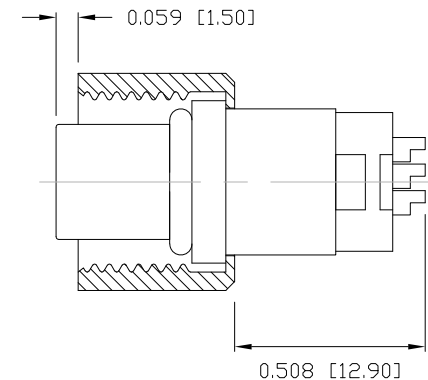
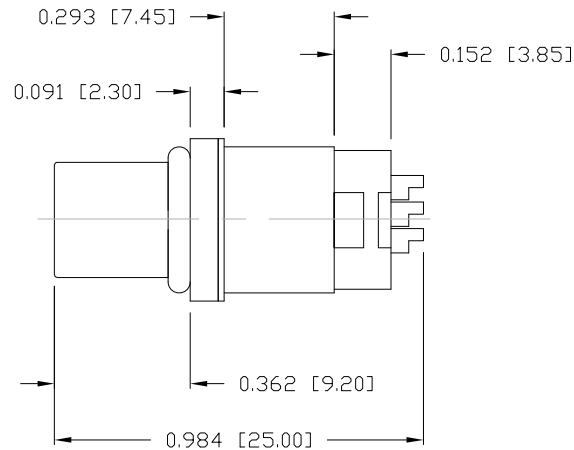
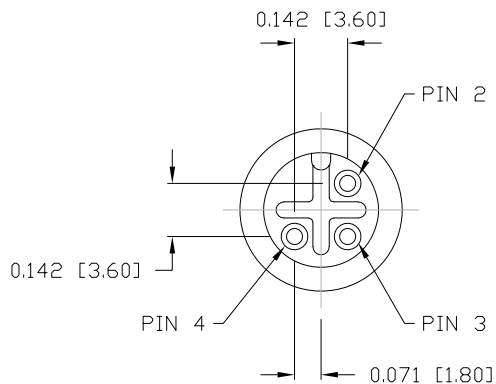

RoHS COMPLIANT

UNITS = inch [mm]

DO NOT SCALE FROM DRAWING



THESE DRAWINGS AND SPECIFICATIONS ARE THE PROPERTY OF NorComp AND SHALL NOT BE REPRODUCED, COPIED OR USED AS THE BASIS FOR THE MANUFACTURE OR SALE OF APPARATUS WITHOUT WRITTEN PERMISSION.

DRAWN: M. SIGMON

DATE: 03-07-16

NorComp

SCALE: NTS

SHEET 1 OF 1

REV 4

DWG NO.

858-003-203RLSY