

THIS DRAWING IS UNPUBLISHED. RELEASED FOR PUBLICATION
 © COPYRIGHT BY TYCO ELECTRONICS CORPORATION. ALL RIGHTS RESERVED.

LOC		DIST		REVISIONS			
P	LTR	DESCRIPTION		DATE	DWN	APVD	
GP	00	G		REVISED PER ECO-08-007327	17APR08	BM WM	

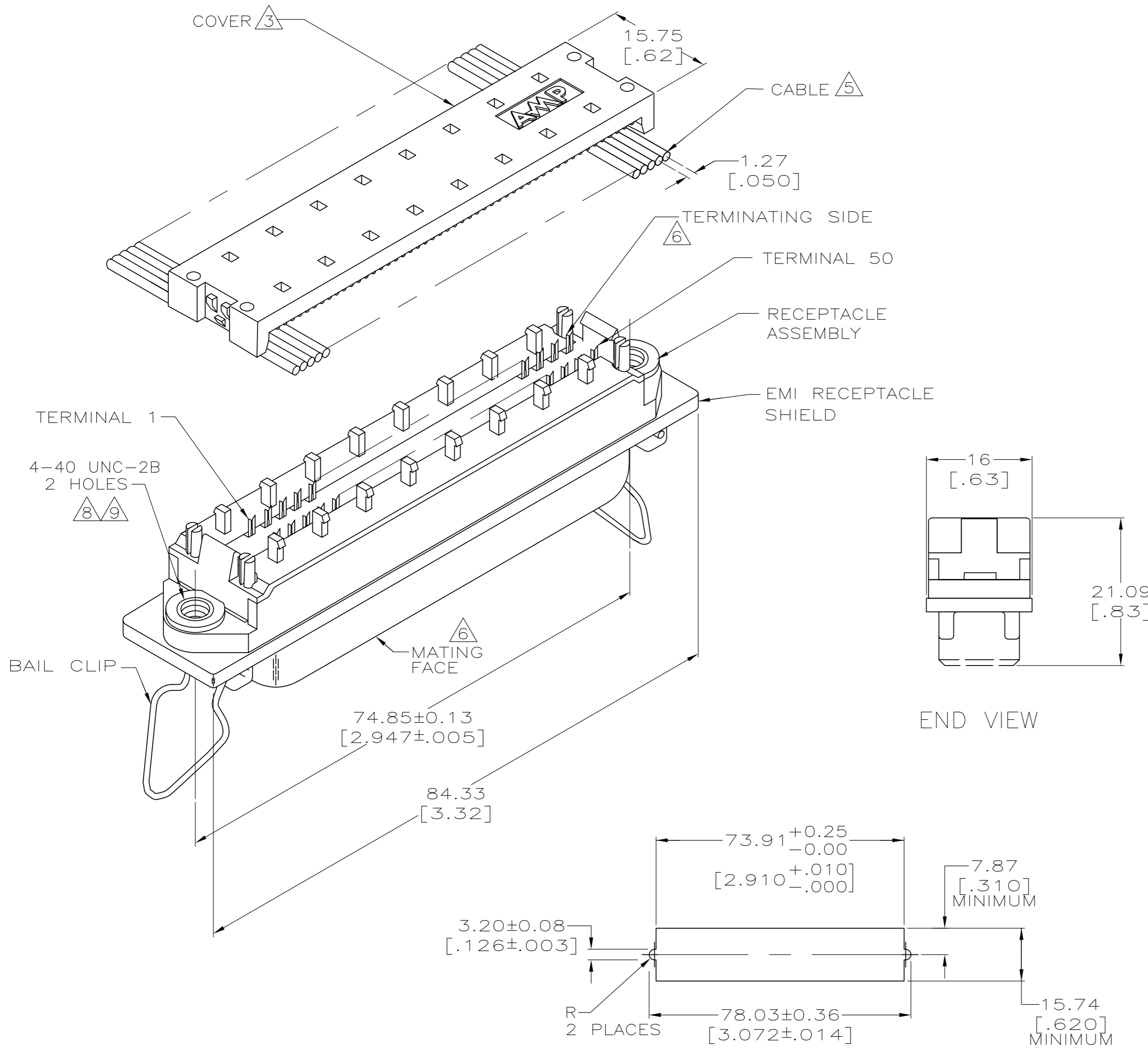

1. THE CONTACT SURFACES OF THE TERMINALS ARE COATED WITH LUBRICANT.
2. MATERIAL:
HOUSING & COVER – POLYPHENYLENE OXIDE (BLACK).
TERMINALS – PHOS BRONZE PLATED WITH EITHER 0.76µm [.000030] MINIMUM GOLD PLATE OR GOLD FLASH OVER PALLADIUM NICKEL PLATE, 0.76µm [.000030] MIN TOTAL ON MATING SURFACE. GOLD FLASH PLATED ON TERMINATING SIDE. 1.27µm [.000050] MINIMUM NICKEL UNDERPLATE OVER ENTIRE TERMINAL.
EMI SHIELD – NICKEL PLATED DIE CASTING.
BAIL CLIPS – PASSIVATED STAINLESS STEEL.
3. COVER SHOWN LOOSE BUT SHIPPED ASSEMBLED.
4. WIRE RANGE: 26 AWG SOLID THRU 30 AWG SOLID AND 28 AWG STRANDED RIBBON CABLE.
5. FLAT CABLE SHALL BE FURNISHED BY CUSTOMER.
6. MATING FACE CONSISTS OF TWO ROWS OF TERMINALS ON 2.16 [.085] CENTERS. TERMINATING SIDE CONSISTS OF TERMINALS ON 2.54 [.100] CENTERS FOR AN EFFECTIVE 1.27 [.050] TERMINATION.
7. PANEL THICKNESS RANGE: 1.58 [.062] MAXIMUM.
8. HOLES ARE TAPPED AFTER PLATING.
9. MINOR CRACKS ALLOWED ON POST DUE TO FORMING. SHIELD RETENTION TO ASSEMBLY: 20.41kg [45lb].
10. ALL DIMENSIONS SHOWN ARE MAXIMUM UNLESS OTHERWISE SPECIFIED.

END VIEW

SUGGESTED PANEL CUTOUT FOR SCREWLOCK FEATURE (7)
 SCALE 1:1

THIS DRAWING IS A CONTROLLED DOCUMENT.		DWN K. TILLMAN/JTA 12-16-93	Tyco Electronics Corporation Harrisburg, PA 17105-3608	
DIMENSIONS: mm [INCHES]		CHK C. WHITT 9-1-94	NAME EMI RECEPTACLE ASSEMBLY, 50 POSITION, LOW PROFILE, SHIELDED, BAIL LOCK,	
TOLERANCES UNLESS OTHERWISE SPECIFIED: 0 PLC ± - 1 PLC ± - 2 PLC ± - (10) 3 PLC ± - 4 PLC ± - ANGLES ± - FINISH (2)		APVD J. HARRIS 9-8-94	PRODUCT SPEC 108-6076	RESTRICTED TO
MATERIAL (2)		APPLICATION SPEC 114-6030	SIZE A2	SCALE 2:1
		WEIGHT -	CAGE CODE 00779	SHEET 1 OF 1
		CUSTOMER DRAWING	DRAWING NO C=554902	REV G

554902-1
 PART NO