

COVER NOT SHOWN

M4 THREADED INERT X 4

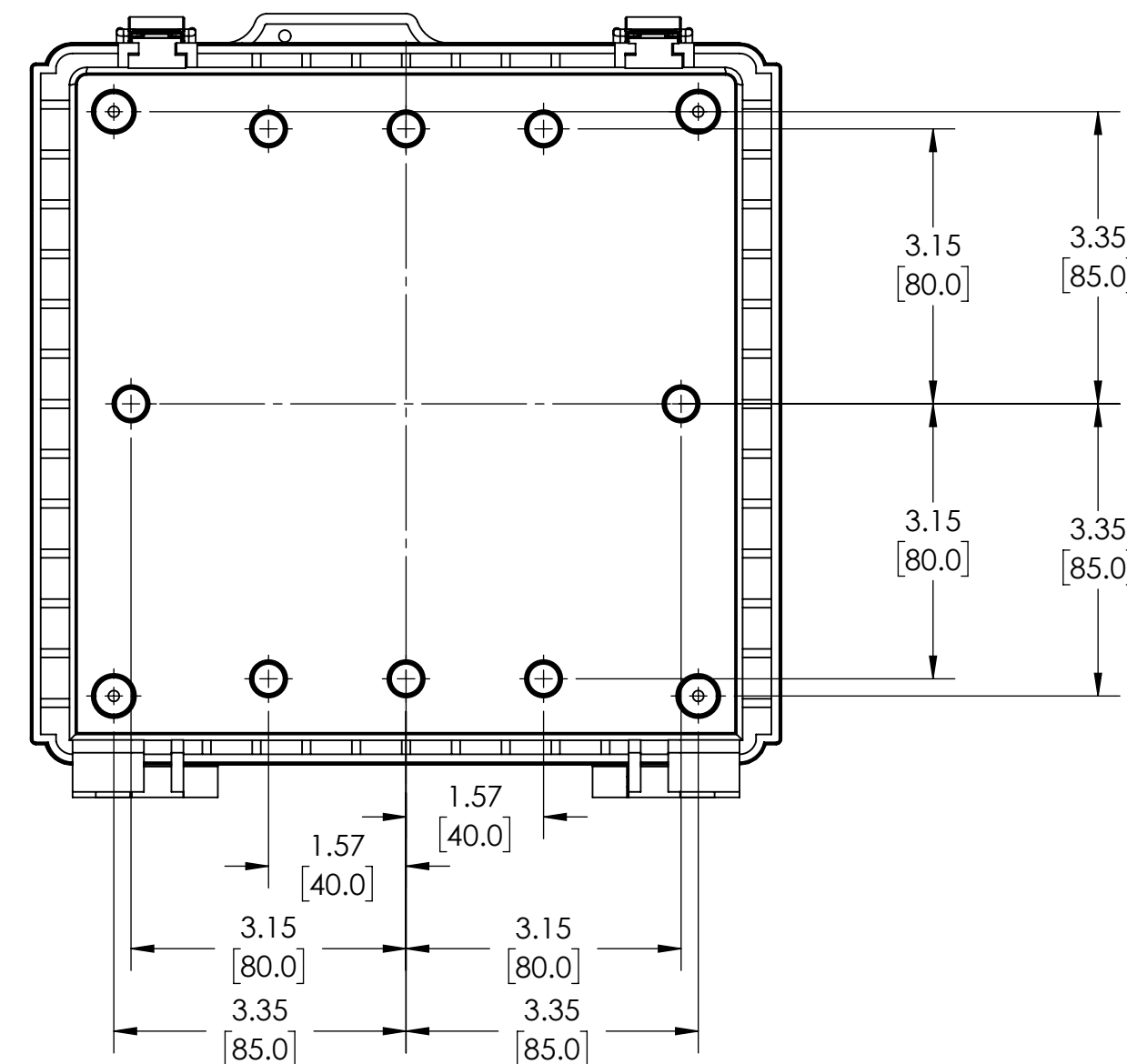
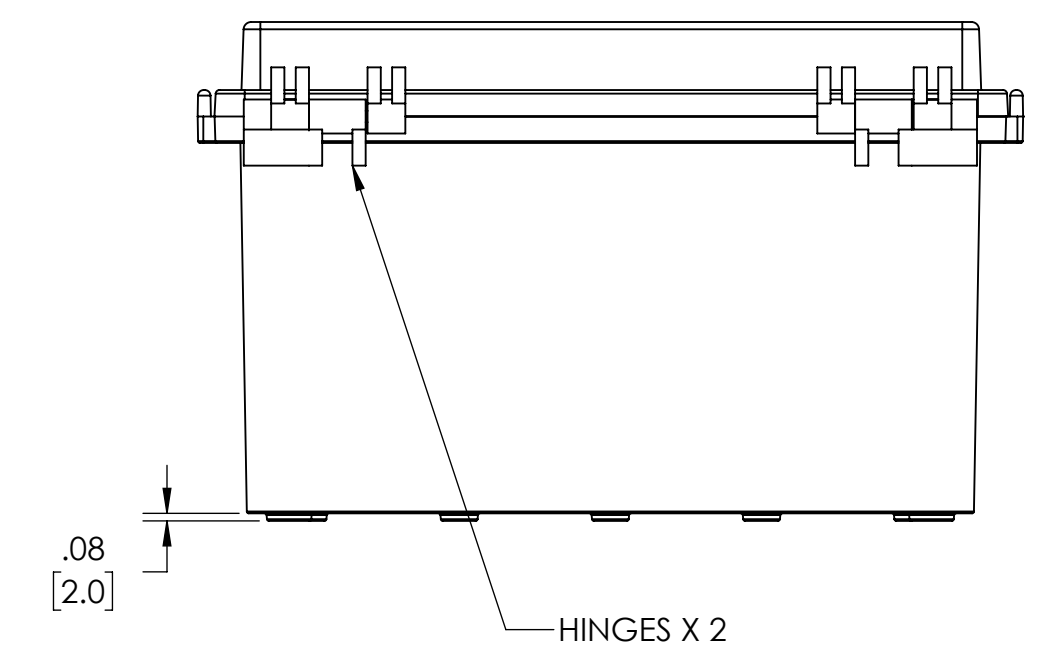
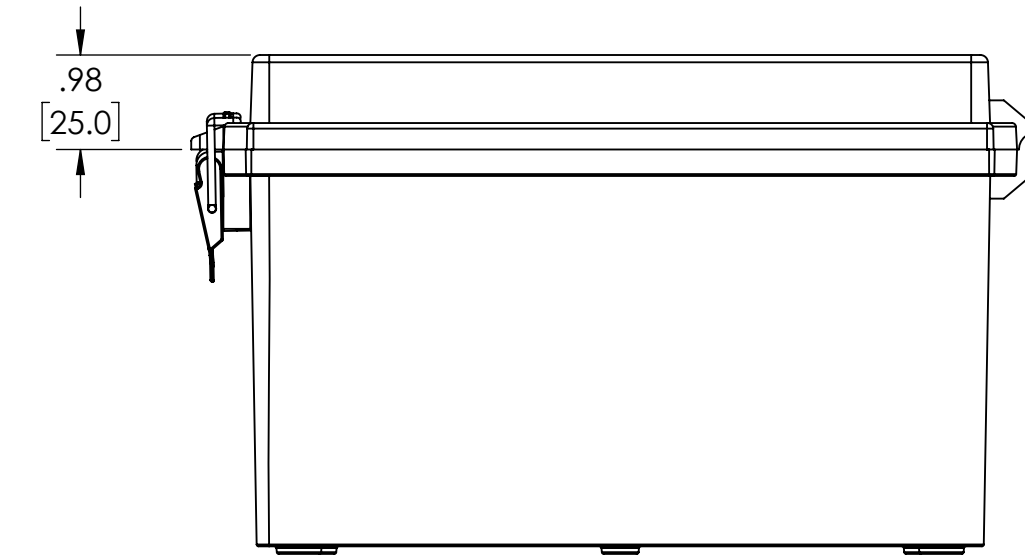
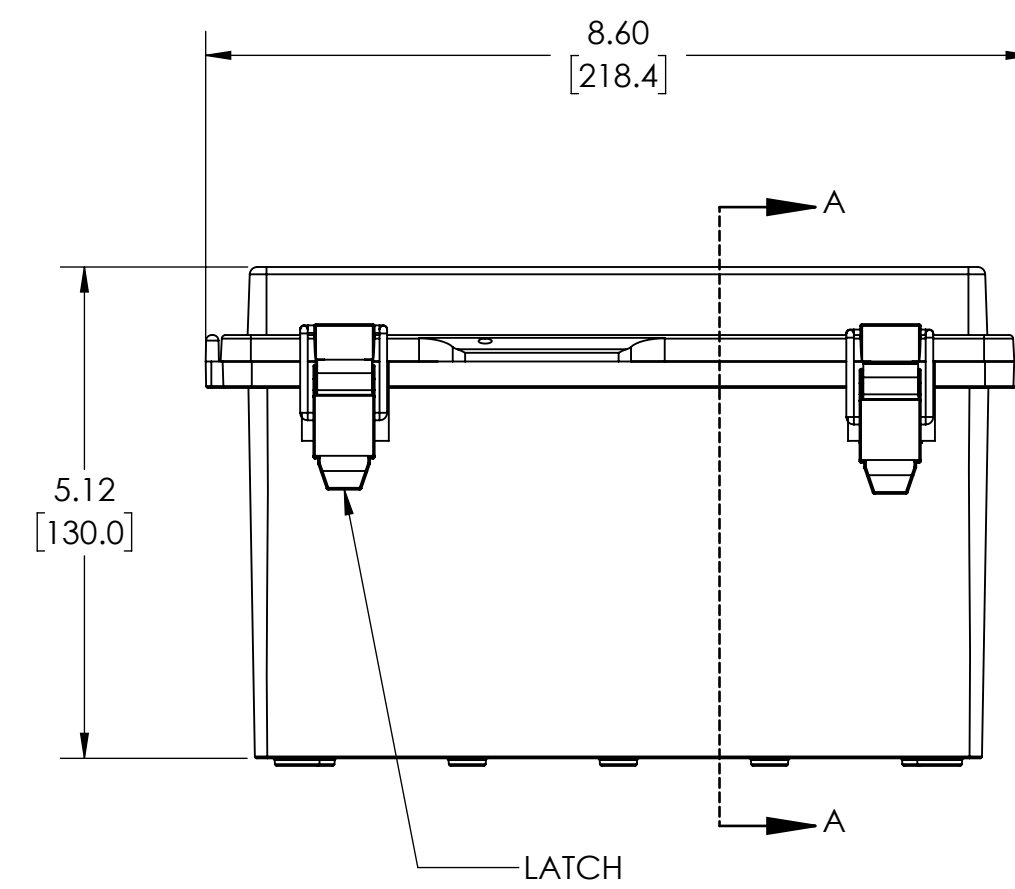
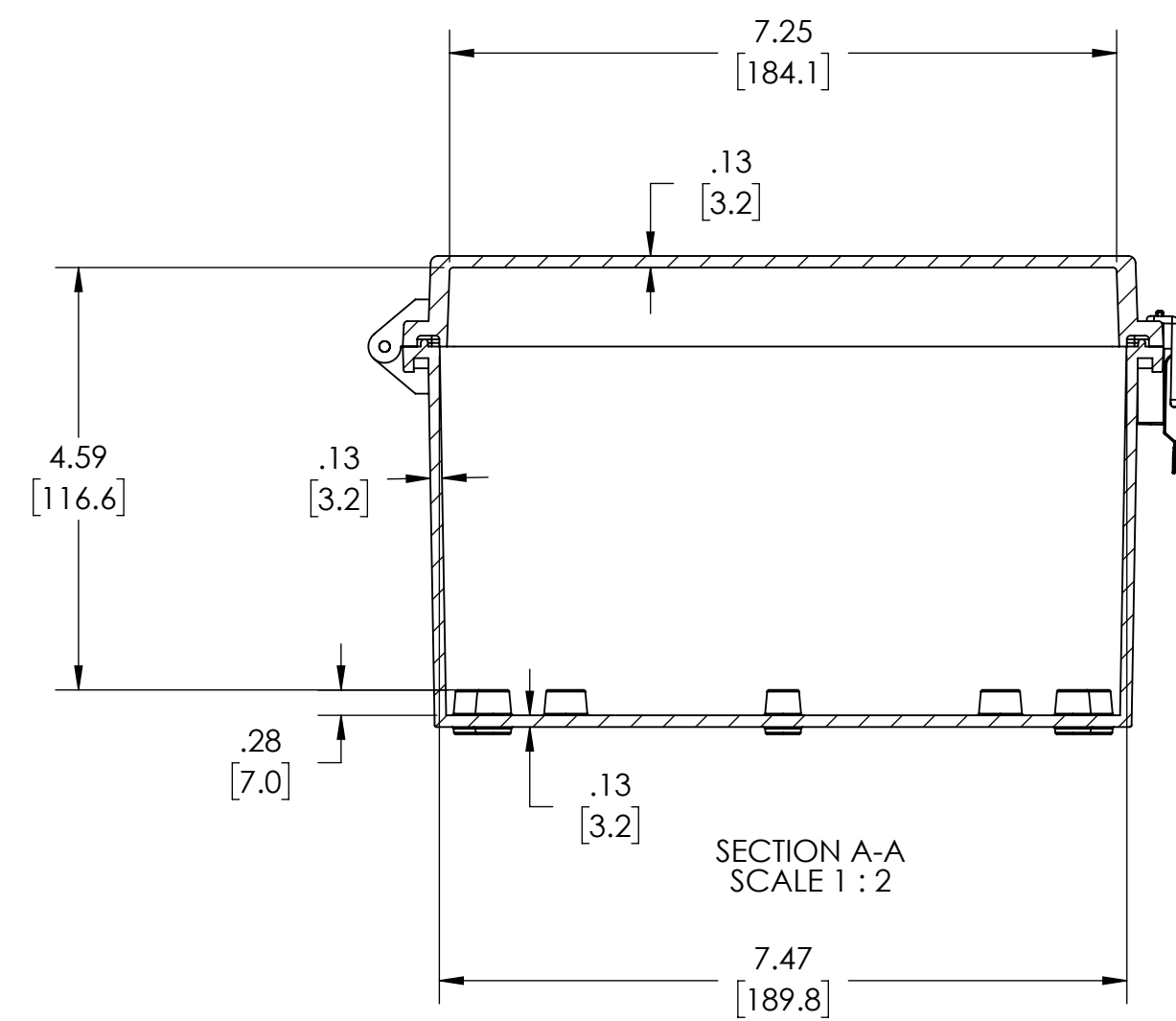

NOTES:

- MATERIAL: BODY - POLYCARBONATE 10% FIBERGLASS REINFORCED
COVER - POLYCARBONATE
UL508 /NEMA TYPE 4X WITH IP-67 TUV RATING & UL-94V0 RATING
- FINISH: BODY - LIGHT GRAY
COVER - LIGHT GRAY OR CLEAR (-C)
- CONTINUOUS GASKET IN COVER
- SUPPLIED WITH FOUR M4 x 8mm LG. TRUSS HEAD MACHINE SCREWS
- DIMENSIONS ARE INCH [MM]
- OPTIONAL ACCESSORIES:
INTERNAL STEEL PANEL - #
INTERNAL PLASTIC PANEL - #
MOUNTING BRACKET KIT (STAINLESS STEEL) - #

DRAWING FOR REFERENCE
WE RESERVE THE RIGHT TO MAKE CHANGES TO OUR
STANDARD PRODUCTS. PLEASE CONSULT WITH BUD INDUSTRIES
PRIOR TO USING THIS DRAWING FOR DESIGN PURPOSE.