

QUICK START GUIDE FOR DEMONSTRATION CIRCUIT DC567

USB BATTERY CHARGER

LTC4410/LTC4053

DESCRIPTION

Demonstration circuit DC567 shows how to use the LTC[®]4410 USB power manager IC in conjunction with a battery charger IC, in this case the LTC4053, to charge a battery from the USB cable.

Design files for this circuit board are available. Call the LTC factory.

LTC is a registered trademark of Linear Technology Corporation

OPERATING PRINCIPLES

DC567 achieves USB compliant battery charging by measuring the current to the USB application circuit and reducing the charging current in order to hold the input current within the USB specification. Connected to the demo board will be a single Li-Ion cell, a source of charging power and an application load. Battery charging is controlled by the LTC4053, which is a constant current, constant voltage, timer terminated single Li-Ion charger. The LTC4053 also features a die temperature limit to avoid excessive

PCB temperatures. USB compliance is achieved by the LTC4410, which measures the current flowing from the USB power input into the application load and backs off the charge current in a 1:1 ratio to maintain compliant input current. The LTC4410 also provides power path management and in the event the USB power is not present, connects the Li-Ion battery to the application load via a low loss Mosfet in order to maximize battery run time.

QUICK START PROCEDURE

Demonstration circuit 567 is easy to set up to evaluate the performance of the LTC4410/LTC4053.

LTC4053 Charger Function

1. Place the Charger Enable Jumper in the ON position.
2. Place the Mode jumper in the 500mA position.
3. Connect the input supply, USB load resistor, meters and simulated battery as shown in Figure 1.

4. Turn on the power at the input.

NOTE: Make sure that the input voltage does not exceed 6V.

5. Turn on the simulated battery power supply and set the voltage to 0V.
6. Note trickle charge current of approximately 45mA.
7. Increase the voltage of the simulated battery. As the battery voltage reaches 2.7V the charge current should increase to 440mA.

8. To simulate an over-temperature condition, connect a 2k resistor between the NTC pin and ground. Charging should stop and the Fault LED will light up.
9. Continue to increase the battery voltage. As the battery voltage reaches 4.2V the charge current will rapidly diminish. As the charge current falls under 45mA the Charging LED will go out.

USB Power Manager Function

USB 500mA mode

10. Connect a 0-500mA load to the terminals designated USB device. This simulates the actual application load.
11. Reduce the battery voltage to about 3.6V so that normal charging is resumed.
12. Increase the USB application load current from 0mA to 500mA and note that as the application load current increases the battery charging

current decreases, so that the input current drawn from the USB cable remains constant.

USB Suspend Mode

13. Move the Charger Enable Jumper to OFF
14. Verify that the Mode jumper is in the 500mA position
15. Set the current draw of any USB Device load to zero
16. Note that the input current to the demo board is less than 200uA, which complies with the USB suspend mode spec.

USB Low power Mode

17. Re-enable the charger by placing the Charger Enable jumper in the ON position.
18. Move the Mode jumper to 100mA.

19. Increase the USB application load from 0 - 100mA and note that as the application current increases the charge current decreases in such a way as to maintain the input current under 100mA.

Battery Powered Operation

20. Turn off the input supply and note that the USB load is now supplied from the battery. Note also the voltage drop from the battery to the load is small due to the use of a Mosfet to switch the battery to the load.

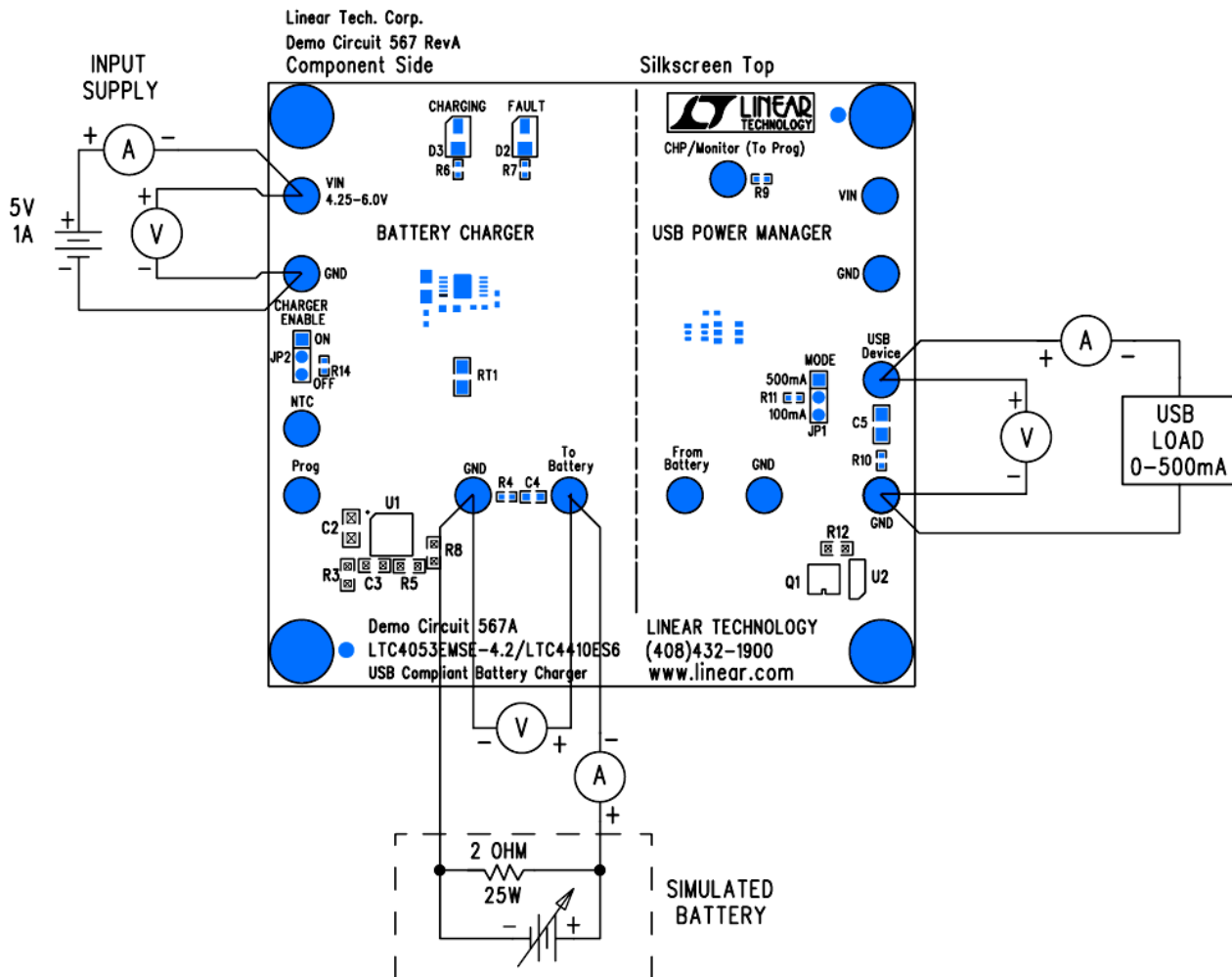
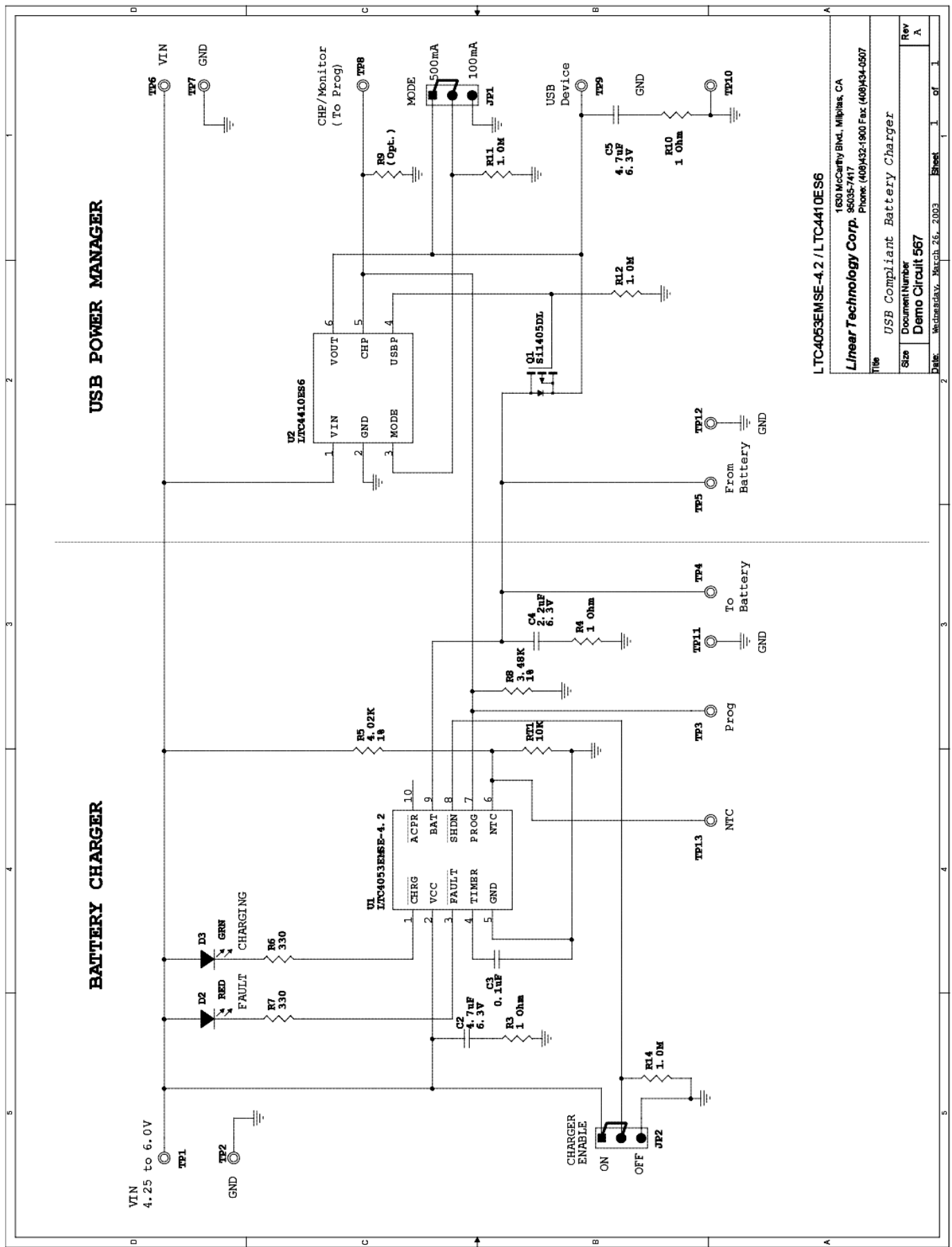

Figure 1. Proper Measurement Equipment Setup

QUICK START GUIDE FOR DEMONSTRATION CIRCUIT DC567

USB BATTERY CHARGER



LTC4053EMSE-4.2 / LTC4410ES6

1630 McCarthy Blvd., Milpitas, CA
Linear Technology Corp. 95035-7417
 Phone: (408)432-1900 Fax: (408)434-0507

Title		USB Compliant Battery Charger	
Size	Document Number	Demo Circuit 567	
Rev		Sheet	1 of 1
A		Date:	Wednesday, March 26, 2003

BATTERY CHARGER

USB POWER MANAGER

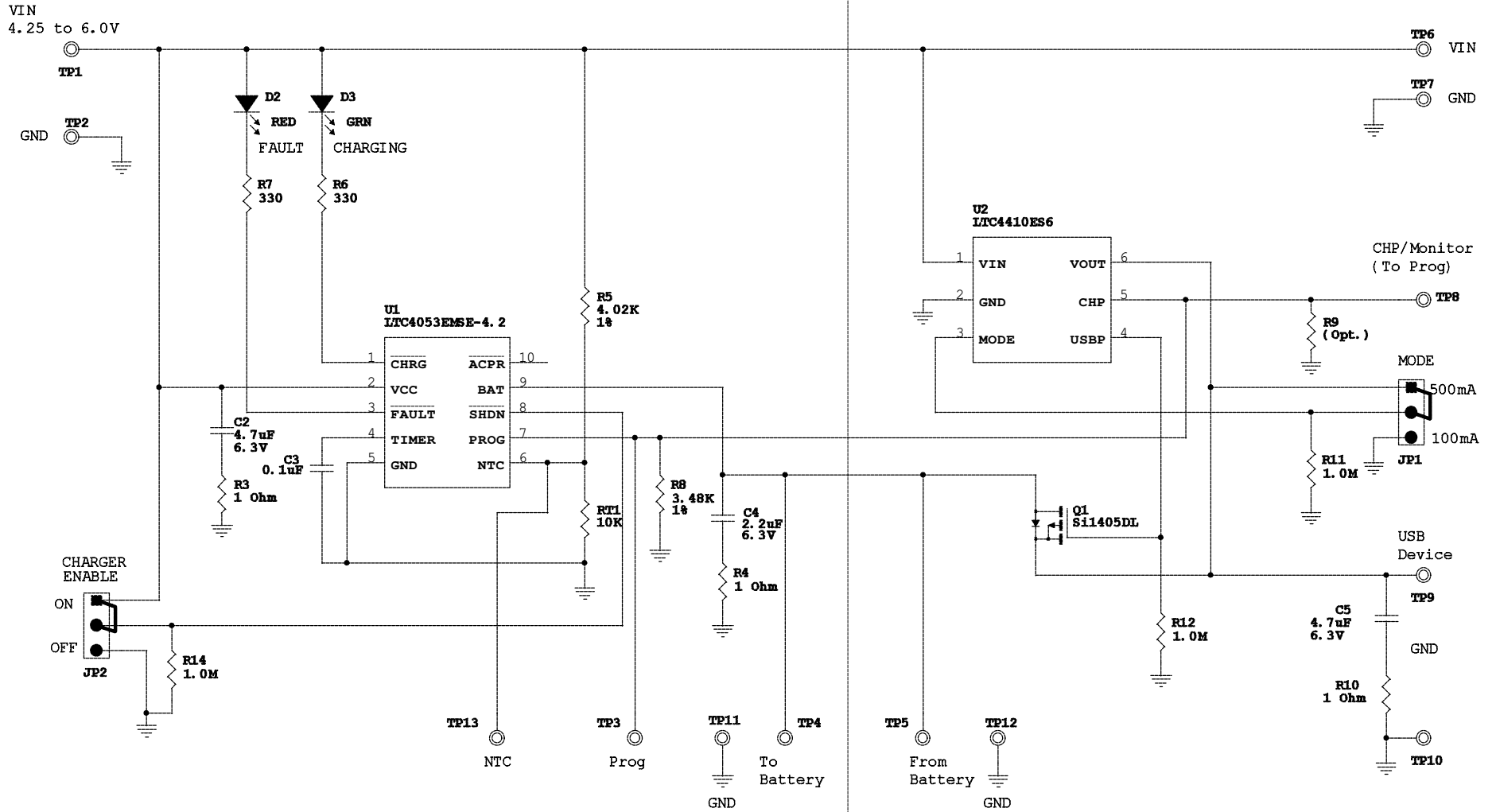

LTC4053EMSE-4.2 / LTC4410ES6

Linear Technology Corp. 1630 McCarthy Blvd., Milpitas, CA 95035-7417 Phone: (408)432-1900 Fax (408)434-0507	
Title <i>USB Compliant Battery Charger</i>	
Size Demo Circuit 567	Document Number Demo Circuit 567
Date: Wednesday, March 26, 2003	Sheet 1 of 1
	Rev A

6/17/2005

Item	Qty	Reference	Part Description	Manufacture / Part #
1	2	C2,C5	Cap., X5R 4.7uF 6.3V 20%	Taiyo Yuden JMK212BJ475MG-T
2	1	C3	Cap., X7R 0.1uF 16V 20%	Taiyo Yuden EMK107BJ104MA
3	1	C4	Cap., X5R 2.2uF 6.3V 10%	Taiyo Yuden JMK107BJ225KA-T
4	1	D2	LED, RED	Panasonic LN1251-C-TR
5	1	D3	LED, GRN	Panasonic LN1351-C-TR
6	2	JP2,JP1	Headers, 3 Pins 2mm Ctrs.	CommConn Con Inc. 2802S-03G2
7	2	XJP1,XJP2	Shunt, 2 Pins 2mm Ctrs.	CommConn Con Inc. CCIJ2MM-138G
8	1	Q1	Mosfet P-Chan., 1.8V	Vishay Siliconix Si1405DL
9	1	RT1	Res., Chip 10K	AAC CR10-103JM
10	3	R3,R4,R10	Res., Chip 1 Ohm 0.06W 5%	AAC CR05-1R0JM
11	1	R5	Res., Chip 4.02K 1/16W 1%	AAC CR05-4021FM
12	2	R7,R6	Res., Chip 330 1/16W 5%	AAC CR05-331JM
13	1	R8	Res., Chip 3.48K 1/16W 1%	AAC CR05-3481FM
14	0	R9 (Opt.)	Res., Chip 3.48K 1/16W 1%	AAC CR05-3481FM
15	3	R11,R12,R14	Res., Chip 1.0M 1/16W 5%	AAC CR05-105JM
16	13	TP1-TP13	Turret, Testpoint	Mill Max 2501-2
17	1	U1	I.C., Batt. Charger Controller	Linear Tech. Corp. LTC4053EMSE-4.2
18	1	U2	I.C., XXXXXX	Linear Tech. Corp. LTC4410ES6
19	4		SCREW, #4-40, 1/4"	ANY
20	4		STANDOFF, #4-40 1/4"	MICRO PLASTICS 14HTSP101
21	1		PRINTED CIRCUIT BOARD	DEMO CIRCUIT 567A
22	1		STENCIL	STENCIL DC567A