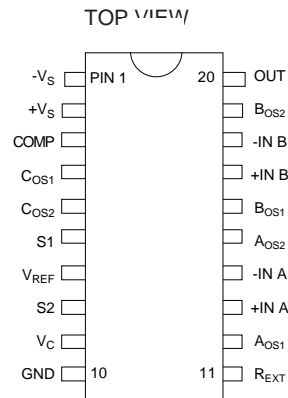

FEATURES

- broadcast quality video multiplier
- 30 MHz at -1.0 dB video and control channel bandwidth
- one external frequency compensation adjustment
- ultra low differential gain and differential phase, (typically 0.01 % and 0.01 deg.)
- external DC offset and span trims
- 20 pin PDIP and SOIC packaging

APPLICATIONS

- Production switcher video mixers
- Linear Keyers

PIN CONNECTIONS

20 PIN DIP / SOIC

PIN DESIGNATION

- | | | |
|----|-----------------|-------------------------------|
| 1 | -V _S | negative supply voltage |
| 2 | +V _S | positive supply voltage |
| 3 | COMP | output freq'y comp'n R-C |
| 4 | C OS1 | control input offset adjust |
| 5 | C OS2 | control input offset adjust |
| 6 | S1 | span adjust |
| 7 | V REF | 0.5volt reference input |
| 8 | S2 | span adjust |
| 9 | V _C | control signal input |
| 10 | GND | ground |
| 11 | R EXT | current setting resistor |
| 12 | A OS1 | A black level adjust (OFFSET) |
| 13 | +IN A | A video + input signal |
| 14 | -IN A | A video - signal input |
| 15 | A OS2 | A black level adjust (OFFSET) |
| 16 | B OS1 | B black level adjust (OFFSET) |
| 17 | +IN B | B video + signal input |
| 18 | -IN B | B video - signal input |
| 19 | B OS2 | B black level adjust (OFFSET) |
| 20 | OUT | multiplier output |

Revision Date: January 1994.

DESCRIPTION

The GT4122 multiplier is a monolithic dual-channel, broadcast quality video mixer.

Featuring two wideband video inputs and a single control input, the GT4122 achieves high quality video mixing of the two video input signals to a single output by implementing the function:

$$V_{OUT} = V_A \cdot V_C + V_B (1 - V_C)$$

where V_C is the control input voltage, which may be varied continuously over the control range and V_A and V_B are the video input signals.

The GT4122 operates with power supply voltages of ±10 volts and typically draws 24 mA of current. The GT4122 is available in a 20 pin DIP and 20 pin SOIC packaging.

An Application Note entitled 'Using the GT4122 and GT4124 Video Mixer ICs' (Gennum Document 520-44) is available from Gennum Corporation.

ORDERING INFORMATION

Part No.	Package Type	Temperature
GT4122 - CDF	20 PDIP	0° to 70°C
GT4122 - CKF	20 SOIC	0° to 70°C

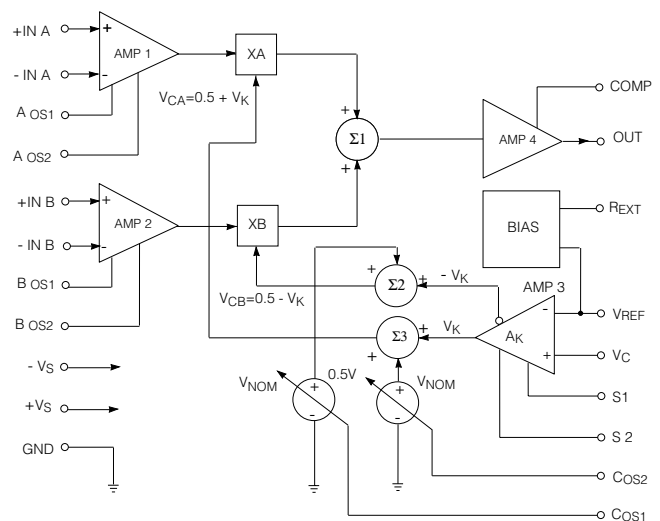

$$\text{Device Function: } V_{OUT} = V_{INA} \cdot [V_{NOM} + A_K (V_C - V_{REF})] + V_{INB} \cdot [V_{NOM} - A_K (V_C - V_{REF})]$$

FUNCTIONAL BLOCK DIAGRAM

Document No. 520 - 25 - 4

ABSOLUTE MAXIMUM RATINGS

PARAMETER	VALUE
Supply Voltage (V_S)	± 13.5 V
Operating Temperature Range	$0^\circ \text{C} \leq T_A \leq 70^\circ \text{C}$
Storage Temperature Range	$-65^\circ \text{C} \leq T_S \leq 150^\circ \text{C}$
Lead Temperature (Soldering, 10 Sec)	260°C
Video Input Voltage (V_A, V_B) to ground	± 5 V
Control Input Voltage (V_C) to ground	± 5 V
Video Input Differential Voltage ($V_A - V_B$)	± 5 V
Control Input Differential Voltage ($V_C - V_{REF}$)	± 5 V

ELECTRICAL CHARACTERISTICS ($+V_S = -V_S = 10\text{V}$, $0^\circ\text{C} \leq T_A \leq 70^\circ\text{C}$ unless otherwise shown)

	PARAMETER	SYMBOL	CONDITIONS	MIN	TYP	MAX	UNITS
POWER SUPPLIES	Supply Voltage	$\pm V_S$	Operating Range	± 9	± 10	± 12	volts
	+ Supply Current	I^+	$R_{EXT} = 1 \text{ k}\Omega$	-	24	28	mA
	- Supply Current	I^-	$R_{EXT} = 1 \text{ k}\Omega$	-	18	20	mA
SIGNAL CHANNEL	Bandwidth	BW	at ± 0.1 dB $V_{SIG} = 150 \text{ mVp-p}$	25	30	-	MHz
	Frequency Response		DC - 10 MHz	-	± 0.05	-	dB
	Differential Gain	∂g	$V_{IN} = 40 \text{ IRE at } 3.58 \text{ MHz}$	-	0.01	0.03	%
	Differential Phase	∂p	$V_{IN} = 40 \text{ IRE at } 3.58 \text{ MHz}$	-	0.01	0.03	degrees
	Signal to Noise	S/N	$V_{SIG} = 1 \text{ volt, BW} = 5 \text{ MHz}$	64	70	-	dB
	Gain - open loop	A_{OL}	100 kHz ($\beta = 0\%$)	54	60	66	dB
	Gain - closed loop	A_{CL}	100 kHz ($\beta = 100\%$)	-0.01	-0.005	-	dB
	Delay	$t_{d \text{ SIG}}$		-	-	10	ns
	Off Isolation & Crosstalk	$V_A \text{ or } B/V_O$	$f_{SIG} = 5 \text{ MHz (see note 1)}$	80	85	-	dB
$V_C/V_A \text{ or } B$		$f_{SIG} = 5 \text{ MHz (see note 2)}$	90	95	-	dB	
CONTROL CHANNEL	Bandwidth	BW	at ± 0.1 dB $V_{SIG} = 150 \text{ mVp-p}$	25	30	-	MHz
	Delay	$t_{d \text{ CONT}}$		-	-	10	ns
	Linearity			-	1	-	%
	Control Breakthrough		$V_{CONT} = 0-1 \text{ V } f = 1-10 \text{ MHz}$	-	-55	-50	dB
	Crossfade Balance		$V_{CONT} = 0-1 \text{ V } f = 3.58 \text{ MHz}$	-	3	5	mVpp
	Control Range	V_{CONT}		0	-	+5	V

NOTE: 1 $V_A \text{ or } B = 1 \text{ Vp-p}$ output taken from OUTPUT

2 $V_{CONT} = 1 \text{ Vp-p}$ output taken from $V_A \text{ or } V_B$

DETAILED DESCRIPTION

The GT4122 is a broadcast quality monolithic integrated circuit specifically designed to linearly mix two video signals under the control of a third signal.

Referring to the block diagram, the input signals are applied to conventional differential amplifiers (AMP1 and AMP2). Each amplifier has provisions for individually adjusting the DC offset (OFFSET).

Following each input amplifier, the signals are applied to linear multiplier circuits (XA and XB) whose outputs are the product of the incoming signals and controlling voltages (V_{CA}) or (V_{CB}). The controlling voltage V_{CA} is the sum of a nominal 0.5V source (V_{NOM}) and a variable source V_K while V_{CB} is made up of the sum of the nominal voltage V_{NOM} and $-V_K$.

V_K and $-V_K$ are themselves proportional to the difference between an externally applied reference voltage (V_{REF}) and an externally applied CONTROL voltage (V_C). The voltages V_K and $-V_K$ are produced by a differential amplifier (AMP3) whose gain is A_K . This gain can be altered by two external resistors, R_{EXT} and R_{SPAN} according to the following formula:

$$A_K \approx \frac{0.85 \cdot R_{EXT}}{R_{SPAN}} \quad [1k\Omega < R_{EXT} < 3k\Omega]$$

Note that R_{EXT} is connected between the R_{EXT} pin and ground and R_{SPAN} is connected between the pins S1 and S2.

Each of the voltages ($+V_K$ and $-V_K$) is applied to summing circuits ($\Sigma 2$ and $\Sigma 3$) whose second inputs are DC voltage sources that can also be slightly varied. The nominal value of these voltage sources is 0.5 volts.

When they are exactly 0.5V and when $V_C = V_{REF}$, the gain of each signal channel of the mixer is 0.5 (50%).

By connecting the ends of an external potentiometer (CONTROL OFFSET) between the offset pins COS1 and COS2, the voltage sources can be altered differentially. If a second potentiometer (50% GAIN) is connected between the wiper of the CONTROL OFFSET potentiometer and the supply voltage, the voltage sources can be varied in a common mode fashion. In this way not only can the control range of the mixer be varied but also the point at which 50% of each input signal appears at the output.

The outputs from the multiplier circuits (XA and XB) are then applied to a summing circuit ($\Sigma 1$) whose output feeds a wideband amplifier (AMP4) and presents the mixed signals to the outside world.

Although there are two separate differential inputs, the usual operational amplifier gain-setting methods can be applied to determine the closed loop gain of the mixer. Usually the mixer will be configured for unity gain by connecting both inverting inputs ($-IN A$, $-IN B$) to the common output (OUT). In this case, the general transfer function is:

$$V_O = V_A \cdot [V_{NOM} + A_K \cdot (V_C - V_{REF})] + V_B \cdot [V_{NOM} - A_K \cdot (V_C - V_{REF})]$$

(Unity gain configuration)

Where V_A and V_B are the input analog signals applied to $+IN A$ and $+IN B$ respectively, and V_C is the CONTROL voltage.

Note that V_{NOM} ranges between $0.45V < V_{NOM} < 0.55$.

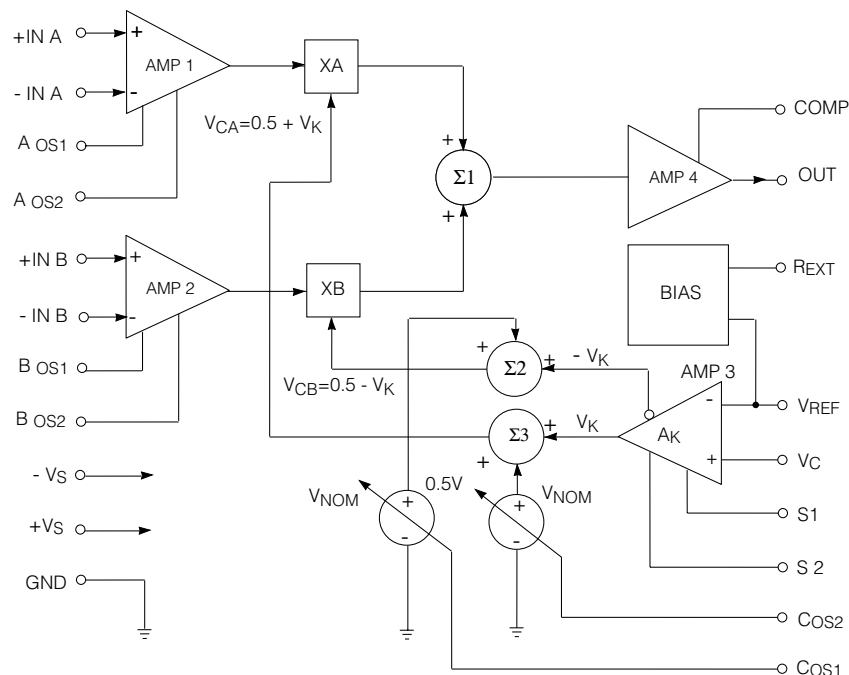

Device Function: $V_{OUT} = V_{INA} \cdot [V_{NOM} + A_K (V_C - V_{REF})] + V_{INB} \cdot [V_{NOM} - A_K (V_C - V_{REF})]$

FUNCTIONAL BLOCK DIAGRAM

For normal video mixer operation, the control range (SPAN) is usually 0 to 1V and will occur when $A_K=1$, $V_{REF}=0.5V$ and $V_{NOM}=0.5$ volts. A change in V_C from 0 to 1V will then produce an effect such that the output signal contains 100% of Channel B when V_C is 0V and 100% of Channel A when V_C is 1 volt. For the above conditions, the general unity gain transfer function reduces to:

$$V_O = V_A \cdot V_C + V_B \cdot (1 - V_C)$$

Since the operation of the mixer is limited to two quadrants, no signal inversions occur if the control voltage exceeds the range zero to one volt in either direction. The topology is designed so that once the control voltage reaches either end of its range, the channel which is ON remains fully ON and the OFF channel remains fully OFF.

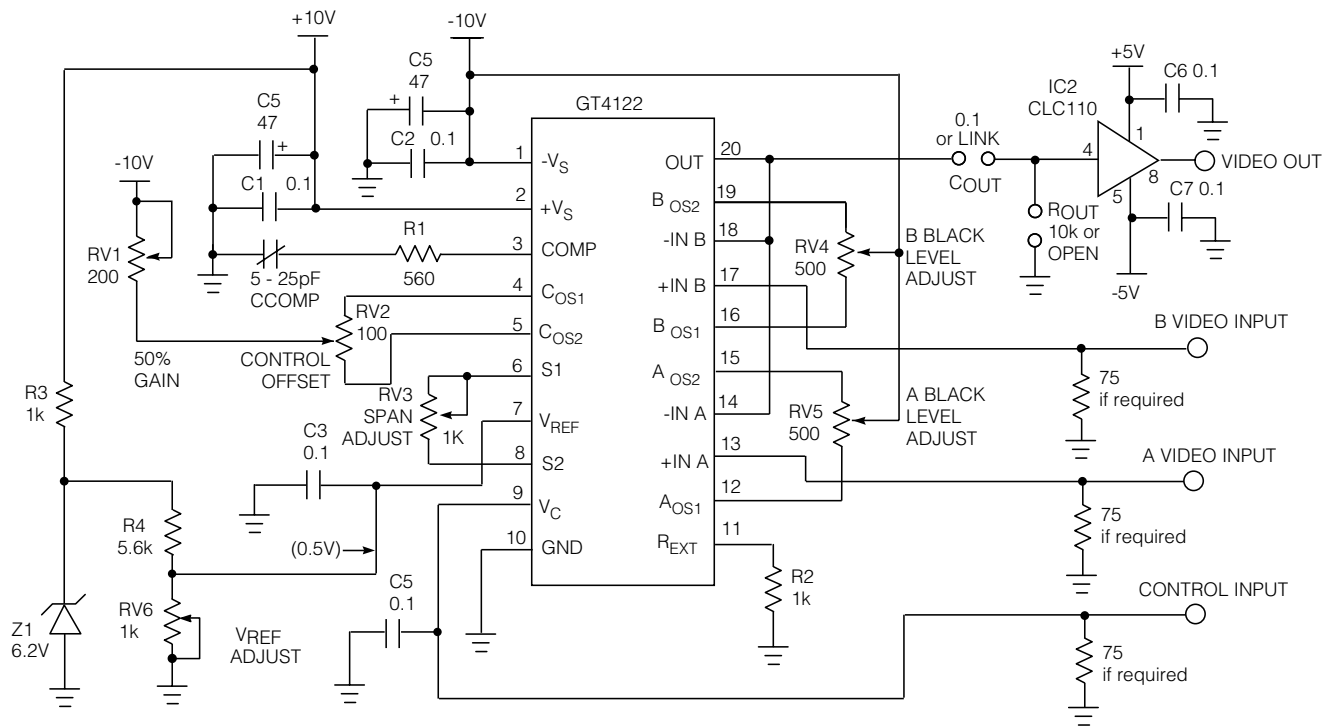

NOTE: C5 is used when the CONTROL VOLTAGE (V_C) is derived from a power supply.
All resistors in ohms, all capacitors in μF unless otherwise stated.

Fig. 1 Test Circuit

TYPICAL PERFORMANCE CURVES FOR GT4122

(Unless otherwise shown, $V_S = \pm 10\text{ V}$, $R_L = 10\text{ k}\Omega$)

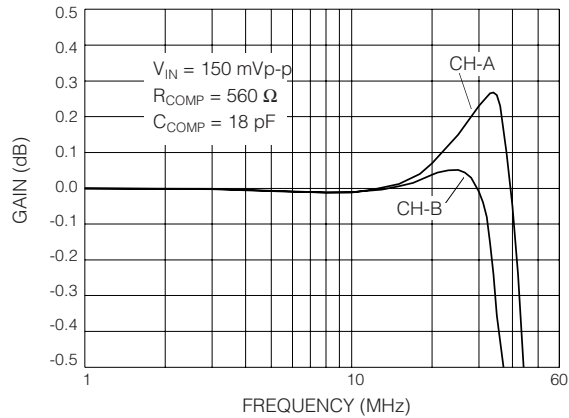

Fig. 2 Frequency Response

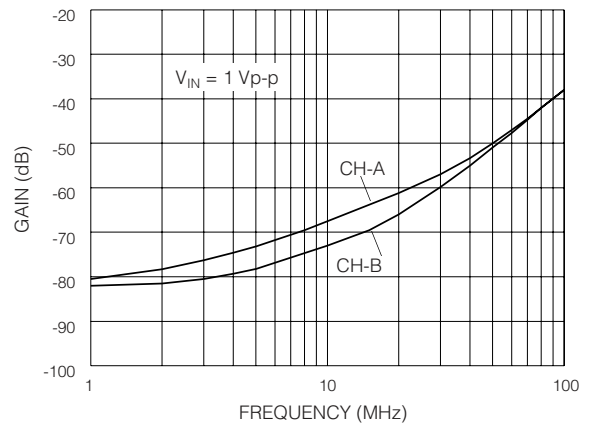

Fig. 3 Crosstalk vs Frequency

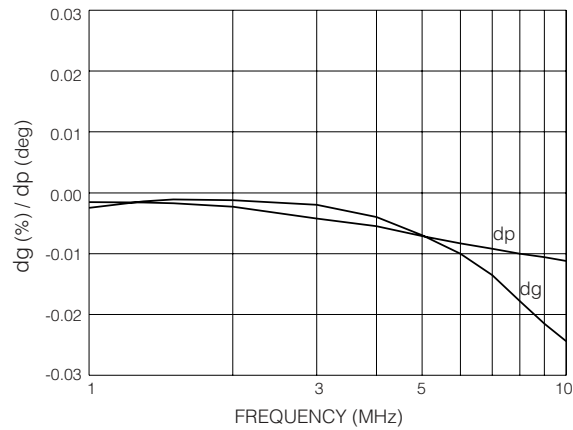

Fig. 4 Differential Gain & Phase vs Frequency

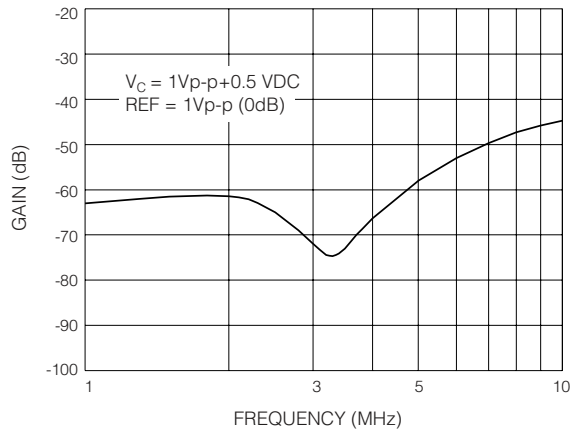

Fig. 5 Crossfade Balance vs Frequency

CAUTION
ELECTROSTATIC
SENSITIVE DEVICES
DO NOT OPEN PACKAGES OR HANDLE
EXCEPT AT A STATIC-FREE WORKSTATION



DOCUMENT IDENTIFICATION

PRODUCT PROPOSAL

This data has been compiled for market investigation purposes only, and does not constitute an offer for sale.

ADVANCE INFORMATION NOTE

This product is in development phase and specifications are subject to change without notice. Gennum reserves the right to remove the product at any time. Listing the product does not constitute an offer for sale.

PRELIMINARY DATA SHEET

The product is in a preproduction phase and specifications are subject to change without notice.

DATA SHEET

The product is in production. Gennum reserves the right to make changes at any time to improve reliability, function or design, in order to provide the best product possible.