

PART NUMBER CODING

C D N - S268

MATERIALS (INSULATOR/CONTACT)

E = BLUE PBT & PHOSPHOR BRONZE
 OPERATING TEMP: -65°C TO +125°C
 PROCESSING TEMP: WAVE/MANUAL SOLDERING

R = BROWN PPS & PHOSPHOR BRONZE
 OPERATING TEMP: -65°C TO +125°C
 PROCESSING TEMP: 260°C MAX FOR 20 SEC

G = BLACK PA9T & PHOSPHOR BRONZE
 OPERATING TEMP: -65°C TO +125°C
 PROCESSING TEMP: 260°C MAX FOR 20 SEC

H = BLUE PBT & BERYLLIUM COPPER
 OPERATING TEMP: -65°C TO +125°C
 PROCESSING TEMP: WAVE/MANUAL SOLDERING

A = BROWN PPS & BERYLLIUM COPPER
 OPERATING TEMP: -65°C TO +150°C
 PROCESSING TEMP: 260°C MAX FOR 20 SEC

J = BLACK PA9T & BERYLLIUM COPPER
 OPERATING TEMP: -65°C TO +150°C
 PROCESSING TEMP: 260°C MAX FOR 20 SEC

F = BROWN PPS & SPINODAL (CONSULT FACTORY)
 OPERATING TEMP: -65°C TO +200°C
 (CONSULT FACTORY FOR SPECIAL SOLDERING REQUIREMENTS)
 AVAILABLE IN OVERALL GOLD ONLY (S OR M PLATING CODE)

W = NATURAL BROWN PEEK & BERYLLIUM NICKEL (CONSULT FACTORY)
 OPERATING TEMP: -65°C TO +250°C
 PROCESSING TEMP: 260°C MAX FOR 20 SEC
 AVAILABLE IN OVERALL GOLD ONLY (M PLATING CODE)

TERMINATION TYPE
 RX = .185 [4.70] TAIL LENGTH
 RJ = .165 [4.19] TAIL LENGTH

NUMBER OF POSITIONS
 (CONTACTS PER ROW)

PLATING

ALL PLATINGS ARE LEAD FREE AND HAVE .000050" MIN NICKEL UNDERPLATE

CONTACT SURFACE	TERMINATION
B = .000010" GOLD	.000100" PURE TIN, MATTE
C = .000030" GOLD	.000100" PURE TIN, MATTE
G = .000010" GOLD	.000005" GOLD
Y = .000030" GOLD	.000005" GOLD
S = .000010" GOLD	.000010" GOLD OVERALL
M = .000030" GOLD	.000010" GOLD OVERALL
**E = .000100" PURE TIN, MATTE	.000100" PURE TIN, MATTE, OVERALL

**OVERALL TIN ONLY AVAILABLE ON MATERIAL CODES E, R, G ONLY

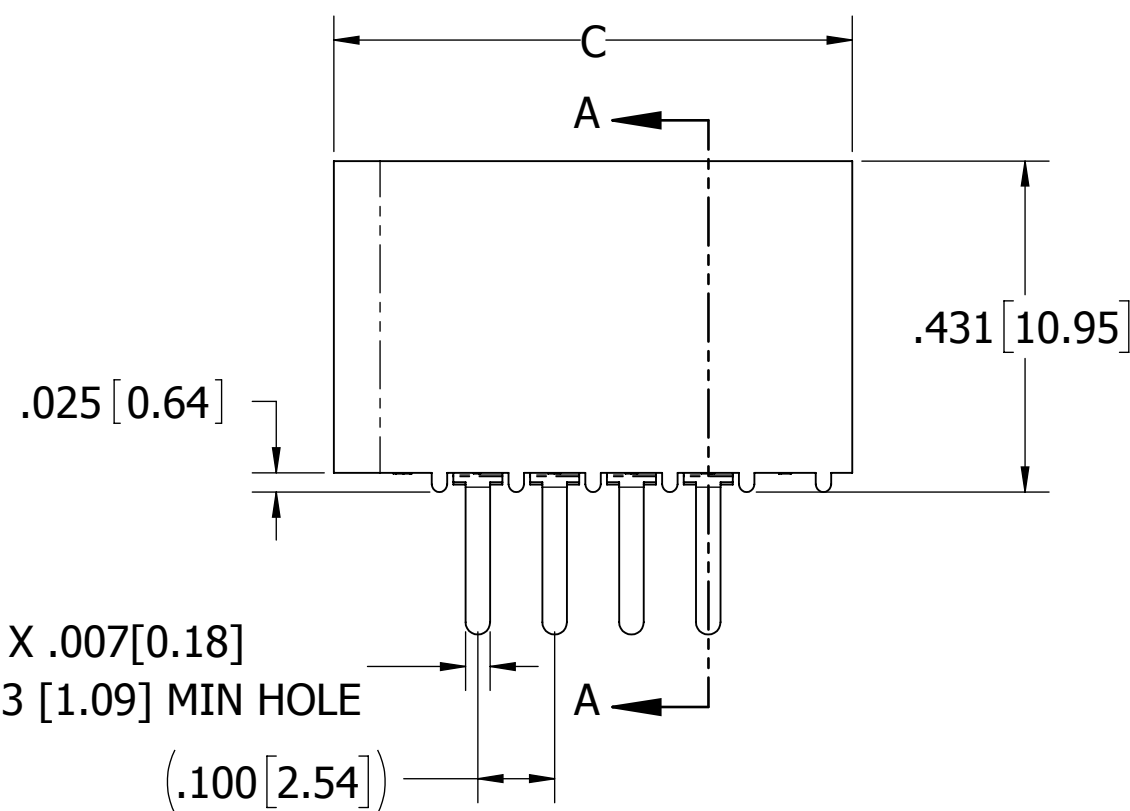
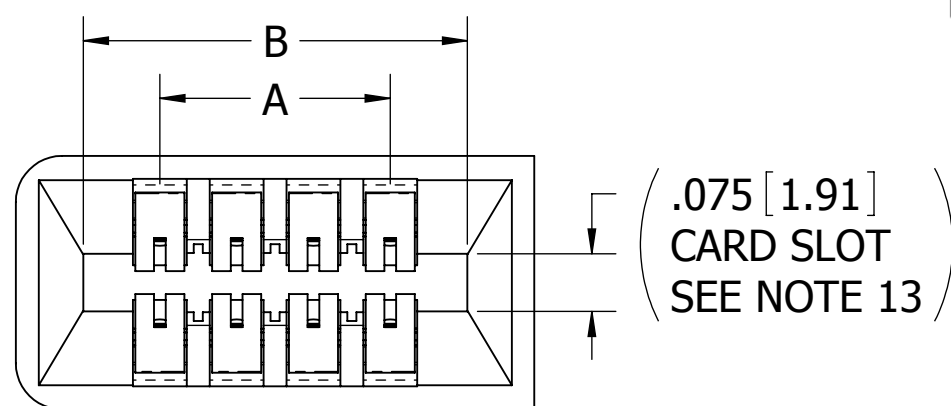

REVISIONS				
REV.	ECO. NO	DESCRIPTION	DATE	BY
A	2786	INITIAL RELEASE	6/14/2013	JH
B	2928	TABULATE POSITION OPTION	2/7/2014	JH
C	3213	UPDATE DWG FORMAT, UPDATE TOP VIEW TO ADD POLARIZING KEY SLOTS AND BOTTOM VIEW TO ADD SIX STANDOFFS	5/6/2015	MG
D	3615	ADD POS 2, 9 & 23 TO DIM TABLE, ADD 'G', 'J', 'F' & 'W' MATERIAL, UPDATE PART NUMBER CODING AND TITLE BLOCK.	12/29/2015	MG/EP

PART NUMBER	NO. OF POS.	A±.008[0.20]		B±.008[0.20]		C±.015[0.38]		F+.005[0.13]/-.015[0.38]	
		IN	MM	IN	MM	IN	MM	IN	MM
__C02D__N-S268	2	0.100	2.54	0.300	7.62	0.475	12.07	0.330	8.38
__C03D__N-S268	3	0.200	5.08	0.400	10.16	0.575	14.61		
__C04D__N-S268	4	0.300	7.62	0.500	12.70	0.675	17.15		
__C07D__N-S268	7	0.600	15.24	0.800	20.32	0.975	24.77		
__C09D__N-S268	9	0.800	20.32	1.000	25.40	1.175	29.85		
__C23D__N-S268	23	2.200	55.88	2.400	60.96	2.575	65.41		
__C24D__N-S268	24	2.300	58.42	2.500	63.50	2.675	67.95		

CONTACT IDs:
 B 1 2 3 ...
 A 1 2 3 ...

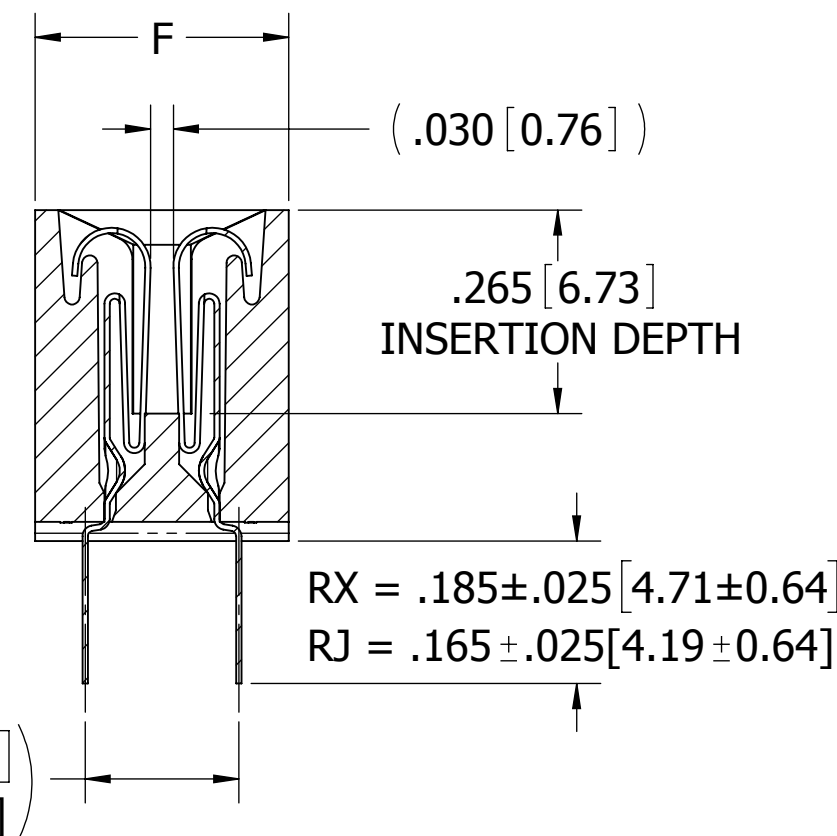
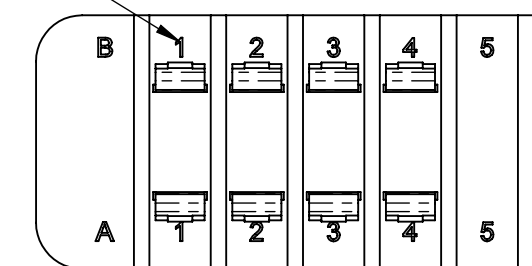

SECTION A-A

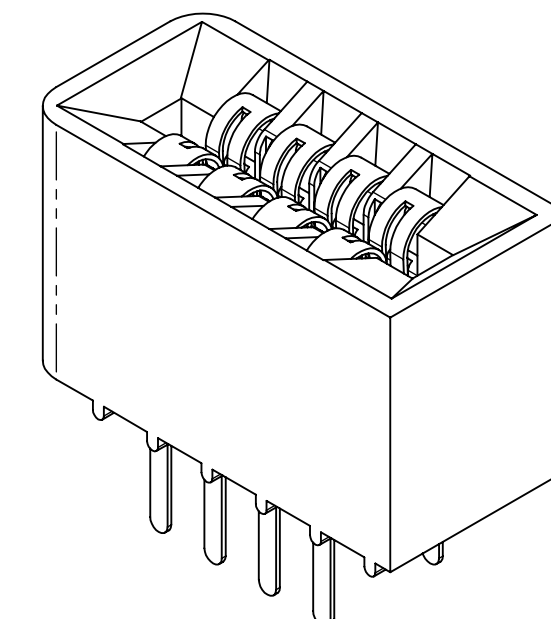

NOTES:

- INSULATOR MATERIAL: SEE PART NUMBER CODING
- CONTACT MATERIAL: SEE PART NUMBER CODING
- PLATING: SEE PART NUMBER CODING
- OPERATING TEMPERATURE: SEE PART NUMBER CODING
- PROCESSING TEMP: SEE PART NUMBER CODING
- UL FLAMMABILITY RATING: 94V-0
- OPERATING VOLTAGE: 700 VAC
- CURRENT RATING: 3 AMP
- CONTACT RESISTANCE: 30 MILLI OHMS MAX
- INSULATION RESISTANCE: 5000 MEGA OHMS
- DURABILITY: 500 CYCLES MINIMUM
- CONNECTOR IDENTIFICATION: THE PART SHALL BE MARKED WITH A PART NUMBER AND LOT CODE
- BOARD THICKNESS ACCOMMODATED: .062 ± .008 [1.57 ± 0.20]
- INSERTION FORCE: 16 OZ MAX PER CONTACT PAIR WHEN USING A .062 [1.57] TEST BLADE
- INTERNAL INSPECTION TO BE PER SULLIN'S WORK INSTRUCTION WI7.3-01
- WITHDRAWAL FORCE: 1 OZ MIN PER CONTACT PAIR USING .062 [1.57] TEST BLADE
- MODIFICATION: NO EARS, STANDARD RADIUS ONE END, SQUARE CORNER OTHER END



CUSTOMER COPY

UNLESS OTHERWISE SPECIFIED: DIMENSIONS ARE IN INCHES [MM]		DRAWN	DATE	NAME					
			6/14/13	JH					
TOLERANCES:					THE INFORMATION HEREIN CONTAINS PROPRIETARY INFORMATION OF SULLINS ELECTRONICS AND IS NOT TO BE REPRODUCED, USED OR DISCLOSED TO OTHERS FOR ANY PURPOSE EXCEPT AS SPECIFICALLY AUTHORIZED IN WRITING BY AN OFFICER OF SULLINS ELECTRONICS.				
ANGULAR: ± 1°					TITLE EDGE CARD, .100 CC, LP				
DECIMALS .XX = ± .02 [.5] .XXX = ± .005 [.13] .XXXX = ± .0005 [.013]					PART NUMBER __C__D(RX,RJ)N-S268				
SCALE: 4:1		SIZE	CAGE CODE	DWG. NO.	REV				
		C	54453	C12229	D				
					SHEET 1 OF 1				