

MATERIAL NUMBER	ENG. NO.	MATERIAL NUMBER TAPE MOUNTED	ENG. NO.	STUD SIZE	"S" ±.005	"W" MAX	"C" MIN	"L" MAX
190730179	C-830-10	190730180	C-830-10T	10	.198 (5.03)	.540 (13.72)	.393 (9.98)	1.258 (31.95)
190730188	C-830-14	190730190	C-830-14T	14	.265 (6.73)			
190730200	C-830-56	190730201	C-830-56T	56	.328 (8.33)			
190730212	C-836-04	190730213	C-836-04T	04	.119 (3.02)	.292 (7.42)	.306 (7.77)	1.047 (26.59)
190730216	C-836-06	190730218	C-836-06T	06	.146 (3.71)			
190730222	C-836-08	190730224	C-836-08T	08	.173 (4.39)			
190730227	C-840-10	190730228	C-840-10T	10	.198 (5.03)	.602 (15.29)	.466 (11.83)	1.362 (34.59)
190730231	C-840-14	190730232	C-840-14T	14	.265 (6.73)			
190730236	C-840-38	190730237	C-840-38T	38	.390 (9.91)			
190730242	C-840-56	190730243	C-840-56T	56	.328 (8.33)			

DIAGRAM FOR C-830-XX & C-840-XX PARTS

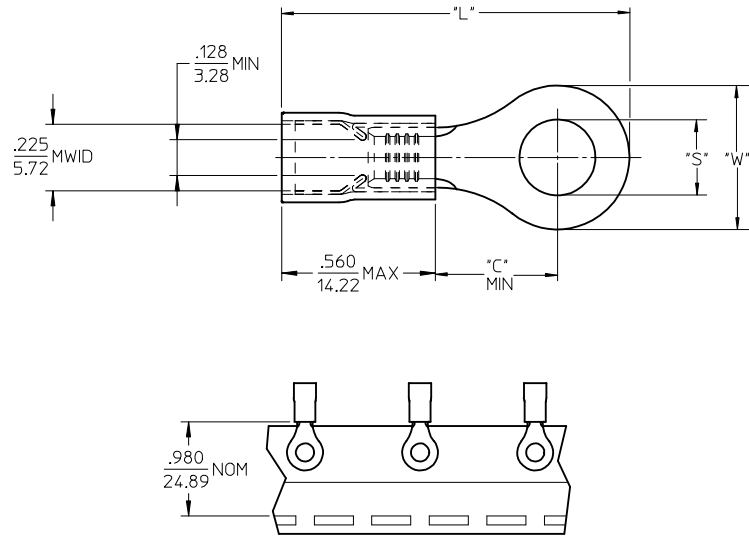
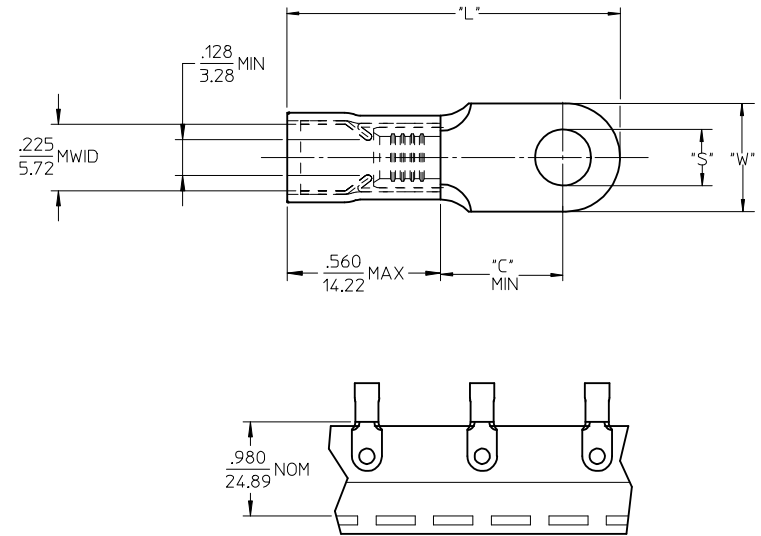

DIAGRAM FOR C-836-XX



SALES DRAWING

NOTES:

- MATERIAL: COPPER (.040/1.02) THICK.
PLATING: ELECTROPLATE TIN
- FERRULE: TIN PLATED BRASS
- INSULATION: YELLOW NYLON
- MWID=MAXIMUM WIRE INSULATION DIA.
- ALL DIMENSIONS IN INCHES (MM).
- WIRE SIZE: 12-10 AWG
4.0-6.0 MM²
- PARTS ARE ROHS COMPLIANT.

ADD 2ND DIAGRAM EC NO: IPG2016-0998 DRAWING: JASO1 2016/01/14 CHKD: JMACNEIL 2016/01/14 APPR: JMACNEIL 2016/01/20	QUALITY SYMBOLS ▽=0 ▽=0	GENERAL TOLERANCES (UNLESS SPECIFIED)		DIMENSION STYLE IN/MM		SCALE	DESIGN UNITS INCH	THIRD ANGLE PROJECTION	
		4 PLACES ± --- ± ---	3 PLACES ± --- ± .005	2 PLACES ± 0.13 ± .01	1 PLACE ± 0.25 ± ---	0 PLACE ± ±	ANGULAR ± 1 °	DRAFT WHERE APPLICABLE MUST REMAIN WITHIN DIMENSIONS	DRAWN BY DMYRICK
REV A2	DESCRIPTION	MATERIAL NO. ENTER PART		APPROVED BY RDEROSS		DATE 03/12/15	DOCUMENT NO. SD-19073-008	SHEET NO. 1 OF 00	
THIS DRAWING CONTAINS INFORMATION THAT IS PROPRIETARY TO MOLEX INCORPORATED AND SHOULD NOT BE USED WITHOUT WRITTEN PERMISSION									