

# 0.30MM CENTER FFC JUMPER CABLE CHART

"A" DIM.	2 ± .08 INCHES 51 ± 2 MM	4 ± .16 INCHES 102 ± 4 MM	6 ± .16 INCHES 152 ± 4 MM	8 ± .20 INCHES 203 ± 5 MM	10 ± .20 INCHES 254 ± 5 MM	12 ± .20 INCHES 305 ± 5 MM
CKTS: 7	150310207	150310407	150310607	150310807	150311007	150311207
CKTS: 9	150310209	150310409	150310609	150310809	150311009	150311209
CKTS: 11	150310211	150310411	150310611	150310811	150311011	150311211
CKTS: 15	150310215	150310415	150310615	150310815	150311015	150311215
CKTS: 21	150310221	150310421	150310621	150310821	150311021	150311221
CKTS: 25	150310225	150310425	150310625	150310825	150311025	150311225
CKTS: 31	150310231	150310431	150310631	150310831	150311031	150311231
CKTS: 33	150310233	150310433	150310633	150310833	150311033	150311233
CKTS: 35	150310235	150310435	150310635	150310835	150311035	150311235
CKTS: 37	150310237	150310437	150310637	150310837	150311037	150311237
CKTS: 39	150310239	150310439	150310639	150310839	150311039	150311239
CKTS: 41	150310241	150310441	150310641	150310841	150311041	150311241
CKTS: 51	150310251	150310451	150310651	150310851	150311051	150311251
CKTS: 61	150310261	150310461	150310661	150310861	150311061	150311261

### NOTES:

- SUBSTRATE AND COVERLAY MATERIAL IS .001" [25um] POLYIMIDE.
- CONDUCTOR IS 1/2 OZ (.0007") [18um] COPPER.
- PLATING IS 2 MICRO INCHES MINIMUM OF HARD GOLD OVER 100 MICRO INCHES MINIMUM OF NICKEL.
- TAIL ENDS ARE .008±.001 [0.20±0.03] THICK.
- JUMPER CABLES ARE SUITABLE FOR USE WITH MOLEX 504754 SERIES CONNECTOR.

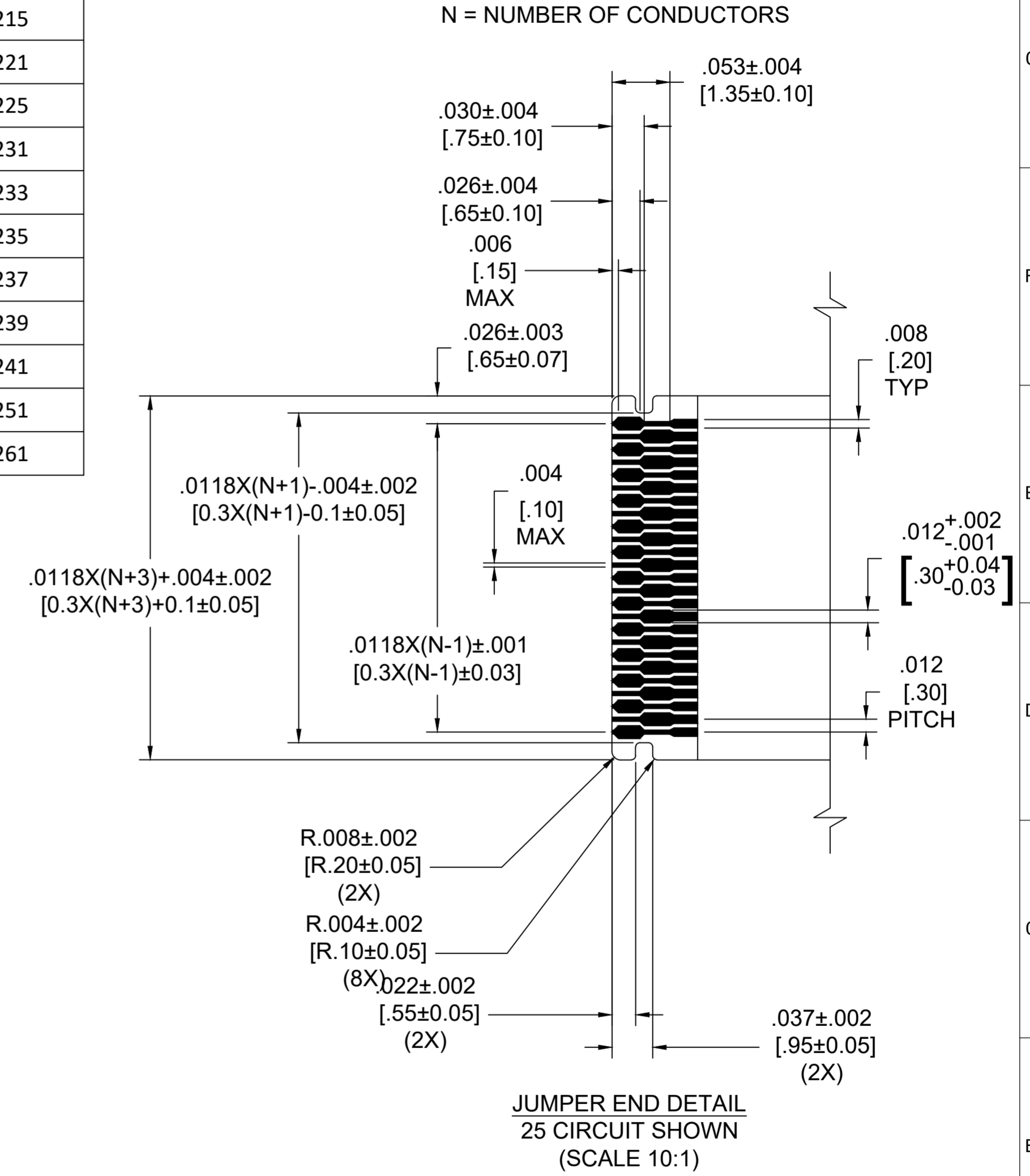
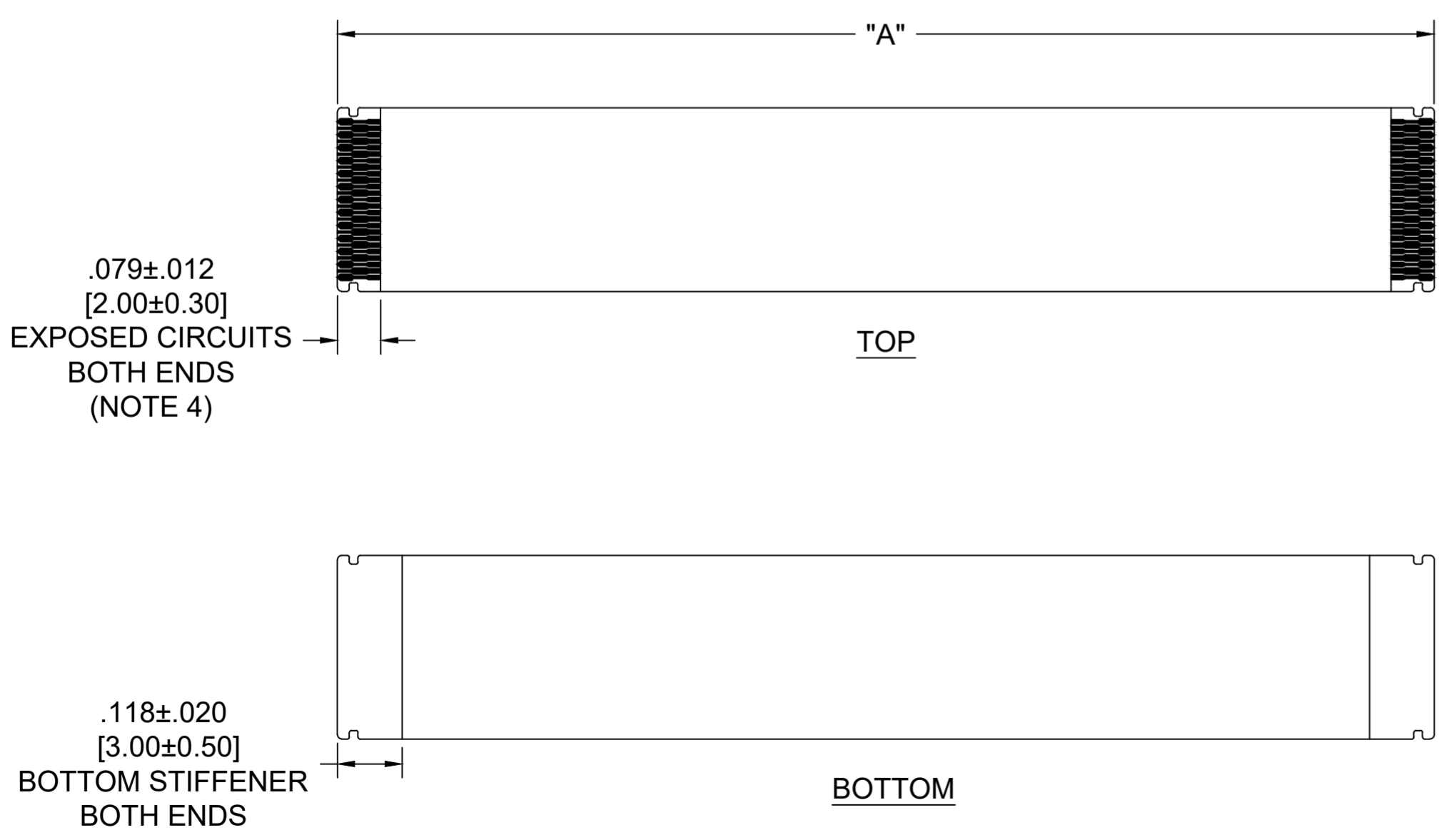

THIS DRAWING CONTAINS INFORMATION THAT IS PROPRIETARY TO MOLEX ELECTRONIC TECHNOLOGIES, LLC AND SHOULD NOT BE USED WITHOUT WRITTEN PERMISSION											
FUNCTIONAL SYMBOLS	DIMENSION UNITS		SCALE		CURRENT REV DESC: PRODUCTION RELEASE						
	MM/INCH		4:1		<p><b>molex</b></p> <p>.3MM PITCH JUMPER CABLES</p>						
	GENERAL TOLERANCES (UNLESS SPECIFIED)										
DIVISIONAL SYMBOLS	mm		INCH		EC NO: 701160		2022/03/28		<p>PRODUCT CUSTOMER DRAWING</p> <p>DOCUMENT NUMBER: 150310001</p> <p>DOC TYPE: PSD</p> <p>DOC PART: 000</p> <p>REVISION: A</p>		
	4 PLACES ±----		±----		DRWN: MIMIG		2022/03/30				
	3 PLACES ±----		±0.01		CHK'D: JSMITH11		2022/03/30				
	2 PLACES ±----		±0.03		APPR: JSMITH11		2022/03/30				
	1 PLACE ±----		±----		INITIAL REVISION:						
0 PLACES ±----		±----		DRWN: MIMIG		2022/03/28		MATERIAL NUMBER		CUSTOMER	
ANGULAR TOL ± 1.0 °				APPR: JSMITH11		2022/03/30		15031		GENERAL MARKET	
DRAFT WHERE APPLICABLE MUST REMAIN WITHIN DIMENSIONS				THIRD ANGLE PROJECTION		DRAWING		SERIES		SHEET NUMBER	
				C-SIZE		15031		SEE CHART		1 OF 1	