



MCP3909
3-Phase Energy Meter
Reference Design
Using the PIC18F2520

Note the following details of the code protection feature on Microchip devices:

- Microchip products meet the specification contained in their particular Microchip Data Sheet.
- Microchip believes that its family of products is one of the most secure families of its kind on the market today, when used in the intended manner and under normal conditions.
- There are dishonest and possibly illegal methods used to breach the code protection feature. All of these methods, to our knowledge, require using the Microchip products in a manner outside the operating specifications contained in Microchip's Data Sheets. Most likely, the person doing so is engaged in theft of intellectual property.
- Microchip is willing to work with the customer who is concerned about the integrity of their code.
- Neither Microchip nor any other semiconductor manufacturer can guarantee the security of their code. Code protection does not mean that we are guaranteeing the product as "unbreakable."

Code protection is constantly evolving. We at Microchip are committed to continuously improving the code protection features of our products. Attempts to break Microchip's code protection feature may be a violation of the Digital Millennium Copyright Act. If such acts allow unauthorized access to your software or other copyrighted work, you may have a right to sue for relief under that Act.

Information contained in this publication regarding device applications and the like is provided only for your convenience and may be superseded by updates. It is your responsibility to ensure that your application meets with your specifications. MICROCHIP MAKES NO REPRESENTATIONS OR WARRANTIES OF ANY KIND WHETHER EXPRESS OR IMPLIED, WRITTEN OR ORAL, STATUTORY OR OTHERWISE, RELATED TO THE INFORMATION, INCLUDING BUT NOT LIMITED TO ITS CONDITION, QUALITY, PERFORMANCE, MERCHANTABILITY OR FITNESS FOR PURPOSE. Microchip disclaims all liability arising from this information and its use. Use of Microchip devices in life support and/or safety applications is entirely at the buyer's risk, and the buyer agrees to defend, indemnify and hold harmless Microchip from any and all damages, claims, suits, or expenses resulting from such use. No licenses are conveyed, implicitly or otherwise, under any Microchip intellectual property rights.

Trademarks

The Microchip name and logo, the Microchip logo, Accuron, dsPIC, KEELOQ, KEELOQ logo, MPLAB, PIC, PICmicro, PICSTART, rfPIC, SmartShunt and UNI/O are registered trademarks of Microchip Technology Incorporated in the U.S.A. and other countries.

FilterLab, Linear Active Thermistor, MXDEV, MXLAB, SEEVAL, SmartSensor and The Embedded Control Solutions Company are registered trademarks of Microchip Technology Incorporated in the U.S.A.

Analog-for-the-Digital Age, Application Maestro, CodeGuard, dsPICDEM, dsPICDEM.net, dsPICworks, dsSPEAK, ECAN, ECONOMONITOR, FanSense, In-Circuit Serial Programming, ICSP, ICEPIC, Mindi, MiWi, MPASM, MPLAB Certified logo, MPLIB, MPLINK, mTouch, PICkit, PICDEM, PICDEM.net, PICtail, PIC³² logo, PowerCal, PowerInfo, PowerMate, PowerTool, REAL ICE, rfLAB, Select Mode, Total Endurance, WiperLock and ZENA are trademarks of Microchip Technology Incorporated in the U.S.A. and other countries.

SQTP is a service mark of Microchip Technology Incorporated in the U.S.A.

All other trademarks mentioned herein are property of their respective companies.

© 2008, Microchip Technology Incorporated, Printed in the U.S.A., All Rights Reserved.

 Printed on recycled paper.

QUALITY MANAGEMENT SYSTEM
CERTIFIED BY DNV
== ISO/TS 16949:2002 ==

Microchip received ISO/TS-16949:2002 certification for its worldwide headquarters, design and wafer fabrication facilities in Chandler and Tempe, Arizona; Gresham, Oregon and design centers in California and India. The Company's quality system processes and procedures are for its PIC[®] MCUs and dsPIC[®] DSCs, KEELOQ[®] code hopping devices, Serial EEPROMs, microperipherals, nonvolatile memory and analog products. In addition, Microchip's quality system for the design and manufacture of development systems is ISO 9001:2000 certified.

Table of Contents

Preface	1
Introduction.....	1
Document Layout	2
Conventions Used in this Guide	3
Recommended Reading.....	4
The Microchip Web Site	4
Customer Support	4
Document Revision History	5
Chapter 1. Product Overview	
1.1 Introduction	7
1.2 What the MCP3909 3-Phase Energy Meter Reference Design Kit Includes ..	8
1.3 Getting Started	9
Chapter 2. Hardware	
2.1 Input and Analog Front End	11
2.2 Clock Generation Circuit And PLL	12
2.3 Meter Output	13
2.4 Power Supply Circuit	14
Chapter 3. PIC18F2520 Calculation and Register Description	
3.1 Register Overview	15
3.2 Signal Flow Summary	16
3.3 Complete Register List	17
3.4 Configuration And Output Registers	21
3.5 Calibration Registers	32
Chapter 4. Meter Protocol and Timings	
4.1 PIC18F2520 Protocol	37
Chapter 5. Meter Calibration	
5.1 Calibration Overview	39
5.2 Active Power Signal Flow and Calibration	41
5.3 RMS Current, RMS Voltage, Apparent Power Signal Flow and Calibration .	42

MCP3909 3-Phase Energy Meter Reference Design

Chapter 6. 3-Phase Energy Meter Calibration Software

6.1 Overview	55
6.2 Using the Calibration Software with the USB Interface Module	55
6.3 Software Overview And Tab Control	56
6.4 Results Frame	57
6.5 Calibration Icons	59
6.6 Register List	59
6.7 Writing to Individual Registers	59
6.8 Meter Calibration	60
6.9 Meter Design Frame	64
6.10 Message Log Frame	65
6.11 Communications Log Frame	66

Appendix A. Schematic and Layouts

A.1 Introduction	67
A.2 Schematics and PCB Layout	67
A.3 Main Board Schematic - Page 1	68
A.4 Main Board Schematic - Page 2	69
A.5 Main Board Schematic - Page 3	70
A.6 Main Board Schematic - Page 4	71
A.7 Main Board Schematic - Page 5	72
A.8 Main Board - Top Layer And Silk-Screen	73
A.9 Main Board - Bottom Layer	74
A.10 USB Interface Module - Schematic	75
A.11 USB Interface Module - Top Silk-Screen Layer	76
A.12 USB Interface Module - Top Traces And Pads Layer	76
A.13 USB Interface Module - Bottom Silk-Screen Layer	77
A.14 USB Interface Module - Bottom Traces And Pads Layer	77

Appendix B. Bill Of Materials (BOM)

Worldwide Sales and Service	84
--	-----------



MCP3909 3-PHASE ENERGY METER REFERENCE DESIGN

Preface

NOTICE TO CUSTOMERS

All documentation becomes dated, and this manual is no exception. Microchip tools and documentation are constantly evolving to meet customer needs, so some actual dialogs and/or tool descriptions may differ from those in this document. Please refer to our web site (www.microchip.com) to obtain the latest documentation available.

Documents are identified with a “DS” number. This number is located on the bottom of each page, in front of the page number. The numbering convention for the DS number is “DSXXXXA”, where “XXXX” is the document number and “A” is the revision level of the document.

For the most up-to-date information on development tools, see the MPLAB® IDE on-line help. Select the Help menu, and then Topics to open a list of available on-line help files.

INTRODUCTION

This chapter contains general information that will be useful to know before using the MCP3909 3-Phase Energy Meter Reference Design. Items discussed in this chapter include:

- Document Layout
- Conventions Used in this Guide
- Recommended Reading
- The Microchip Web Site
- Customer Support
- Document Revision History

MCP3909 3-Phase Energy Meter Reference Design

DOCUMENT LAYOUT

This document describes how to use the MCP3909 3-Phase Energy Meter Reference Design as a development tool to emulate and debug firmware on a target board. The manual layout is as follows:

- **Chapter 1. “Product Overview”** – Important information on using the MCP3909 3-Phase Energy Meter Reference Design including a getting started section that describes wiring the line and load connections.
- **Chapter 2. “Hardware”** – Includes detail on the function blocks of the meter including the analog front end design, phase lock loop circuitry, and power supply design.
- **Chapter 3. “PIC18F2520 Calculation and Register Description”** – This section describes the digital signal flow for all power output quantities such as RMS current, RMS voltage, active power, and apparent power. This section also includes the calibration registers detail.
- **Chapter 4. “Meter Protocol and Timings”** – Here is described the protocol used for accessing the registers includes commands that are used to interface to the meter.
- **Chapter 5. “Meter Calibration”** – This chapter provides detail on how to calibrate the meter. The PC calibration software that is included with the meter automates the steps and calculations described in this chapter.
- **Chapter 6. “3-Phase Energy Meter Calibration Software”** – Here you can find a detailed description of the calibration software provided with this reference design
- **Appendix A. “Schematic and Layouts”** – Shows the schematic and layout diagrams
- **Appendix B. “Bill Of Materials (BOM)”** – Lists the parts used to build the

CONVENTIONS USED IN THIS GUIDE

This manual uses the following documentation conventions:

DOCUMENTATION CONVENTIONS

Description	Represents	Examples
Arial font:		
Italic characters	Referenced books	<i>MPLAB[®] IDE User's Guide</i>
	Emphasized text	...is the <i>only</i> compiler...
Initial caps	A window	the Output window
	A dialog	the Settings dialog
	A menu selection	select Enable Programmer
Quotes	A field name in a window or dialog	"Save project before build"
Underlined, italic text with right angle bracket	A menu path	<u><i>File>Save</i></u>
Bold characters	A dialog button	Click OK
	A tab	Click the Power tab
N'Rnnnn	A number in verilog format, where N is the total number of digits, R is the radix and n is a digit.	4'b0010, 2'hF1
Text in angle brackets < >	A key on the keyboard	Press <Enter>, <F1>
Courier New font:		
Plain Courier New	Sample source code	#define START
	Filenames	autoexec.bat
	File paths	c:\mcc18\h
	Keywords	_asm, _endasm, static
	Command-line options	-Opa+, -Opa-
	Bit values	0, 1
	Constants	0xFF, 'A'
Italic Courier New	A variable argument	<i>file.o</i> , where <i>file</i> can be any valid filename
Square brackets []	Optional arguments	mcc18 [options] <i>file</i> [options]
Curly brackets and pipe character: { }	Choice of mutually exclusive arguments; an OR selection	errorlevel {0 1}
Ellipses...	Replaces repeated text	var_name [, var_name...]
	Represents code supplied by user	void main (void) { ... }

MCP3909 3-Phase Energy Meter Reference Design

RECOMMENDED READING

This user's guide describes how to use the MCP3909 3-Phase Energy Meter Reference Design. Other useful documents are listed below. The following Microchip documents are available and recommended as supplemental reference resources.

MCP3909 Data Sheet, “Energy Metering IC with SPI Interface and Active Power Pulse Output” (DS22025)

This data sheet provides detailed information regarding the MCP3909 device.

AN994 Application Note “IEC61036 Meter Design using the MCP3905/6 Energy Metering Devices” (DS00994)

This application note documents the design decisions associated with using the MCP390X devices for energy meter design and IEC compliance.

THE MICROCHIP WEB SITE

Microchip provides online support via our web site at www.microchip.com. This web site is used as a means to make files and information easily available to customers. Accessible by using your favorite Internet browser, the web site contains the following information:

- **Product Support** – Data sheets and errata, application notes and sample programs, design resources, user's guides and hardware support documents, latest software releases and archived software
- **General Technical Support** – Frequently Asked Questions (FAQs), technical support requests, online discussion groups, Microchip consultant program member listing
- **Business of Microchip** – Product selector and ordering guides, latest Microchip press releases, listing of seminars and events, listings of Microchip sales offices, distributors and factory representatives

CUSTOMER SUPPORT

Users of Microchip products can receive assistance through several channels:

- Distributor or Representative
- Local Sales Office
- Field Application Engineer (FAE)
- Technical Support

Customers should contact their distributor, representative or field application engineer (FAE) for support. Local sales offices are also available to help customers. A listing of sales offices and locations is included in the back of this document.

Technical support is available through the web site at: <http://support.microchip.com>

DOCUMENT REVISION HISTORY

Revision B (October 2008)

1. Updated Figure 1-1 photo.
2. Updated Figure 1-3 photo.
3. **Section 2.1 “Input and Analog Front End”**: Added note for revision 2 hardware. Chasnged values of reistors in text and Figure 2-1.
4. **Appendix A. “Schematic and Layouts”**: Updated Schematics and Board Layouts for Revision 2.
5. **Appendix B. “Bill Of Materials (BOM)”**: Updated for Revision 2.

Revision A (February 2007)

- Initial Release of this Document.

MCP3909 3-Phase Energy Meter Reference Design

NOTES:

Chapter 1. Product Overview

1.1 INTRODUCTION

The MCP3909 3-Phase Energy Meter Reference Design is a fully functional 3-phase meter. Please note that the meters are not shipped calibrated and should be calibrated using standard meter calibration equipment and the software included with the kit. There are two boards that comprise the complete meter: the main board and the USB communications module. The communications module shipped with this kit is the PIC18F4550 USB Interface module. The USB Interface module also includes an LCD display. The main board contains the analog circuitry and the PIC18F2520 device that functions as the main RMS engine. The communications module displays the output of the PIC18F2520 and also connects the meter to the PC for calibration using the PIC18F4550 3-Phase Meter Calibration Software. The meter design contains serially accessible registers and is intended to be flexible and upgraded to a variety of PIC[®] micro-based energy meter designs using the firmware presented herein. The “3-Phase Energy Meter USB software” offers a functional and simple means to monitor and control the PIC18F2520 via USB through the PIC18F4550. In addition, the RS-232 interface of the PIC18F2520 can be used to create custom calibration setups. The energy meter software offers an automated step by step calibration process that can be used to quickly calibrate energy meters.

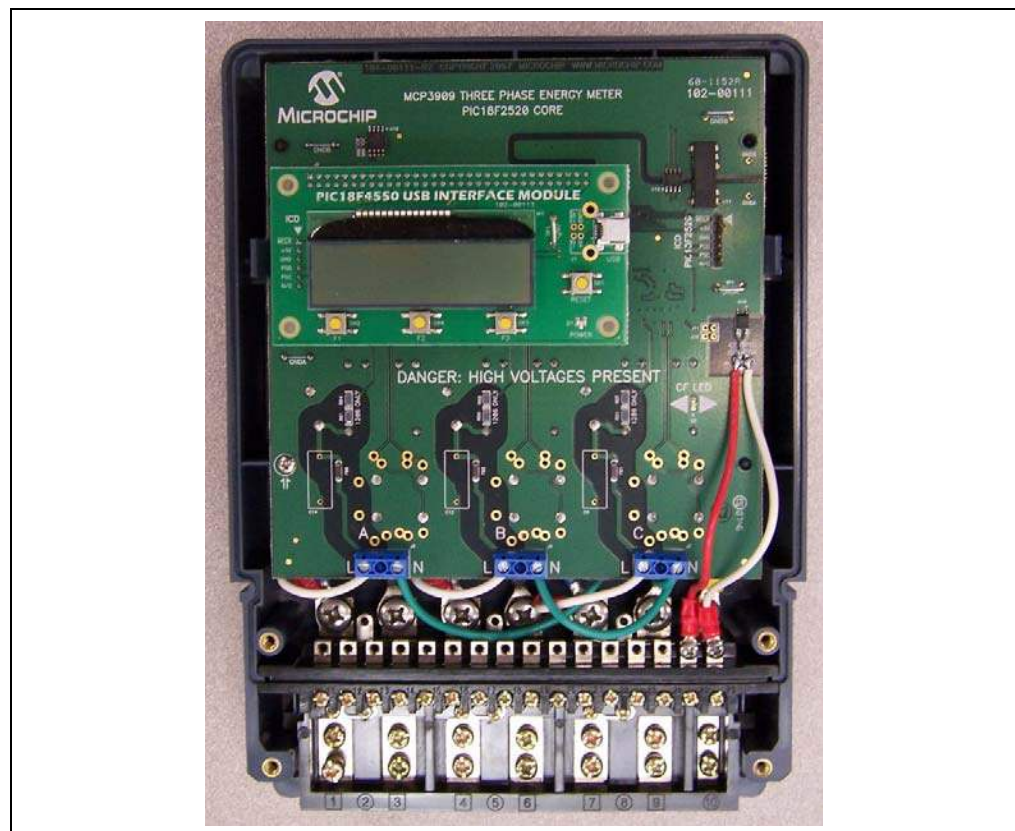

FIGURE 1-1: MCP3909 3-Phase Energy Meter Reference Design.

MCP3909 3-Phase Energy Meter Reference Design

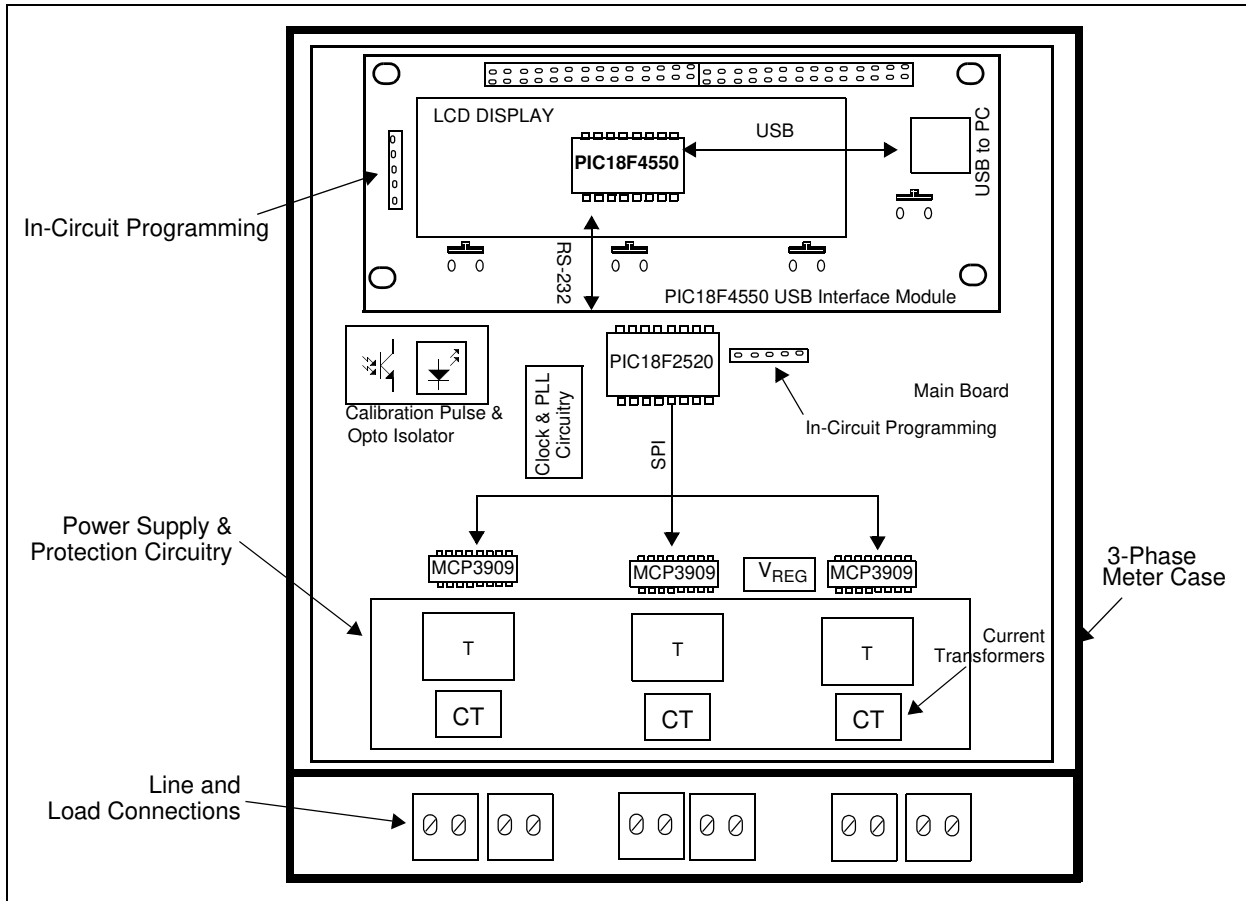

FIGURE 1-2: Functional Block Diagram.

1.2 WHAT THE MCP3909 3-PHASE ENERGY METER REFERENCE DESIGN KIT INCLUDES

This MCP3909 3-Phase Energy Meter Reference Design Kit includes:

- The MCP3909 3-Phase Energy Meter Reference Design (102-00111)
- USB Communications Module (102-00113)
- Analog and Interface Products Demonstration Boards CD-ROM (DS21912)
 - MCP3909 3-Phase Energy Meter Reference Design (DS51643)
 - MCP3909 Data Sheet, "Energy Metering IC with SPI Interface and Active Power Pulse Output" (DS22025)

1.3 GETTING STARTED

To describe how to use the MCP3909 3-Phase Energy Meter Reference Design, the following example is given using both a 4-Wire 3-phase, 220VAC line voltage and connections using an energy meter calibrator equipment or other programmable load source. The meter design uses a 5A load for calibration current and a maximum current (I_{MAX}) of 10A.

All connections described in this section are dependent on the choice of current sensing element and a secondary external transformer may be required in higher current meter designs.

For testing a calibrated meter, the following connections apply for a 4-wire connection.

1.3.1 Step 1: Wiring for 4-Wire Line and Load connections

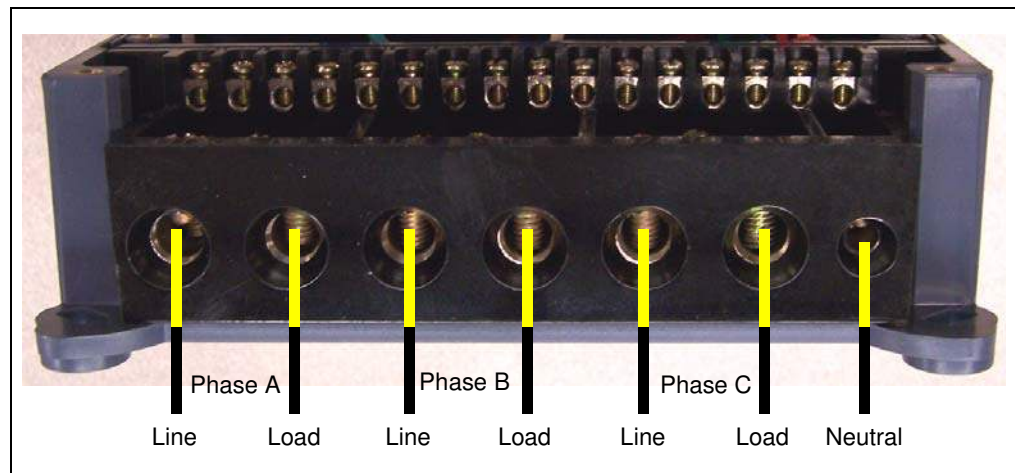

FIGURE 1-3: Example Connections using a 4-Wire System.

1.3.2 Step 2: Turn On Line/Load Power to the Meter (Power the Meter).

The meter will turn on when the line connection has 220V connected to any of the three phases.

1.3.3 Step 3: Connect isolated USB Interface Module.

After connecting the USB cable to a computer running Windows[®] operating system, the meter should be recognized as a HID (Human Interface Device) compliant USB device.

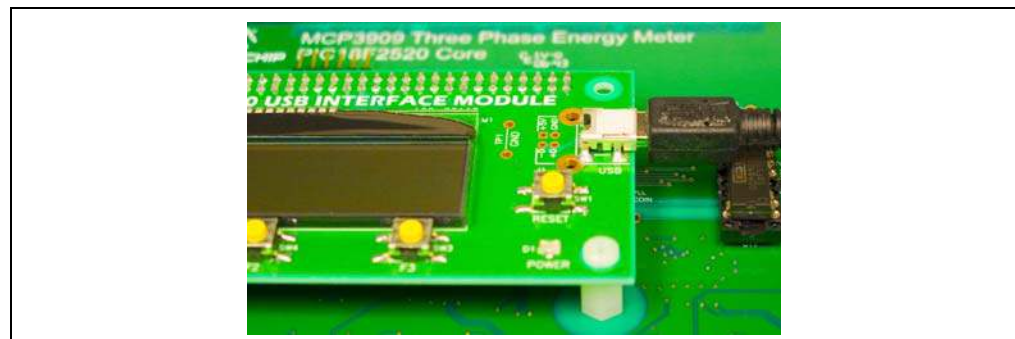

FIGURE 1-4: USB Interface Connections

MCP3909 3-Phase Energy Meter Reference Design

1.3.4 Step 4: Run PC Calibration Software

After the PC has recognized that the energy meter is connected, the calibration software will allow real-time testing and calibration of the meter.

The screenshot displays the MCP3909 3-Phase Energy Meter Software interface. At the top, it indicates 'Meter Present' and features the Microchip logo. The main data table shows the following values:

	PHASE A	PHASE B	PHASE C	TOTAL
Active Power (W)	102.88	0	0	102.88
Apparent Power (KVA)	101.4498	0.0027	0	101.4525
RMS Current (A)	0.45	0.01	0	0.46
RMS Voltage (V)	220.2	0.6	0	220.8

Below the data table is a register list with columns for Address, Name, Bits, R/W, Value (PDR Shown), Description, and Monitor?.

Address	Name	Bits	R/W	Value (PDR Shown)	Description	Monitor?
0x000	MODE1	16	R/W	0x0A	Operating mode	0
0x002	Reserved	16	--	0x00	Reserved (possibly MODE2 register).	0
0x004	STATUS1	16	R	0x00	Status information	0
0x006	Reserved	16	--	0x00	Reserved (possibly STATUS2 register).	0
0x008	CAL_CONTROL	16	R/W	0x00	Calibration control register	0
0x00A	LINE_CYC	16	R/W	0x07	Number of line cycles as a power of two.	0
0x00C	LINE_CYC_CNT	16	R	0x00	Number of line cycles so far.	0
0x00E	Reserved	16	--	0x00	Reserved.	0
0x010	PHA_I_RMS_RAW2	48	R	0x4E1D4058	This is the square of the raw values of phase A current.	0
0x016	PHA_I_RMS_RAW	16	R	0x58E	This is the raw RMS value of phase A current.	0
0x018	PHA_I_RMS	16	R	0x7F	This is the RMS value of phase A current.	0

The interface also includes a 'CALIBRATION' section with radio buttons for A, B, and C, and fields for 'Number of Line Cycles (#)' (128) and 'Expected Calibration Freq. (Hz)' (3.9307). A 'Meter Design' section contains various parameters such as Maximum Current (A), Current Resolution (A), Calibration Voltage (V), Voltage Resolution (V), Power Resolution (W/VA), Calibration Current (A), Calibration Frequency (Hz), and Meter Constant (imp/kWh).

FIGURE 1-5: MCP3909 3-Phase Energy Meter Reference Design Software.

Chapter 2. Hardware

2.1 INPUT AND ANALOG FRONT END

This meter comes populated with components designed for 220V line voltage. At the bottom of the main board are the high voltage line and load connections. The connections to the current transformers for each phase are labelled CTA, CTB and CTC. The three screw terminals to the right of these are the connections to be wired into the line side of the CT for the voltage input and power supply transformer connections. These are labelled PHA, PHB and PHC. The line and neutral connections are labelled “L” and “N”.

Note: Revision 2 of the hardware uses current transformers, P/N: SCT954.

Each phase will use a current transformer and a resistor divider on the voltage channel input. Anti-aliasing low-pass filters will be included on both differential channels. The voltage channel uses 221 kΩ resistors to achieve a divider ratio of 453:1. For a line voltage of 230 V_{RMS}, the channel 1 input signal size will be 718 mV_{PEAK}. The current channel of each phase uses current transformer with a turns ratio of 2000:1 and burden resistance of 56.4 kΩ. The resulting channel 0 signal size is 340 mV_{PEAK} for 20A, or twice the rated maximum current of the meter, still within the input range of the A/D converter of the MCP3909.

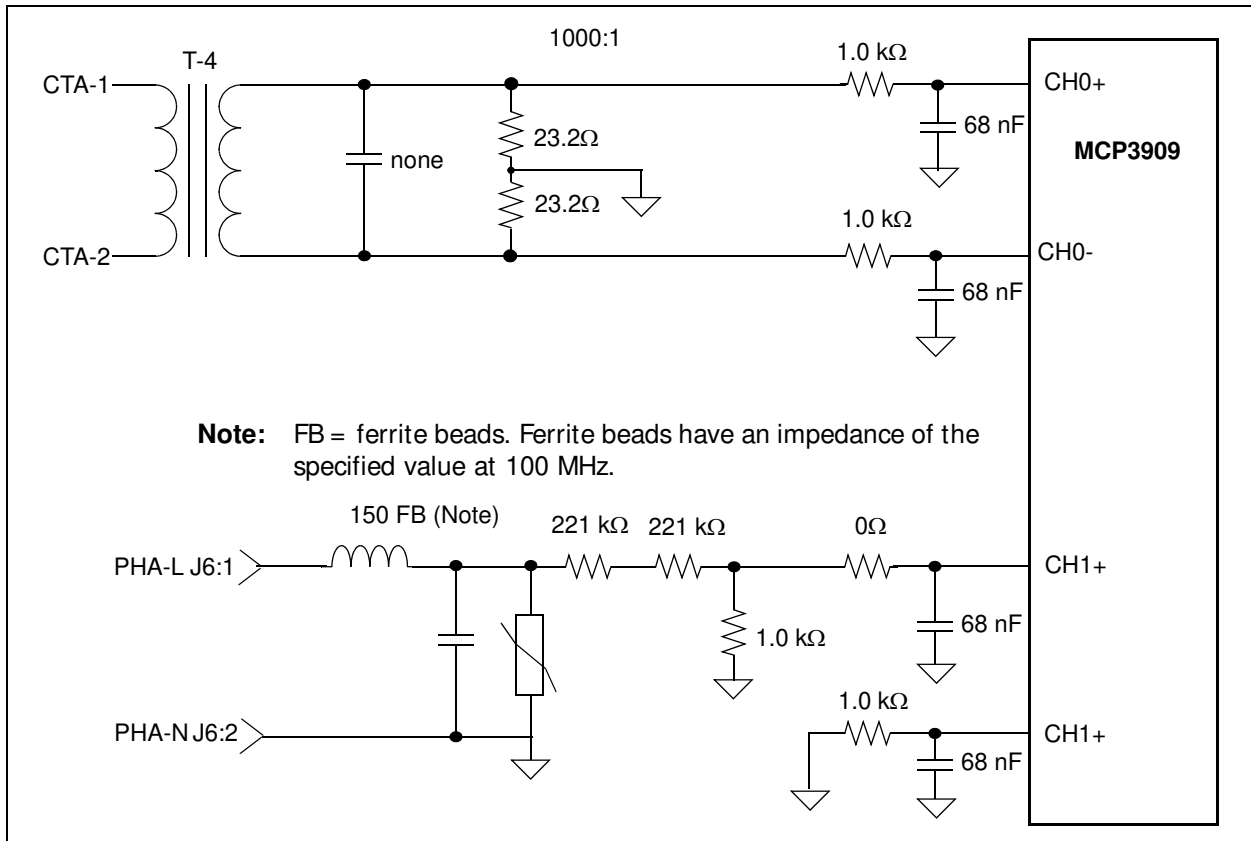

FIGURE 2-1: Analog Front End, Phase A Connections and Reference Designators shown.

MCP3909 3-Phase Energy Meter Reference Design

2.2 CLOCK GENERATION CIRCUIT AND PLL

To achieve simultaneous sampling across the three phases, all 3 MCP3909 devices use the same clock source. In this configuration, the six delta-sigma ADCs are being clocked simultaneously. The source used in this reference design can either be the output of the CCP2 timer on the PIC18F2520 or the output of the phase lock loop (PLL) circuit locked to the line frequency. In either situation, the target number of samples per line cycle is 128. The PLL is designed to have a multiplier of 32768 resulting in a MCLK for the MCP3909 devices that results in exactly 128 samples per line cycle. For lower cost meters, the PLL circuit can be avoided and instead, the CCP2 timer output can provide the appropriate MCLK frequency from a PIC oscillator clock of 39.3216 MHz. This will generate an integer number of samples for either 50 Hz or 60 Hz line frequencies. R31 and R34 select the source of the MCLK signal for the MCP3909s-PLL or CCP2 / 32768..

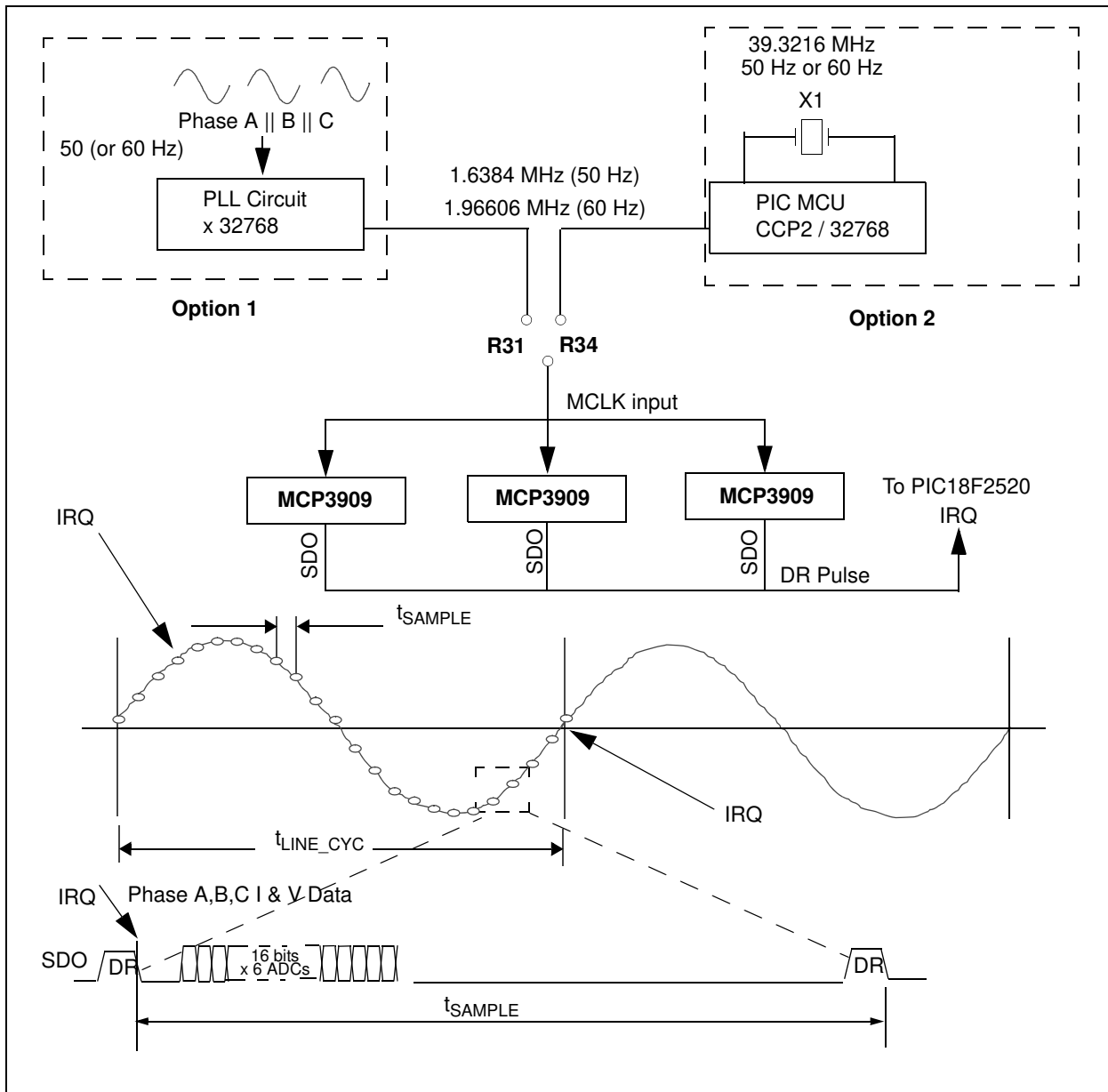

FIGURE 2-2: Timing Structure of PIC18F2520 Interrupts and Calculations.

2.3 METER OUTPUT

There are two outputs of the PIC18F2520, the CF calibration pulse and the RS-232 interface containing the register information. This meter design isolates both of these outputs using digital isolator U₁₃ and opto-isolator U₁₀. With the A_{GND} being referenced to the neutral line of 220V, a DC-DC converter is also included to isolate the power from P8, the output header. The output header, when used with the USB Interface Module, interfaces the meter to both the PC and the LCD on the USB interface module for output display.

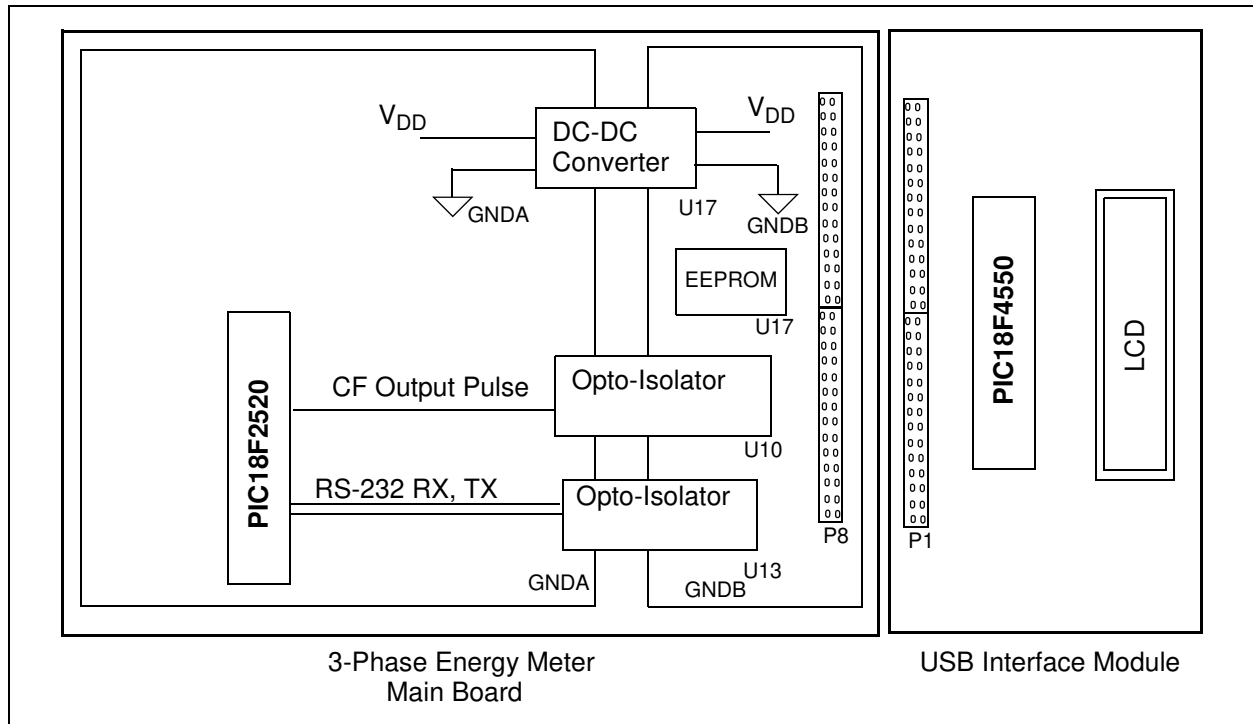

FIGURE 2-3: Meter Output Diagram.

MCP3909 3-Phase Energy Meter Reference Design

2.4 POWER SUPPLY CIRCUIT

The power supply circuit for the MCP3909 3-Phase Energy Meter Reference Design uses three voltage transformers to step down the 220V line voltages to the 5 volt regulator. The 2W maximum current consumption specification of the IEC62053 and legacy IEC61036 specifications limit the power supply voltage to a input voltage low enough to keep the power below this level.

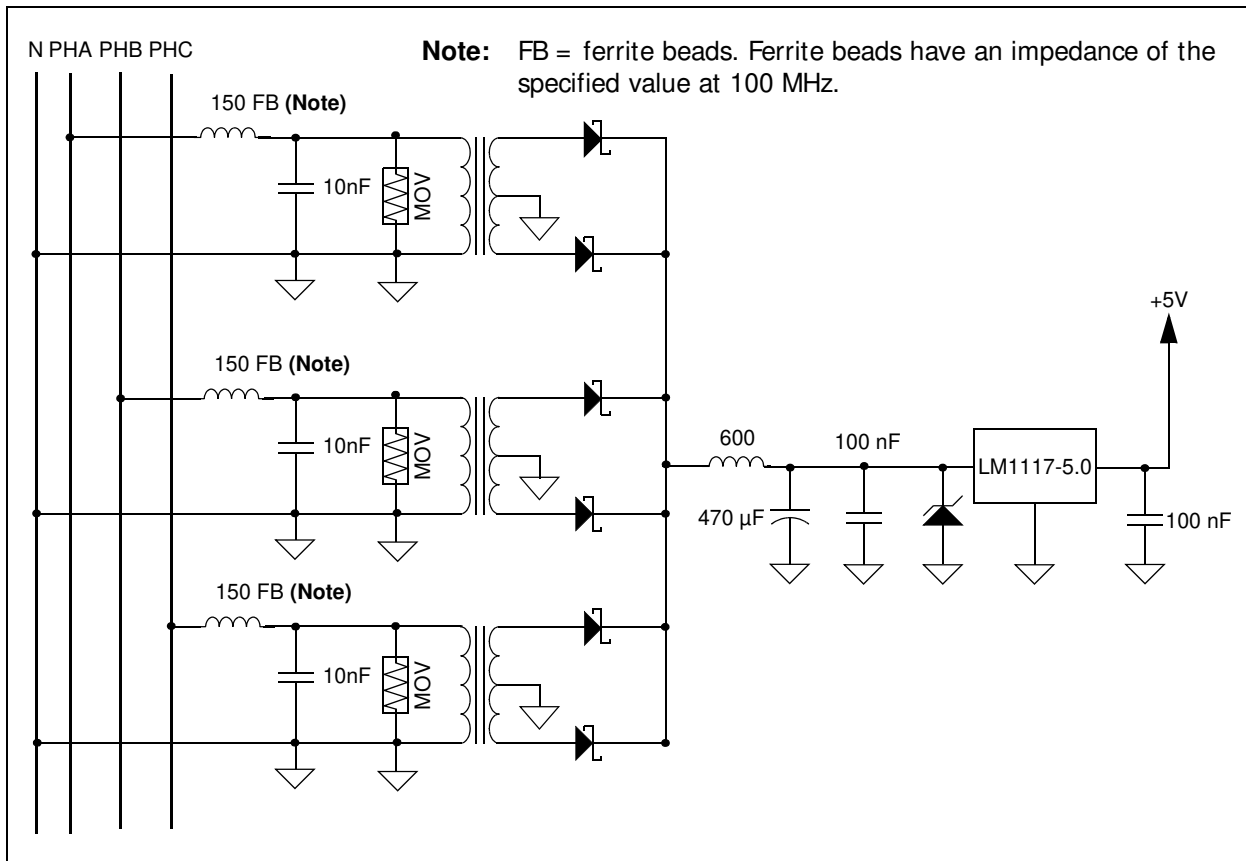

FIGURE 2-4: Power Supply Circuit. IEC62053 states that the meter must be able to operate from any single phase with 70% nominal voltage.

Chapter 3. PIC18F2520 Calculation and Register Description

3.1 REGISTER OVERVIEW

There are over 100 possible registers associated with the MCP3909 3-Phase Energy Meter Reference Design available via the RS-232 interlace on the PIC18F2520. The registers are named to describe each phase, specific measurement, and in the case of the calibration registers, the calibration function.

The intent of the calibration process is to yield output registers that are decimal representation of the final energy, power, current or voltage value.

RMS Current and Voltage Registers

The PHy_I_RMS registers, post calibration, contain the decimal representation of RMS current in A/LSB, 0.1A/LSB, or 0.01A/LSB. The PHy_V_RMS registers, post calibration, contain the decimal representation of RMS voltage in 0.1V/LSB. The final correction factor to convert these registers to these volts and amperes are located in the PHy_I_RMS_GLSB and PHy_V_RMS_GLSB registers. These correction factors can be automatically calculated and loaded by using the PC calibration software. The exact representation depends on the meter values that are entered in the software. For example, for a maximum current of 10A, the current is 0.01A/LSB.

Instantaneous Power Registers

The PHy_W and PHy_VA registers contain the decimal representation of the active power (W) and apparent power (VA) post calibration. The reactive power calculation is not implemented at this time.

The final correction factors to convert these registers to units of energy are located in the _GLSB registers. These correction factors can be automatically calculated and loaded by using the PC calibration software. The exact representation depends on the meter values that are entered in the software. For example, at 10A and 220V, power in the PHy_W register is 0.1 mW/LSB

Calibration Registers

The calibration registers fall into one of three categories: offset, gain, and LSB, denoted by _OFF, _GAIN and _GLSB register names.

In addition there are two registers, CFNUM and CFDEN, that calibrate the output pulse, CF.

PIC18F2520 Calculation and Register Description

3.3 COMPLETE REGISTER LIST

TABLE 3-1: INTERNAL REGISTER SUMMARY

Address	Name	Bits	R/W	Description
0x000	MODE1	16	R/W	Configuration register for operating mode of the meter
0x002	RESERVED	16	—	Reserved
0x004	STATUS1	16	R	Status Register
0x006	RESERVED	16	—	Reserved
0x008	CAL_CONTROL	16	R/W	Configuration register for calibration control
0x00A	LINE_CYC	16	R/W	2 ⁿ number of line cycles to be used during energy accumulation
0x00C	LINE_CYC_CNT	16	R	Counter for number of line cycles
0x00E	RESERVED	16	—	Reserved
0x010	PHA_I_RMS_RAW2	48	R	Raw ² RMS value from the phase A current A/D converter in LSBs
0x016	PHA_I_RMS_RAW	16	R	Raw RMS value from the phase A current A/D converter in LSBs
0x018	PHA_I_RMS	16	R	RMS value of phase A current (post calibration)
0x01A	PHA_V_RMS_RAW2	48	R	Raw ² RMS value from the phase A voltage A/D converter in LSBs
0x020	PHA_V_RMS_RAW	16	R	Raw RMS value from the phase A voltage A/D converter in LSBs
0x022	PHA_V_RMS	16	R	RMS value of phase A voltage (post calibration)
0x024	PHB_I_RMS_RAW2	48	R	Raw ² RMS value from the phase B current A/D converter in LSBs
0x02A	PHB_I_RMS_RAW	16	R	Raw RMS value from the phase B current A/D converter in LSBs
0x02C	PHB_I_RMS	16	R	RMS value of phase B current (post calibration)
0x02E	PHB_V_RMS_RAW2	48	R	Raw ² RMS value from the phase B voltage A/D converter in LSBs
0x034	PHB_V_RMS_RAW	16	R	Raw RMS value from the phase B voltage A/D converter in LSBs
0x036	PHB_V_RMS	16	R	RMS value of phase B voltage (post calibration)
0x038	PHC_I_RMS_RAW2	48	R	Raw ² RMS value from the phase C current A/D converter in LSBs
0x03E	PHC_I_RMS_RAW	16	R	Raw RMS value from the phase C current A/D converter in LSBs
0x040	PHC_I_RMS	16	R	RMS value of phase C current (post calibration)
0x042	PHC_V_RMS_RAW2	48	R	Raw ² RMS value from the phase C voltage A/D converter in LSBs
0x048	PHC_V_RMS_RAW	16	R	Raw RMS value from the phase C voltage A/D converter in LSBs
0x04A	PHC_V_RMS	16	R	RMS value of phase C voltage (post calibration)
0c04C	I_RMS	24	R	Sum of All Currents
0x04F	RESERVED	8	—	Reserved
0x050	NEUT_I_RMS_RAW2	48	R	Not implemented
0x056	NEUT_I_RMS_RAW	16	R	Not implemented
0x058	NEUT_I_RMS	16	R	Not implemented
0x05A	NEUT_V_RMS_RAW2	48	R	Not implemented
0x060	NEUT_V_RMS_RAW	16	R	Not implemented
0x062	NEUT_V_RMS	16	R	Not implemented
0x064	PHA_W_RAW	48	R	Raw phase A active power.
0x06A	PHB_W_RAW	48	R	Raw phase B active power
0x070	PHC_W_RAW	48	R	Raw phase C active power
0x076	PHA_W	32	R	Final Phase A active power, units in watts (W)
0x07A	PHB_W	32	R	Final Phase B active power, units in watts (W)
0x07E	PHC_W	32	R	Final Phase C active power, units in watts (W)
0x082	PHA_VA_RAW	48	R	Raw phase A apparent power
0x088	PHB_VA_RAW	48	R	Raw phase B apparent power
0x08E	PHC_VA_RAW	48	R	Raw phase C apparent power

MCP3909 3-Phase Energy Meter Reference Design

TABLE 3-1: INTERNAL REGISTER SUMMARY (CONTINUED)

Address	Name	Bits	R/W	Description
0x094	PHA_VA	32	R	Final Phase A apparent power, units in volt-amperes (VA)
0x098	PHB_VA	32	R	Final Phase B apparent power, units in volt-amperes (VA)
0x09C	PHC_VA	32	R	Final Phase C apparent power, units in volt-amperes (VA)
0x0A0	PHA_VAR_RAW	48	R	Not implemented
0x0A6	PHB_VAR_RAW	48	R	Not implemented
0x0AC	PHC_VAR_RAW	48	R	Not implemented
0x0B2	PHA_VAR	32	R	Not implemented
0x0B6	PHB_VAR	32	R	Not implemented
0x0BA	PHC_VAR	32	R	Not implemented
0x0BE	RESERVED	16	—	Not implemented
0x0C0	PERIOD	32	R	Period register
0x0C4	ENERGY_W	64	R	Total active energy accumulated
0x0CC	ENERGY_W_Z	64	R	Total active energy accumulated since last read of this register
0x0D4	ENERGY_W_L_RAW	48	R	Total energy accumulated over last LINE_CYC line cycles
0x0DA	ENERGY_W_L	32	R	Not implemented
0x0DE	ENERGY_VA	64	R	Total apparent energy accumulated
0x0E6	ENERGY_VA_Z	64	R	Total apparent energy accumulated since the last read of this register
0x0EE	ENERGY_VA_L_RAW	48	R	Total apparent energy accumulated over last LINE_CYC line cycles
0x0F4	ENERGY_VA_L	32	R	Not implemented
0x0F8	PHA_I_ABS_MAX	8	R	Maximum absolute value of phase A raw current
0x0F9	PHA_V_ABS_MAX	8	R	Maximum absolute value of phase A raw voltage
0x0FA	PHB_I_ABS_MAX	8	R	Maximum absolute value of phase B raw current
0x0FB	PHB_V_ABS_MAX	8	R	Maximum absolute value of phase B raw voltage
0x0FC	PHC_I_ABS_MAX	8	R	Maximum absolute value of phase C raw current
0x0FD	PHC_V_ABS_MAX	8	R	Maximum absolute value of phase C raw voltage
0x0FE	RESERVED	16	—	Reserved
0x100	ENERGY_VAR	64	R	Not implemented
0x108	ENERGY_VAR_Z	64	R	Not implemented
0x110	ENERGY_VAR_L_RAW	48	R	Not implemented
0x116	ENERGY_VAR_L	32	R	Not implemented
0x11A	Reserved	272	—	Reserved
0x13C	Reserved	16	—	Reserved
0x13E	Reserved	16	—	Reserved
0x13F	End	—	—	End of PIC18F2520 RAM
CALIBRATION REGISTERS				
0x140	PHA_DELAY	8	R/W	Phase A delay (delay between voltage and current, voltage is time shifted)
0x141	PHB_DELAY	8	R/W	Phase B delay (delay between voltage and current, voltage is time shifted)
0x142	PHC_DELAY	8	R/W	Phase C delay (delay between voltage and current, voltage is time shifted)
0x143	RESERVED	8	—	Reserved
0x144	PHA_I_RMS_OFF	16	R/W	Offset adjustment for phase A RMS current reading
0x146	PHA_V_RMS_OFF	16	R/W	Offset adjustment for phase A RMS voltage reading

PIC18F2520 Calculation and Register Description

TABLE 3-1: INTERNAL REGISTER SUMMARY (CONTINUED)

Address	Name	Bits	R/W	Description
0x148	PHB_I_RMS_OFF	16	R/W	Offset adjustment for phase B RMS current reading
0x14A	PHB_V_RMS_OFF	16	R/W	Offset adjustment for phase B RMS voltage reading
0x14C	PHC_I_RMS_OFF	16	R/W	Offset adjustment for phase C RMS current reading
0x14E	PHC_V_RMS_OFF	16	R/W	Offset adjustment for phase C RMS voltage reading
0x150	PHA_I_RMS_GAIN	16	R/W	Not implemented
0x152	PHA_V_RMS_GAIN	16	R/W	Not implemented
0x154	PHB_I_RMS_GAIN	16	R/W	Not implemented
0x156	PHB_V_RMS_GAIN	16	R/W	Not implemented
0x158	PHC_I_RMS_GAIN	16	R/W	Not implemented
0x15A	PHC_V_RMS_GAIN	16	R/W	Not implemented
0x15C	NEUT_I_RMS_GAIN	16	R/W	Not implemented
0x15E	NEUT_V_RMS_GAIN	16	R/W	Not implemented
0x160	PHA_I_RMS_GLSB	16	R/W	Gain adjustment for Phase A RMS current, to produce X A/LSB
0x162	PHA_V_RMS_GLSB	16	R/W	Gain adjustment for Phase A RMS voltage, to produce X V/LSB
0x164	PHB_I_RMS_GLSB	16	R/W	Gain adjustment for Phase B RMS current, to produce X A/LSB
0x166	PHB_V_RMS_GLSB	16	R/W	Gain adjustment for Phase B RMS voltage, to produce X V/LSB
0x168	PHC_I_RMS_GLSB	16	R/W	Gain adjustment for Phase C RMS current, to produce X A/LSB
0x16A	PHC_V_RMS_GLSB	16	R/W	Gain adjustment for Phase C RMS voltage, to produce X V/LSB
0x16C	NEUT_I_RMS_GLSB	16	R/W	Not implemented
0x16E	NEUT_V_RMS_GLSB	16	R/W	Not implemented
0x170	PHA_W_OFF	32	R/W	Active power offset, Phase A
0x174	PHB_W_OFF	32	R/W	Active power offset, Phase B
0x178	PHC_W_OFF	32	R/W	Active power offset, Phase C
0x17C	PHA_W_GAIN	16	R/W	Active power gain adjust for Phase A, for CF matching
0x17E	PHB_W_GAIN	16	R/W	Active power gain adjust for Phase B, for CF matching
0x180	PHC_W_GAIN	16	R/W	Active power gain adjust for Phase C, for CF matching
0x182	PHA_W_GLSB	16	R/W	Active power gain adjust for Phase A, to produce X W/LSB
0x184	PHB_W_GLSB	16	R/W	Active power gain adjust for Phase B, to produce X W/LSB
0x186	PHC_W_GLSB	16	R/W	Active power gain adjust for Phase C, to produce X W/LSB
0x188	PHA_VA_GAIN	16	R/W	Apparent power gain adjust for Phase A
0x18A	PHB_VA_GAIN	16	R/W	Apparent power gain adjust for Phase B
0x18C	PHC_VA_GAIN	16	R/W	Apparent power gain adjust for Phase C
0x18E	PHA_VA_GLSB	16	R/W	Apparent power gain adjust for Phase A, to produce X VA/LSB
0x190	PHB_VA_GLSB	16	R/W	Apparent power gain adjust for Phase B, to produce X VA/LSB
0x192	PHC_VA_GLSB	16	R/W	Apparent power gain adjust for Phase C, to produce X VA/LSB
0x194	PHA_VAR_GAIN	16	R/W	Not implemented
0x196	PHB_VAR_GAIN	16	R/W	Not implemented
0x198	PHC_VAR_GAIN	16	R/W	Not implemented
0x19A	PHA_VAR_GLSB	16	R/W	Not implemented
0x19C	PHB_VAR_GLSB	16	R/W	Not implemented
0x19E	PHC_VAR_GLSB	16	R/W	Not implemented
0x1A0	ENERGY_W_GLSB	16	R/W	Not implemented
0x1A2	ENERGY_VA_GLSB	16	R/W	Not implemented
0x1A4	ENERGY_VAR_GLSB	16	R/W	Not implemented
0x1A6	CREEP_THRESH	32	R/W	Not implemented

MCP3909 3-Phase Energy Meter Reference Design

TABLE 3-1: INTERNAL REGISTER SUMMARY (CONTINUED)

Address	Name	Bits	R/W	Description
0x1AA	CF_PULSE_WIDTH	8	R/W	Defines CF pulse width from 0 to 255 * 1.25 ms for 50 Hz. For 60 Hz line 0 to 255 * 1.042 ms.
0x1AB	RESERVED	8	—	Reserved
0x1AC	CFDEN	8	R/W	CF Calibration Pulse correction factor
0x1AD	RESERVED	8	—	Reserved
0x1AE	CFNUM	16	R/W	CF Calibration Pulse correction factor
0x1B0	MODE1DEF	16	R/W	Power Up Configuration Register
0x1B2	PHA_CAL_STATUS	16	R/W	Status of Phase A Calibration
0x1B4	PHB_CAL_STATUS	16	R/W	Status of Phase B Calibration
0x1B6	PHC_CAL_STATUS	16	R/W	Status of Phase C Calibration
0x1B8	STAND_W_RAW	48	R/W	Standard Phase Active Power Reading (place holder register used during calibration for gain matching)

PIC18F2520 Calculation and Register Description

3.4 CONFIGURATION AND OUTPUT REGISTERS

3.4.1 MODE1 Register

REGISTER 3-1: MODE1 Register

Name	Bits	Address	Cof
MODE1	16	0x000	R/W

The mode register controls the operation of the energy meter. The bit functions are defined by the table below.

R/W-0	R/W	R/W	R/W	R/W	U-0	U-0	U-0
APP2	APP1	APP0	ACT1	ACT0	—	—	—
bit 15					bit 8		

R/W	R/W	R/W	R/W	R/W	R/W	R/W	R/W
PGA1	PGA0	CF_C	CF_B	CF_A	ABSOLUTE	PHASE	CREEP
bit 7					bit 0		

Legend:

R = Readable bit	W = Writable bit	U = Unimplemented bit, read as '0'
-n = Value at POR	'1' = Bit is set	'0' = Bit is cleared
		x = Bit is unknown

- bit 13-15 **APP:** Apparent Power Calculation Mode Bits (not implemented)
- bit 11-12 **ACT:** Active Power Calculation Mode Bits (not implemented)
- bit 8-10 **Unimplemented:** Read as '0'
- bit 6-7 **PGA:** PGA Bits (not implemented)
- bit 3-5 **CF Phase y:** Active Energy CF Phase Enable Bits
 - 1 = Enabled to be accumulated into the total energy registers or CF pulse output
 - 0 = Disabled and is not accumulated into the total energy registers or CF pulse output
- bit 2 **Absolute:** Positive Only Energy Accumulation Mode
 - 1 = Positive Energy Only
 - 0 = Both negative and positive energy accumulated (negative energy is subtracted)
- bit 1 **Phase:** The Phase Bit
 - 1 = Single Point Phase Correction
 - 0 = Multi-Point Phase Correction (future)
- bit 0 **CREEP:** No-Load Threshold Bit
 - 1 = Enabled
 - 0 = Disabled

MCP3909 3-Phase Energy Meter Reference Design

3.4.2 STATUS1 Register

REGISTER 3-2: STATUS1 Register

Name	Bits	Address	Cof
STATUS1	16	0x004	R

The STATUS1 register contains the operational status of the energy meter. The bit functions are defined by the table below.

U-0	U-0	U-0	U-0	U-0	U-0	U-0	U-0
—	—	—	—	—	—	—	—
bit 15							bit 8

U-0	U-0	U-0	U-0	U-0	R	R	R
—	—	—	—	—	PHA_S	PHB_S	PHC_S
bit 7						bit 0	

Legend:

R = Readable bit	W = Writable bit	U = Unimplemented bit, read as '0'
-n = Value at POR	'1' = Bit is set	'0' = Bit is cleared x = Bit is unknown

- bit 15-3 **Unimplemented:** Read as '0'
- bit 2 **PHA_S:** Phase A Sign Bit. This is the sign bit of raw active power before absolute value taken (if enabled, see MODE1 bits).
 - 1 = Negative active power, this may indicate the CT is wired in backwards
 - 0 = Operation Normal
- bit 1 **PHB_S:** Phase B Sign Bit. This is the sign bit of raw active power before absolute value taken (if enabled, see MODE1 bits).
 - 1 = Negative active power, this may indicate the CT is wired in backwards
 - 0 = Operation Normal
- bit 0 **PHC_S:** Phase C Sign Bit. This is the sign bit of raw active power before absolute value taken (if enabled, see MODE1 bits).
 - 1 = Negative active power, this may indicate the CT is wired in backwards
 - 0 = Operation Normal

PIC18F2520 Calculation and Register Description

3.4.3 CAL_CONTROL Register

REGISTER 3-3: CAL_CONTROL Register

Name	Bits	Address	Cof
CAL_CONTROL	16	0x008	R/W

This is the calibration mode control register. Bit 0 enables calibration mode. When bit 1 is set high, the energy accumulation registers are updated for LINE_CYC line cycles. After this time, bit 1 is set low by the PIC18F2520 and the update of the energy accumulation registers will stop. This allows the calibration software to set bit 0, clear the registers, set bit 1, and then start reading the energy accumulation registers as well as this register to check the status of bit 1. When bit 1 goes low, then LINE_CYC lines cycles have passed and the energy accumulation registers are final. Note that bit 0 takes effect immediately and bit 1 will take effect on the very next line cycle. When bit 1 goes low, all energy accumulation registers will be ready to read. While in calibration mode, those registers that are used as part of the meter calibration and normally dependent on calibration registers will not be dependent while in calibration mode. For example, PHA_W_RAW is not dependent on PHA_W_OFF in calibration mode.

U-0	U-0	U-0	U-0	U-0	U-0	U-0	U-0
—	—	—	—	—	—	—	—
bit 15						bit 8	

U-0	U-0	U-0	U-0	U-0	U-0	R/W-0	R/W-0
—	—	—	—	—	Reserved	CAL_Update	Cal_Mode
bit 7						bit 0	

Legend:

R = Readable bit W = Writable bit U = Unimplemented bit, read as '0'
 -n = Value at POR '1' = Bit is set '0' = Bit is cleared x = Bit is unknown

bit 15-3 **Unimplemented:** Read as '0'

bit 2 **Reserved:**

bit 1 **CAL_UPDATE:** Calibration Update Bit

Power and energy registers updated for LINE_CYC line cycles when set. Bit must be set for registers to begin updating, which starts on the next line cycle after bit is set.

1 = When CAL_MODE bit is set, set this bit to enable update of power and energy registers starting on next line cycle

0 = When CAL_MODE bit is set and this bit has been set, this bit will be cleared after LINE_CYC line cycles. At that point, all registers will be updated, and no further updates will be done until this bit is set again or CAL_MODE bit is cleared

bit 0 **CAL_MODE:** Calibration Mode Bit

This bit enables calibration mode.

1 = Calibration Mode Enabled

0 = Calibration Mode Disabled

MCP3909 3-Phase Energy Meter Reference Design

3.4.4 LINE_CYC

REGISTER 3-4: LINE_CYC REGISTERS

Name	Bits	Address	Cof
LINE_CYC	16	0x00A	R/W

Number of line cycles as a power of two. A setting of 0 indicates 2^0 or 1 line cycle. A setting of 1 is 2 line cycles (2^1), a setting of 2 is 4 lines cycles (2^2), up to a setting of 8 which is 256 line cycles. When written, this register will not take effect until the previous number of line cycles has been acquired.

3.4.5 LINE_CYC_CNT

REGISTER 3-5: LINE_CYC_CNT REGISTER

Name	Bits	Address	Cof
LINE_CYC_CNT	16	0x00C	R

This register counts from 0 and finishes at $2^{(\text{LINE_CYC})} - 1$ and then re-starts at 0, where LINE_CYC represents the value in the LINE_CYC register.

3.4.6 PHy_I_RMS_RAW2

REGISTER 3-6: PHY_I_RMS_RAW2 REGISTERS

Name	Bits	Address	Cof
PHA_I_RMS_RAW2	48	0x010	R
PHB_I_RMS_RAW2	48	0x024	R
PHC_I_RMS_RAW2	48	0x038	R

These registers are the square of the raw RMS value from the phase y current A/D converter in LSBs. By definition, these registers will always contain a positive value, including the situation where power is negative from a backwards CT or otherwise. These registers are overwritten every LINE_CYC line cycles and are written only once if calibration is enabled.

3.4.7 PHy_I_RMS_RAW

REGISTER 3-7: PHY_I_RMS_RAW REGISTERS

Name	Bits	Address	Cof
PHA_I_RMS_RAW	16	0x016	R
PHB_I_RMS_RAW	16	0x02A	R
PHC_I_RMS_RAW	16	0x03E	R

These registers are the raw RMS value from the phase y current A/D converter in LSBs (square root of the top 32-bits of (PHA_I_RMS_RAW2 + PHA_I_RMS_OFF)). By definition, these registers will always contain a positive value (even if the CT is in backwards). These registers are overwritten every LINE_CYC line cycles and are written only once if calibration is enabled.

PIC18F2520 Calculation and Register Description

3.4.8 PHy_I_RMS

REGISTER 3-8: PHY_I_RMS REGISTERS

Name	Bits	Address	Cof
PHA_I_RMS	16	0x018	R
PHB_I_RMS	16	0x02C	R
PHC_I_RMS	16	0x040	R

These registers are the RMS value of phase y current in X A/LSB, as determined by the value in the PHA_I_RMS_GLSB register. When displaying the RMS current for phase y, simply display the (decimal) value in these registers with the decimal point two digits in from the right. (Note this decimal point location of 0.01A LSB resolution is specific for the 5(10)A, 220V rating that this meter is designed for). These registers are overwritten every LINE_CYC line cycles (written only once if calibration is enabled).

3.4.9 PHy_V_RMS_RAW2

REGISTER 3-9: PHY_V_RMS_RAW2 REGISTERS

Name	Bit	Address	Cof
PHA_V_RMS_RAW2	48	0x01A	R
PHB_V_RMS_RAW2	48	0x02E	R
PHC_V_RMS_RAW2	48	0x042	R

These registers are the square of the raw RMS value from the phase A voltage A/D converter in LSBs. By definition, they will always contain a positive value. These registers are overwritten every LINE_CYC line cycles (written only once if calibration is enabled).

3.4.10 PHy_V_RMS_RAW

REGISTER 3-10: PHY_V_RMS_RAW REGISTERS

Name	Bits	Address	Cof
PHA_V_RMS_RAW	16	0x020	R
PHB_V_RMS_RAW	16	0x034	R
PHC_V_RMS_RAW	16	0x048	R

This is the raw RMS value from the phase y voltage A/D converter in LSBs (square root of the top 32-bits of PHA_V_RMS_RAW2 + PHA_V_RMS_OFF). By definition, these registers will always contain a positive value. Each of these registers is overwritten every LINE_CYC line cycles (written only once if calibration is enabled).

3.4.11 PHy_V_RMS

REGISTER 3-11: PHY_V_RMS REGISTERS

Name	Bits	Address	Cof
PHA_V_RMS	16	0x022	R
PHB_V_RMS	16	0x036	R
PHC_V_RMS	16	0x04A	R

These registers are the RMS value of phase y voltage, in X 0.1V/LSB, as determined by the value in the PHy_V_RMS_GLSB register. When displaying the RMS voltage for phase y, simply display the value in these registers with the decimal point one digit in from the right. (Note this decimal point location, or LSB resolution of 0.1V, is specific for the 5(10)A, 220V rating that this meter is designed for). These registers are overwritten every LINE_CYC line cycles (written only once if calibration is enabled).

MCP3909 3-Phase Energy Meter Reference Design

3.4.12 I_RMS

REGISTER 3-12: I_RMS REGISTER

Name	Bits	Address	Cof
I_RMS	24	0x04C	R

This is the sum of all currents (note: algebraic sum of PHA_I_RMS, PHB_I_RMS, and PHC_I_RMS, NOT RMS sum). This value should equal X A/LSB. When displaying total RMS current, simply display the (decimal) value in this register with the decimal point two digits in from the right. (Note this decimal point location of 0.01A LSB resolution is specific for the 5(10)A, 220V rating that this meter is designed for). This register is overwritten every LINE_CYC line cycles (written only once if calibration is enabled).

3.4.13 PHy_W_RAW

REGISTER 3-13: PHy_W_RAW REGISTERS

Name	Bits	Address	Cof
PHA_W_RAW	48	0x064	R
PHB_W_RAW	48	0x06A	R
PHC_W_RAW	48	0x070	R

These registers are the raw phase y active power as it represents the sum of each phase y current A/D value times phase y voltage A/D value results over LINE_CYC line cycles (each line cycle has 128 results). Each current times voltage multiplication results in a 32-bit word. There are up to 256 line cycles with each line cycle being 128 results and each result being 32-bit. Thus, a 48-bit register is needed. This is the register to be read during calibration for calculating the offset and gain values associated with active phase y power, PHy_W_OFF, PHy_W_GAIN, and PHy_W_GLSB. These registers are overwritten every line cycle, however if calibration is enabled, updates will stop once LINE_CYC line cycles have elapsed.

3.4.14 PHy_W

REGISTER 3-14: PHy_W REGISTERS

Name	Bits	Address	Cof
PHA_W	32	0x076	R
PHB_W	32	0x07A	R
PHC_W	32	0x07E	R

These registers are the value for phase y active power. The goal of calibration is to get these registers values to equal X 0.1 mW/LSB. When displaying the active power for phase y, simply display the value in these registers with the decimal point one digit in from the right, in milli-watts. (Note this decimal point location, or LSB resolution of 0.1 mW, is specific for the 5(10)A, 220V rating that this meter is designed for). This register is overwritten every LINE_CYC line cycles (written only once if calibration is enabled).

PIC18F2520 Calculation and Register Description

3.4.15 PHY_VA_RAW

REGISTER 3-15: PHY_VA_RAW REGISTERS

Name	Bits	Address	Cof
PHA_VA_RAW	48	0x082	R
PHB_VA_RAW	48	0x088	R
PHC_VA_RAW	48	0x08E	R

These registers are the raw phase y apparent power. Unlike active power, this is simply the multiplication of voltage (PHY_V_RMS) times current (PHY_I_RMS). This is the register that should be read during calibration for calculating the gain values associated with apparent phase A power, PHY_VA_GAIN and PHY_VA_GLSB. This register is overwritten every LINE_CYC line cycles (written only once if calibration is enabled).

3.4.16 PHY_VA

REGISTER 3-16: PHY_VA REGISTERS

Name	Bits	Address	Cof
PHA_VA	32	0x094	R
PHB_VA	32	0x098	R
PHC_VA	32	0x09C	R

This is the value for phase y apparent power. The goal of calibration is to get this value to equal X 0.1 mVA/LSB. This is done with the PHY_VA_GLSB registers. When displaying the apparent power for phase y, simply display the value in these registers with the decimal point one digit in from the right, in milli-volt-amperes. (Note this decimal point location, or LSB resolution of 0.1 mVA, is specific for the 5(10)A, 220V rating that this meter is designed for). This register is overwritten every LINE_CYC line cycles (written only once if calibration is enabled).

3.4.17 PHY_VAR_RAW (NOT IMPLEMENTED)

REGISTER 3-17: PHY_VAR_RAW REGISTERS

Name	Bits	Address	Cof
PHA_VAR_RAW	48	0x0A0	R
PHB_VAR_RAW	48	0x0A6	R
PHC_VAR_RAW	48	0x0AC	R

This is the raw phase y reactive power. This is the register to be read during calibration for calculating the gain values associated with reactive phase y power, PHY_VAR_GAIN and PHY_VAR_GLSB. This register is overwritten every LINE_CYC line cycles (written only once if calibration is enabled).

NOT IMPLEMENTED IN THIS FIRMWARE/SOFTWARE RELEASE.

MCP3909 3-Phase Energy Meter Reference Design

3.4.18 PHY_VAR (NOT IMPLEMENTED)

REGISTER 3-18: PHY_VAR REGISTERS

Name	Bits	Address	Cof
PHA_VAR	32	0x0B2	R
PHB_VAR	32	0x0B6	R
PHC_VAR	32	0x0BA	R

This is the value for phase y reactive power. The goal is to get this value to equal X VAR/LSB. This is done with the PHY_VAR_GLSB registers. When displaying the reactive power for phase y, simply display the value in these registers with the decimal point one digit in from the right, in milli-volt-amperes-reactive. (Note this decimal point location, or LSB resolution of 0.1 mVAR, is specific for the 5(10)A, 220V rating that this meter is designed for). This register is overwritten every LINE_CYC line cycles (written only once if calibration is enabled).

NOT IMPLEMENTED IN THIS FIRMWARE/SOFTWARE RELEASE.

3.4.19 PERIOD

REGISTER 3-19: PERIOD REGISTER

Name	Bits	Address	Cof
PERIOD	32	0x0C0	R

This 32-bit register represents the total number of clock ticks that elapsed over the most recent LINE_CYC line cycles. Each LSB represents 1.6 us with a 40 MHz clock on the microcontroller. This register is overwritten every LINE_CYC line cycles (written only once if calibration is enabled).

PIC18F2520 Calculation and Register Description

3.4.20 ENERGY_W_

REGISTER 3-20: ENERGY_W_ REGISTERS

Name	Bits	Address	Cof
ENERGY_W	64	0x0C4	R
ENERGY_W_Z	64	0x0CC	R
ENERGY_W_L	32	0x0DA	R
ENERGY_W_L_RAW	48	0x0D4	R

These four registers represent the total active energy accumulated. The ENERGY_W_L_RAW register is the total active energy accumulated over the previous LINE_CYC line cycles.

Accumulation is done every line cycle and is:

EQUATION 3-1:

$$\begin{aligned} \text{ENERGY_W} = & \text{ENERGY_W} + \left[(\text{PHA_W_RAW} + \text{PHA_W_OFF}) \cdot \left(\frac{\text{PHA_W_GAIN}}{32768} \right) \right. \\ & + (\text{PHB_W_RAW} + \text{PHB_W_OFF}) \cdot \left(\frac{\text{PHB_W_GAIN}}{32768} \right) \\ & \left. + (\text{PHC_W_RAW} + \text{PHC_W_OFF}) \cdot \left(\frac{\text{PHC_W_GAIN}}{32768} \right) \right] \cdot \frac{\text{PERIOD}}{65536} \end{aligned}$$

Where:

PERIOD = the period (in 1.6 μ s clock ticks) for the most recent line cycle.

During calibration, ENERGY_W_Z, ENERGY_W, and ENERGY_W_L_RAW will all have the same value.

Also, during calibration, the PHy_W_OFF register additions are skipped and the PHy_W_GAIN values are all set to their default value of 0x4000 (16,384).

The ENERGY_W_L_RAW register is the register that should be read when calibrating CFNUM and CFDEN.

This register is updated every line cycle (updating ends once LINE_CYC line cycles have passed if calibration is enabled).

MCP3909 3-Phase Energy Meter Reference Design

3.4.21 ENERGY_VA_

REGISTER 3-21: ENERGY_VA_ REGISTERS

Name	Bits	Address	Cof
ENERGY_VA	64	0x0DE	R
ENERGY_VA_Z	64	0x0E6	R
ENERGY_VA_L	32	0x0F4	R
ENERGY_VA_L_RAW	48	0x0EE	R

These four registers represent the total apparent energy accumulated so far. Energy from each LINE_CYC line cycles is:

EQUATION 3-2:

$$\begin{aligned} \text{ENERGY_VA} = & \text{ENERGY_VA} + \left[(\text{PHA_I_RMS_RAW} \bullet \text{PHA_V_RMS_RAW}) \bullet \left(\frac{\text{PHA_VA_GAIN}}{32768} \right) \right. \\ & + (\text{PHB_I_RMS_RAW} \bullet \text{PHB_V_RMS_RAW}) \bullet \left(\frac{\text{PHB_VA_GAIN}}{32768} \right) \\ & \left. + (\text{PHC_I_RMS_RAW} \bullet \text{PHC_V_RMS_RAW}) \bullet \left(\frac{\text{PHC_VA_GAIN}}{32768} \right) \right] \bullet \frac{\text{PERIOD} \bullet 128}{65536} \end{aligned}$$

Where:

PERIOD = the period (in 1.6 μ s clock ticks) for the most recent LINE_CYC line cycles.

Note that during calibration, this value, ENERGY_VA_Z, and ENERGY_VA_L_RAW will all have the same value.

This register is updated every LINE_CYC line cycles (updating ends after first update if calibration is enabled).

PIC18F2520 Calculation and Register Description

3.4.22 PHy_I_ABS_MAX

REGISTER 3-22: PHY_I_ABS_MAX REGISTER

Name	Bit	Address	Cof
PHA_I_ABS_MAX	8	0x0F8	R
PHB_I_ABS_MAX	8	0x0FA	R
PHC_I_ABS_MAX	8	0x0FC	R

Maximum absolute value of phase y raw current, where y is A, B, or C.

3.4.23 PHy_V_ABS_MAX

REGISTER 3-23: PHY_V_ABS_MAX REGISTER

Name	Bit	Address	Cof
PHA_V_ABS_MAX	8	0x0F9	R/W
PHB_V_ABS_MAX	8	0x0FB	R/W
PHC_V_ABS_MAX	8	0x0FD	R/W

Maximum absolute value of phase y raw voltage, where y is A, B, or C. This register can be used to check if all three phases are at nominal voltage or if there is a sag in the voltage of one or more phases.

3.4.24 ENERGY_VAR (NOT IMPLEMENTED)

REGISTER 3-24: ENERGY_VAR REGISTER

Name	Bit	Address	Cof
ENERGY_VAR	64	0x100	R
ENERGY_VAR_Z	64	0x108	R
ENERGY_VAR_L	32	0x116	R
ENERGY_VAR_L_RAW	48	0x110	R

NOT IMPLEMENTED IN THIS FIRMWARE/SOFTWARE RELEASE.

MCP3909 3-Phase Energy Meter Reference Design

3.5 CALIBRATION REGISTERS

The calibration register set contains all of the offset, gain, LSB adjust, phase delay, and calibration output pulse adjustment settings. The values to be placed in these configuration registers come during meter calibration and can be automatically generated using the “3-Phase Meter Calibration Software” available for download on Microchip’s website.

3.5.1 PHY_DELAY

REGISTER 3-25: PHY_DELAY REGISTER

Name	Bit	Address	Cof
PHA_DELAY	8	0x140	R/W
PHB_DELAY	8	0x141	R/W
PHC_DELAY	8	0x142	R/W

Phase y delay, signed 8-bit value, ± 2.8125 degrees ($\pm 130 \mu\text{s}$ for 60 Hz, $\pm 156 \mu\text{s}$ for 50 Hz)

3.5.2 PHY_I_RMS_OFF

REGISTER 3-26: PHY_I_RMS_OFF REGISTER

Name	Bit	Address	Cof
PHA_I_RMS_OFF	16	0x144	R/W
PHB_I_RMS_OFF	16	0x148	R/W
PHC_I_RMS_OFF	16	0x14A	R/W

Square of offset for phase y RMS current reading, signed 16-bit value. Note that this value should be similar to the ADCs noise squared. At a gain of 1, the noise will be about 1 LSB, 2 LSBs at a gain of 2 and 6 LSBs at a gain of 8 and 11 LSBs at a gain of 16. There may be other sources of noise. Using the square of the offset allows for higher accuracy. The value will be added before the square root is taken when calculating the final RMS value.

3.5.3 PHY_V_RMS_OFF

REGISTER 3-27: PHY_V_RMS_OFF REGISTER

Name	Bit	Address	Cof
PHA_V_RMS_OFF	16	0x146	R/W
PHB_V_RMS_OFF	16	0x14A	R/W
PHC_V_RMS_OFF	16	0x14E	R/W

Square of offset for phase y RMS voltage reading, signed 8-bit value. Note that this value should be similar to the ADCs noise squared. For the voltage channel, the noise will be about 1 LSB. There may be other sources of noise. Using the square of the offset allows for higher accuracy. The value will be added before the square root is taken when calculating the final RMS value.

3.5.4 PHY_I_RMS_GAIN (NOT IMPLEMENTED)

NOT IMPLEMENTED IN THIS FIRMWARE/SOFTWARE RELEASE.

3.5.5 PHY_V_RMS_GAIN (NOT IMPLEMENTED)

NOT IMPLEMENTED IN THIS FIRMWARE/SOFTWARE RELEASE.

PIC18F2520 Calculation and Register Description

3.5.6 PHy_I_RMS_GLSB

REGISTER 3-28: PHY_I_RMS_GLSB REGISTERS

Name	Bits	Address	Cof
PHA_I_RMS_GLSB	16	0x160	R/W
PHB_I_RMS_GLSB	16	0x164	R/W
PHC_I_RMS_GLSB	16	0x168	R/W

Phase y current gain to produce 0.01A/LSB. The value is always less than one (for example, $32,767 = 0.9999695$). (Note this decimal point location, or LSB resolution of 0.01A, is specific for the 5(10)A, 220V rating that this meter is designed for).

3.5.7 PHy_V_RMS_GLSB

REGISTER 3-29: PHY_V_RMS_GLSB REGISTERS

Name	Bits	Address	Cof
PHA_V_RMS_GLSB	16	0x162	R/W
PHB_V_RMS_GLSB	16	0x166	R/W
PHC_V_RMS_GLSB	16	0x16A	R/W

Phase y voltage gain to produce 0.1 V/LSB in the PHA_Y_V_RMS register. The value is always less than one (for example, $32,767 = 0.9999695$). (Note this decimal point location, or LSB resolution of 0.1V, is specific for the 5(10)A, 220V rating that this meter is designed for).

3.5.8 PHy_W_OFF

REGISTER 3-30: PHY_W_OFF REGISTERS

Name	Bits	Address	Cof
PHA_W_OFF	32	0x170	R/W
PHB_W_OFF	32	0x174	R/W
PHC_W_OFF	32	0x178	R/W

Phase y active power offset (this is straight offset, not the square as with voltage and current). A much larger value is need because the power is a running sum. This is a 32-bit signed value.

3.5.9 PHy_W_GAIN

REGISTER 3-31: PHY_W_GAIN REGISTERS

Name	Bits	Address	Cof
PHA_W_GAIN	16	0x17C	R/W
PHB_W_GAIN	16	0x17E	R/W
PHC_W_GAIN	16	0x180	R/W

Phase y active power gain so that all results can be calibrated to produce equal CF pulses/watt-hour. The signed 16-bit number produces a change in the PHy_W_RAW value before being added to the energy registers. A value of 32,767 represents a 99.9939% increase while a value of 8192 represents a decrease of 50%.

MCP3909 3-Phase Energy Meter Reference Design

3.5.10 PHy_W_GLSB

REGISTER 3-32: PHY_W_GLSB REGISTERS

Name	Bits	Address	Cof
PHA_W_GLSB	16	0x182	R/W
PHB_W_GLSB	16	0x184	R/W
PHC_W_GLSB	16	0x186	R/W

Phase y active power gain to produce X W/LSB. The value is always less than one (for example, $32,767 = 0.9999695$).

3.5.11 PHy_VA_GAIN

REGISTER 3-33: PHY_VA_GAIN REGISTERS

Name	Bits	Address	Cof
PHA_VA_GAIN	16	0x188	R/W
PHB_VA_GAIN	16	0x18A	R/W
PHC_VA_GAIN	16	0x18C	R/W

Phase y apparent power gain so that all results can be calibrated to produce equal VA hours. The signed 16-bit number produces a change in the PHy_VA_RAW value before being added to the energy registers. A value of 32,767 represents a 99.9939% increase while a value of 8192 represents a decrease of 50%.

3.5.12 PHy_VA_GLSB

REGISTER 3-34: PHY_VA_GLSB REGISTERS

Name	Bits	Address	Cof
PHA_VA_GLSB	16	0x18E	R/W
PHB_VA_GLSB	16	0x190	R/W
PHC_VA_GLSB	16	0x192	R/W

Phase y apparent power gain to produce X 0.1 mVA/LSB. The value is always less than one (for example, $32,767 = 0.9999695$).

3.5.13 PHy_VAR_GAIN (NOT IMPLEMENTED)

NOT IMPLEMENTED IN THIS FIRMWARE/SOFTWARE RELEASE.

3.5.14 PHy_VAR_GLSB (NOT IMPLEMENTED)

NOT IMPLEMENTED IN THIS FIRMWARE/SOFTWARE RELEASE.

3.5.15 ENERGY_W_GLSB (NOT IMPLEMENTED)

REGISTER 3-35: ENERGY_W_GLSB REGISTERS

Name	Bits	Address	Cof
ENERGY_W_GLSB	16	0x1A0	R/W

NOT IMPLEMENTED IN THIS FIRMWARE/SOFTWARE RELEASE.

PIC18F2520 Calculation and Register Description

3.5.16 ENERGY_VA_GLSB (NOT IMPLEMENTED)

REGISTER 3-36: ENERGY_VA_GLSB REGISTER

Name	Bits	Address	Cof
ENERGY_VA_GLSB	16	0x1A2	R/W

NOT IMPLEMENTED IN THIS FIRMWARE/SOFTWARE RELEASE.

3.5.17 ENERGY_VAR_GLSB (NOT IMPLEMENTED)

REGISTER 3-37: ENERGY_VAR_GLSB REGISTER

Name	Bits	Address	Cof
ENERGY_VAR_GLSB	16	0x1A4	R/W

NOT IMPLEMENTED IN THIS FIRMWARE/SOFTWARE RELEASE.

3.5.18 CREEP_THRESH (NOT IMPLEMENTED)

REGISTER 3-38: CREEP_THRESH REGISTER

Name	Bits	Address	Cof
CREEP_THRESH	32	0x1A6	R/W

NOT IMPLEMENTED IN THIS FIRMWARE/SOFTWARE RELEASE.

3.5.19 CF_PULSE_WIDTH

REGISTER 3-39: CF_PULSE_WIDTH REGISTER

Name	Bits	Address	Cof
CF_PULSE	8	0x1AA	R/W

Defines CF pulse width from 0 to 255. Length of width is value * 8 * (1/LINEFREQ) / 128) ms. A maximum of 0.266 seconds for 60 Hz and 0.319 seconds for 50 Hz.

If the value is 0, no CF pulse is produced.

3.5.20 CFDEN

REGISTER 3-40: CFDEN REGISTER

Name	Bits	Address	Cof
CF_DEN	16	0x1AC	R/W

8-bit signed value. Represents the number of shifts for active power energy register ENERGY_W_L before CFNUM is applied.

3.5.21 CFNUM

REGISTER 3-41: CFNUM REGISTER

Name	Bits	Address	Cof
CF_NUM	16	0x1AE	R/W

Active power gain to produce a specified pulses per watt-hour. The value is always less than one (for example, 32,767 = 0.9999695).

MCP3909 3-Phase Energy Meter Reference Design

3.5.22 MODE1_DEF

REGISTER 3-42: MODE1_DEF REGISTER

Name	Bits	Address	Cof
MODE1_DEF	16	0x1B0	R/W

Mode 1 default power-up settings. On power-up, this register will be read and placed into the MOD1 register.

3.5.23 PHY_CAL_Status Register

REGISTER 3-43: PHY_CAL_STATUS REGISTERS

Name	Bits	Address	Cof
PHA_CAL_STATUS	16	0x1B2	R/W
PHB_CAL_STATUS	16	0x1B4	R/W
PHC_CAL_STATUS	16	0x1B6	R/W

The PHASE_Y CAL_STATUS registers holds the calibration status for each individual phase. Broken down by phase, these are the values that can be calibrated. Each bit has the status of '0' = Not calibrated, '1' = Calibrated.

R/W-0	R/W-0	R/W-0	R/W-0	R/W-0	R/W-0	R/W-0	R/W-0
DELAY	I_RMS_OFF	V_RMS_OFF	I_RMS_GAIN	V_RMS_GAIN	I_RMS_GLSB	V_RMS_GLSB	W_OFF
bit 15							bit 8

R/W-0	R/W-0	R/W-0	R/W-0	R/W-0	R/W-0	U-0	R/W-0
W_GAIN	W_GLSB	VA_GAIN	VA_GLSB	VAR_GAIN	VAR_GLSB	—	STANDARD
bit 7							bit 0

Legend:

R = Readable bit W = Writable bit U = Unimplemented bit, read as '0'
 -n = Value at POR '1' = Bit is set '0' = Bit is cleared x = Bit is unknown

bit 15-2 **CALIBRATION REGISTER:** Calibration register status for offset, gain, LSB, and phase delay

1 = This register has been calibrated
 0 = This register is NOT calibrated

bit 1 **Unimplemented:** Read as '0'

bit 0 **STANDARD:** Standard Phase Bit

1 = Standard Phase is THIS phase
 0 = This phase is NOT the standard phase

3.5.24 STANDARD_W_RAW

REGISTER 3-44: STANDARD_W_RAW REGISTER

Name	Bits	Address	Cof
STANDARD_W_RAW	48	0x1B8	R/W

This calibration register holds the energy value that was accumulated during the standard phase measurement under calibration configuration C1. The software will read this value when performing phase to phase gain matching during active power calibration.

Chapter 4. Meter Protocol and Timings

4.1 PIC18F2520 PROTOCOL

The RS-232 port of the PIC18F2520 is used to access the register map of the meter. In addition to reading and writing of registers, there are also dedicated commands for clearing calibration registers, loading calibration registers, and storing calibration registers to flash. The first byte RS-232 data is an ASCII character that represents the command, and each command has a specific protocol. Each command ends with the ASCII character "X".

4.1.1 Command Description

The first byte of the data (byte 0) is an ASCII character E, L, S, W and R.

- E - Echo All Data Received (ECHO)
- L - Load Calibration Registers from Flash (LOAD)
- S - Store Calibration Registers (STORE)
- W - Write Bytes (WRITE)
- R - Read Bytes (READ)

The last data byte is always an 'X' character. All commands will result in the same command being returned. The exception is the 'R' (read) command which will return additional data in lieu of the number of bytes.

4.1.1.1 "E" ECHO: - ECHO ALL DATA RECEIVED

Example: 'EABCFGHIJKLMNOPQRSTUVWXYZ1234567890X'.

Returns: 'EABCFGHIJKLMNOPQRSTUVWXYZ1234567890X'.

4.1.1.2 "L" LOAD: LOAD CALIBRATION REGISTERS FROM FLASH.

Example: 'LX'.

Returns: 'LX'.

This command is used to verify that the calibration values were actually written into flash (or eeprom). Once the software executes a 'SX' command, it should verify that the values were stored by issuing an 'LX' command and then reading the calibration values with a 'R' command.

4.1.1.3 "S" STORE: STORE CALIBRATION REGISTERS INTO FLASH

Note that the store command will write all calibration values to internal EEPROM and this function takes some time. During that time, the meter is not functional. The store command should only be used after calibrating the meter and not while it is in actual use.

Example: 'SX'.

Returns: 'SX'.

MCP3909 3-Phase Energy Meter Reference Design

4.1.1.4 “W” WRITE: WRITE STARTING AT SPECIFIED ADDRESS

Write specified bytes.

Example: 'W030000102030405060708090A0B0C0D0E0FX'.

Returns: 'W030000102030405060708090A0B0C0D0E0FX'.

Note: If number of data characters is odd, the last character (the one just prior to the 'X') will be ignored.

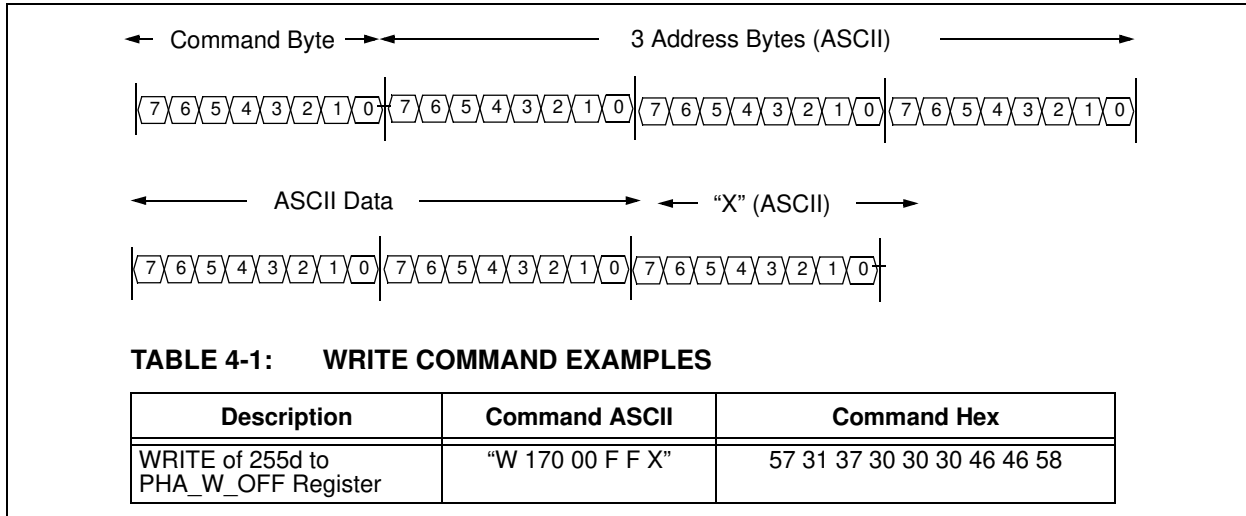

FIGURE 4-1: WRITE Command Protocol.

4.1.1.5 “R” READ: READ STARTING AT SPECIFIED ADDRESS

Example: 'R03010X' (read 16 bytes starting at address 30h).

Returns: 'R030000102030405060708090A0B0C0D0E0FX'.

Note: For 16 bytes, there are 32 ASCII characters returned or two characters per byte.

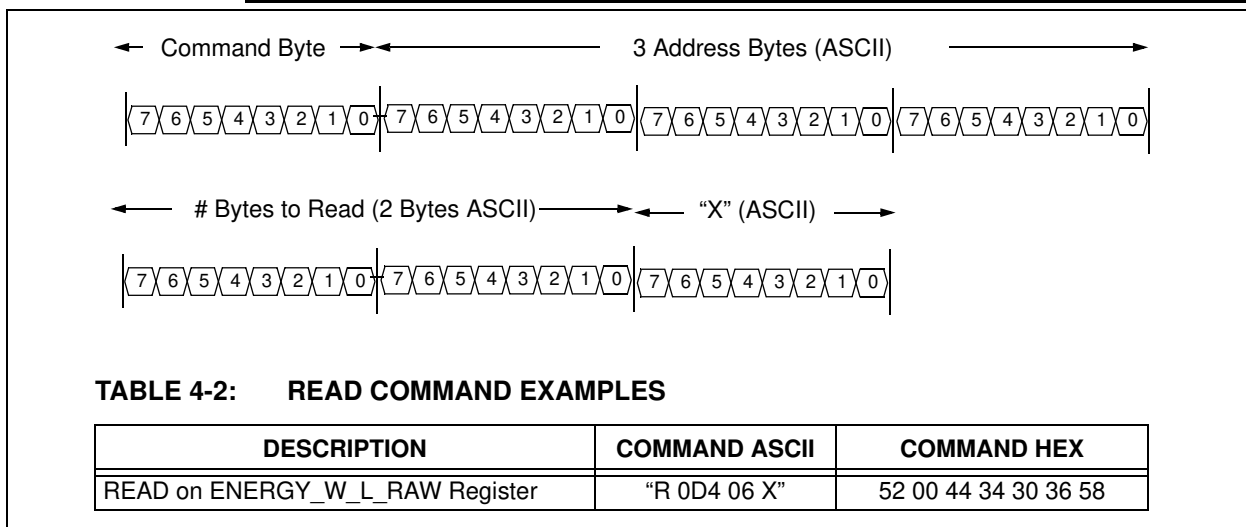

FIGURE 4-2: Read Command Protocol.

Chapter 5. Meter Calibration

5.1 CALIBRATION OVERVIEW

The method to calculate the values for the calibration registers in Chapter 3 are described in this chapter. These registers are used to remove offset, set gain and phase adjustments, and include (units)/LSB adjustments for all the meter outputs. The calibration flow charts and equations presented in this section are all automated using Microchip's "3-phase Energy Meter Calibration Software", downloadable from Microchip's energy metering web site. The following calibration routines are described in this chapter.

- Active Power Calibration
- RMS Current and Voltage Calibration
- Apparent Power Calibration

The method of calibrating these three separate signal flows can be combined into 4 different calibration configurations. These configurations consist of supplying specific voltages and currents at specific phase angles to the meter during calibration.

In addition, one of the 3 phases needs to be set as the "standard" phase for phase matching. This process is described in the following sections through steps and flow charts and is handled automatically by the calibration software described in **Chapter 6. "3-Phase Energy Meter Calibration Software"**.

5.1.1 I_B , V_B , PH<s>, PH<un> Meter Constant and Calibration Configurations

Calibration of the 3-phase power meter involves four different test configurations and three iterations of each of these four configurations, one iteration for each phase. The first iteration is typically done on the "standard" phase. This phase represents the standard that the other two phases must be calibrated to.

For example, meter design example 5(10)A, $I_B = 5$, $I_{MAX} = 10A$.

Calibrating the three phase power meter involves these four test configurations:

1. **Configuration C1** - Basic voltage V_B and basic current I_B at a power factor of 1.
For example, 220V and 5A
2. **Configuration C2** - Basic voltage V_B and basic current I_B at a power factor of 0.5.
3. **Configuration C3** - Basic voltage V_B and 1/100 of I_B at a power factor of 1.
For example, 220V and 50 mA.
4. **Configuration C4** - 1/10 of Basic voltage V_B and 1/10 of I_B at a power factor of 1.
For example, 22V and 1A.

These calibration configurations are typically steps in a sequence. Almost always, configuration C1 is the most important and must be done first. The other configurations require values obtained from configuration C1, but are not dependent on values obtained from the other configurations. In other words, C1 is probably the first step, while the other configurations can be done in any order.

MCP3909 3-Phase Energy Meter Reference Design

Typically, phase A is the standard phase that the other two phases (B and C) are calibrated to. However, there is no particular reason why this should be the case. Still, there needs to be a way of signifying the standard phase. This document uses the shorthand PHy<register name> to stand for an arbitrary register. For example, PHY_W_GAIN stands for PHA_W_GAIN, PHB_W_GAIN, and PHC_W_GAIN.

The notation **PH<s>**... stands for the standard phase register whose value was obtained from the three phase power meter during calibration setup C1. The notation **PH<u1>** represents one of the two uncalibrated phases while **PH<u2>** represents the other. In general, the calibration routines focus on the PH<u1> registers while the PH<u2> registers would be calculated in the same way.

The meter constant is typically given in units of impulses per kilo-watt hour. As an example, the calibration output frequency of CF, METER_CONSTANT = **3200 imp/kWh** or **6400 imp/kWh**.

<p>Note: To calibrate the offset for RMS voltage for a given phase at 1/10 of Vcal, the meter must have power from one of the other two phases.</p>
--

5.2 ACTIVE POWER SIGNAL FLOW AND CALIBRATION

5.2.1 Active Power Calibration Overview & Signal Path

The active power signal flow has two separate signal paths. The first path is a total of all 3 phases and leads to both the CF output pulse frequency, which is proportional to the total active power being measured by the energy meter, and the active energy registers, again, which are functions of all three phases. These energy outputs are in units of kWh and can also be phase gated using the MODE1 register. The second path is unique to each phase and leads to the active power output registers (PHy_W). Each phase has its own separate active power registers.

Table 5-1 represents the registers being set during active power calibration.

TABLE 5-1: CALIBRATION REGISTERS GENERATED THROUGH THIS ROUTINE

Register Name	Equations
CFDEN	Section 5.3.3
CFNUM	Section 5.3.3
PHy_W_GAIN	Section 5.3.5
PHy_DELAY	Section 5.3.7
PHy_W_OFF	Section 5.3.9
PHy_W_GLSB	Section 5.3.3
ENERGY_W_GLSB	Not Implemented

Note: **Important!** There are two important items to consider when calibrating a meter. The first is that each phase must be calibrated separately for the meter to be entirely calibrated. The second item is that since the second signal path includes all 3 phases (CF output and ENERGY), one of the phases must be used to coarsely adjust the calibration registers in this path (CFNUM, CFDEN, and ENERGY_W_GLSB). This phase is the “standard phase”. The other two phases can then be ‘fine tuned’ to gain match the standard phase by adjusting the registers in these paths prior to the three phase summation (PHy_W_GAIN, and PHy_VA_GAIN). These registers **MUST** be set after the coarse registers have been set by one of the three phases.

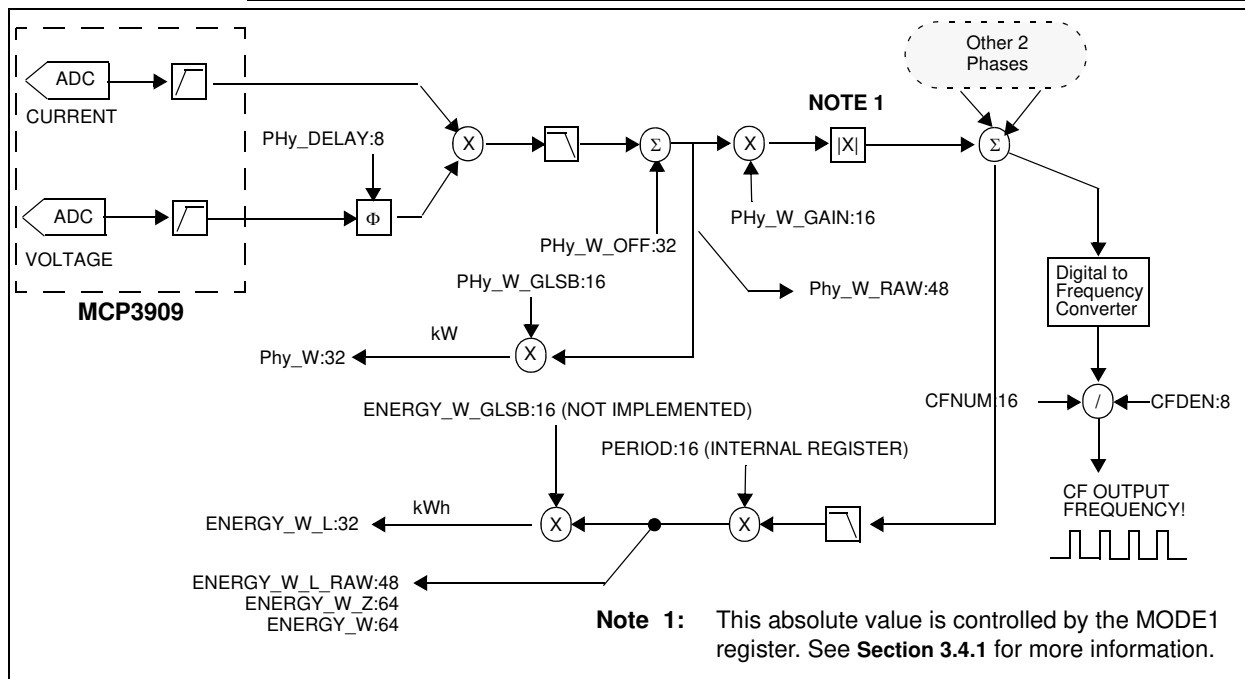

FIGURE 5-1: Active Power Signal Path showing Output and Calibration Registers.

MCP3909 3-Phase Energy Meter Reference Design

5.3 RMS CURRENT, RMS VOLTAGE, APPARENT POWER SIGNAL FLOW AND CALIBRATION

5.3.1 RMS Current, RMS Voltage, and Apparent Power Overview and Signal Path

The RMS current and voltage outputs require a two point calibration reading at configurations C1 and C4. The automated USB software performs these calibrations suggested on the calibration values entered in the text boxes on the meter design window.

The following table represents the registers being set for RMS Current and Voltage calibration.

TABLE 5-2: RMS CURRENT, RMS VOLTAGE, AND APPARENT POWER CALIBRATION REGISTERS

Register	Equation
Phy_V_RMS_OFF	Section 5.3.11
Phy_I_RMS_OFF	Section 5.3.11
Phy_V_RMS_GLSB	Section 5.3.11
Phy_I_RMS_GLSB	Section 5.3.11
Phy_VA_GAIN	Section 5.3.5
Phy_VA_GLSB	Section 5.3.3
ENERGY_VA_GLSB	Not Implemented

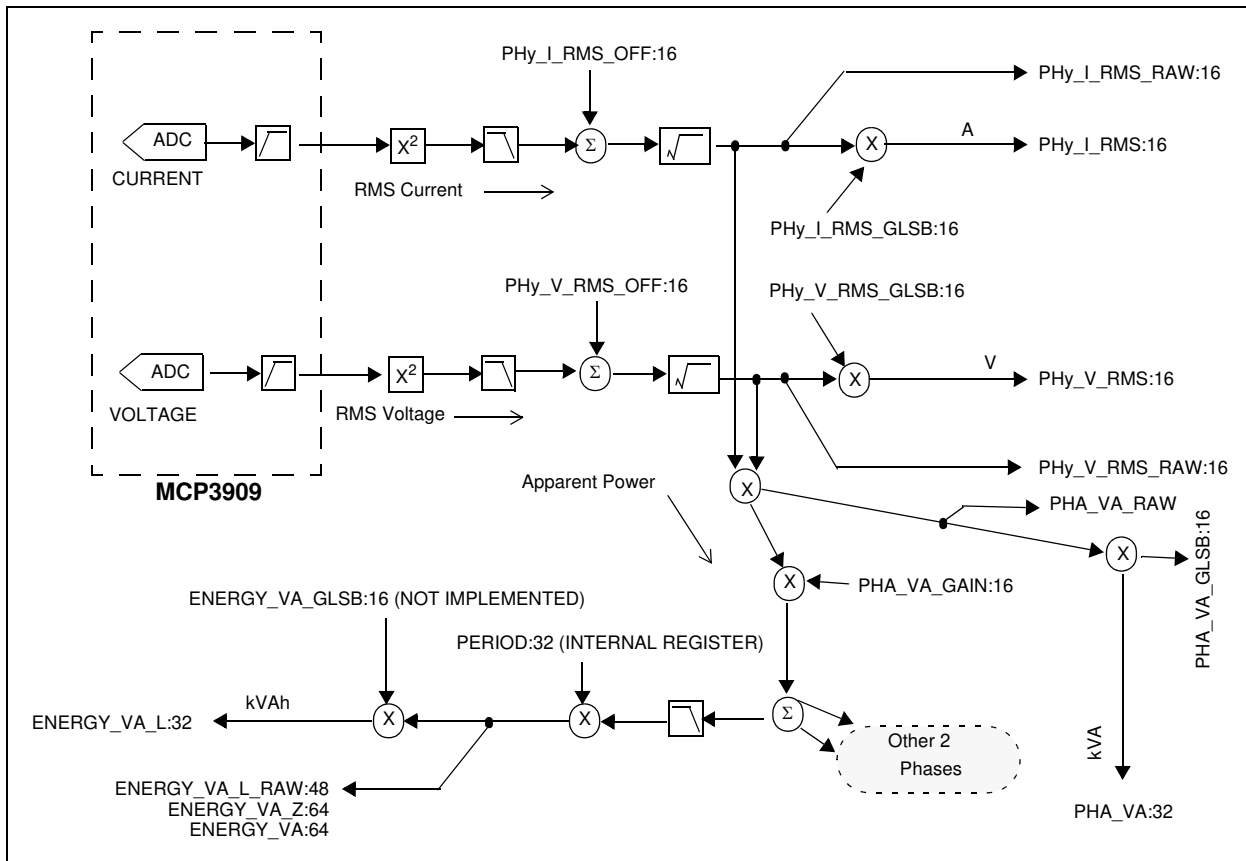

FIGURE 5-2: RMS Current, Voltage, and Apparent Power Flow.

5.3.2 Main Flow Chart for Calibration

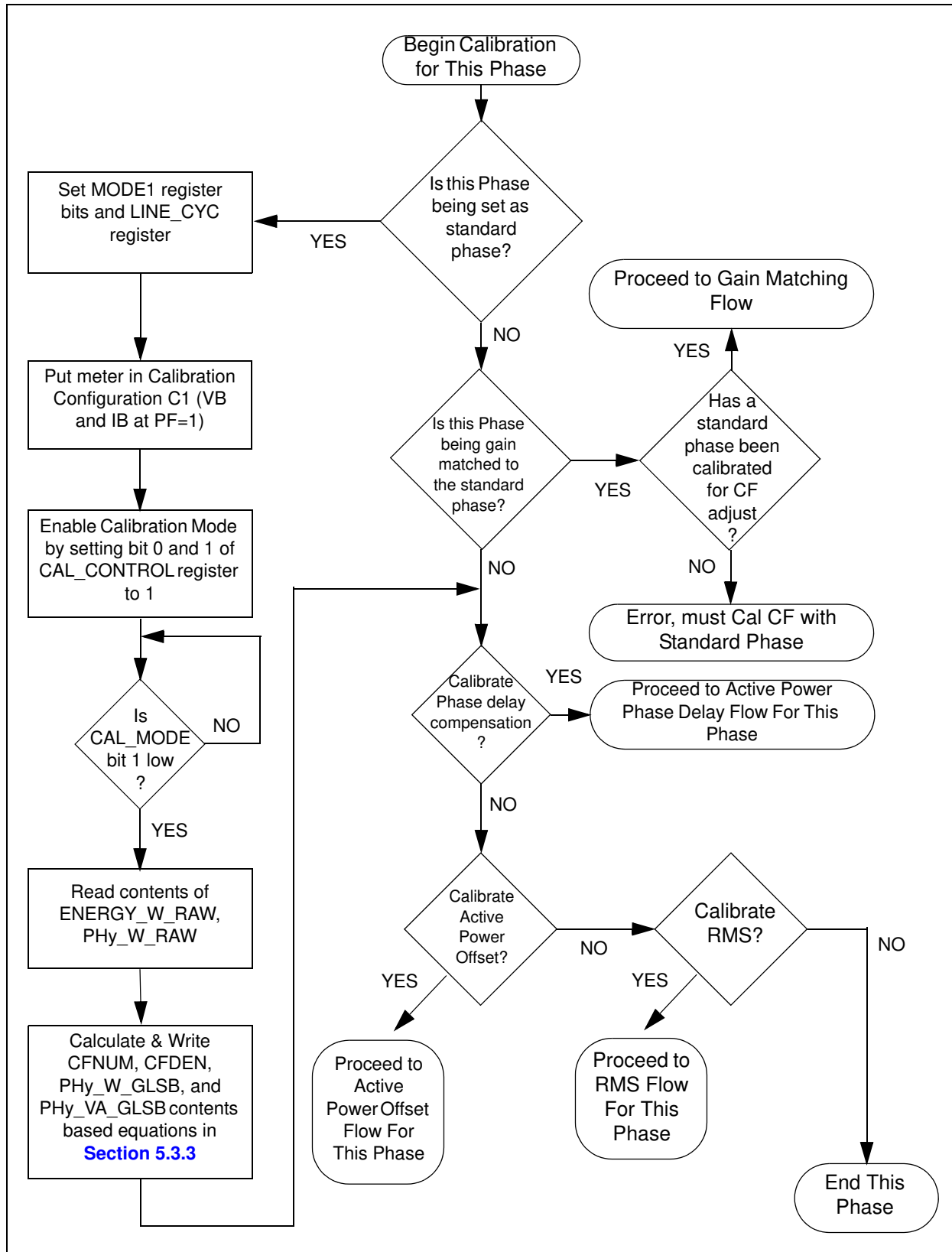

FIGURE 5-3: Main Calibration Flow Chart.

MCP3909 3-Phase Energy Meter Reference Design

5.3.3 Equations for Configuration C1 Calibration

The following equations represent the proper method for calculating the calibration and correction factors after configuration C1. The PC calibration software handles these calculations automatically.

The following equations only apply when calibrating a standard phase.

The first 4 equations apply for calculating the proper output frequency of the CF output. See Figure 5-3 for meter input conditions.

EQUATION 5-1:

$$CF_IMP_S = \frac{\text{Meter Constant}}{3600} \cdot \frac{V_B I_B}{1000}$$

EQUATION 5-2:

$$LINE_CYC_NUM = 2^{LINE_CYC}$$

EQUATION 5-3:

$$CFDEN = \frac{\text{LOG} \left[\frac{2^{32} \cdot CF_IMP_S}{\text{Line Freq} \cdot 128} \right] \left[\frac{LINE_CYC_NUM \cdot 256}{ENERGY_W_L_RAW} \right]}{\text{LOG}(2)} + 1$$

Note: Convert to 8-bit signed integer for compatibility with 18F2520 register and firmware calculations.

EQUATION 5-4:

$$CFNUM = \frac{\left(\frac{2^{32} \cdot CF_IMP_S}{\text{Line Freq} \cdot 128} \right)}{\left(\frac{ENERGY_W_L_RAW}{LINE_CYC_NUM \cdot 256} \right)} \cdot 2^{CFDEN} \cdot 32768$$

Note: Convert to 16-bit signed integer for compatibility with 18F2520 register and firmware calculations.

The gain matching registers for the standard phase need to be set to the following values when calibrating a standard phase:

EQUATION 5-5:

$$PHY_W_GAIN = 16,384$$

The following equations apply for calculating the proper GLSB registers when calibrating both a standard phase, and a non-standard phase. See flow chart for meter input conditions.

EQUATION 5-6:
$$PLSB = \text{Value from Table 6-3 based on } V_B \text{ and } I_{MAX} \text{ values}$$
EQUATION 5-7:

$$PHY_W_GLSB = \frac{\left(\frac{V_B \cdot I_B}{PLSB}\right)}{\left(\frac{PHY_W_RAW}{64 \cdot LINE_CYC_NUM}\right)} \cdot 32768$$

Note: Convert to 16-bit signed integer for compatibility with 18F2520 register and firmware calculations.

The calculation for PHY_VA_GLSB is identical except that it uses the PHY_VA_RAW register instead of PHY_W_RAW:

EQUATION 5-8:

$$PHY_VA_GLSB = \frac{\left(\frac{V_B \cdot I_B}{PLSB}\right)}{\left(\frac{PHY_VA_RAW}{64 \cdot LINE_CYC_NUM}\right)} \cdot 32768$$

Note: Convert to 16-bit signed integer for compatibility with 18F2520 register and firmware calculations.

MCP3909 3-Phase Energy Meter Reference Design

5.3.4 Flow Chart for Gain Matching Flow

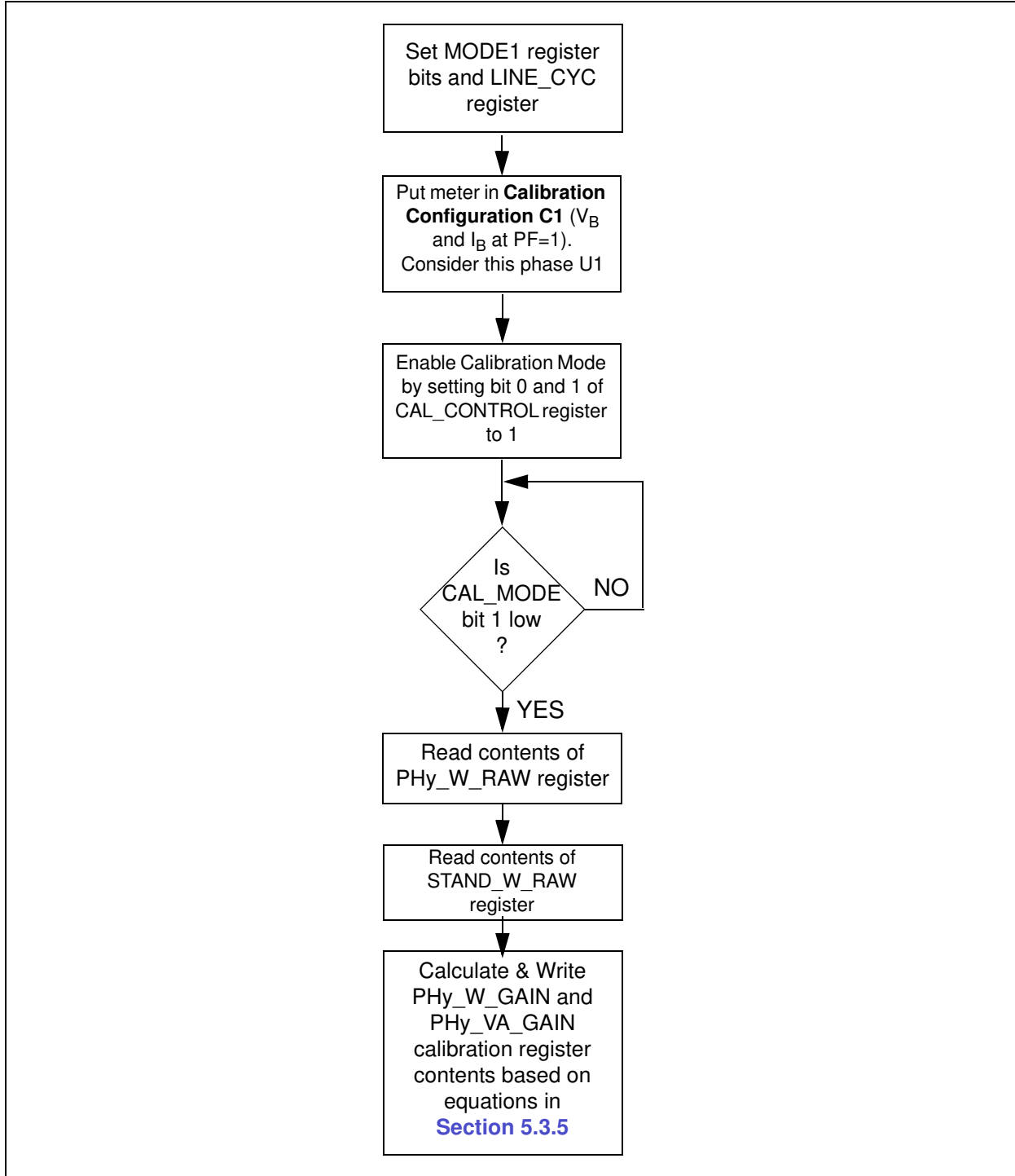

FIGURE 5-4: Gain Matching Flow Chart.

5.3.5 Gain Matching Equations

The following equations apply for calculating the gain matching in between phases.

The notation “<S>” is used for the standard phase measurement, thus the PH<S>_W_RAW number is read from the standard phase register, STAND_W_RAW, that was recorded during the standard phase calibration.

The notation “<Un>” represents the value for the phase being matched to the standard phase.

For active power gain matching:

EQUATION 5-9:

$$PHY_W_GAIN = \left(\frac{STAND_W_RAW}{PHY_W_RAW} \right) \bullet 16384$$

Note: Convert to 16-bit signed integer for compatibility with 18F2520 register and firmware calculations.

For apparent power gain matching:

EQUATION 5-10:

$$PHY_VA_GAIN = \left(\frac{STAND_W_RAW}{PHY_VA_RAW} \right) \bullet 16384$$

Note: Convert to 16-bit signed integer for compatibility with 18F2520 register and firmware calculations.

MCP3909 3-Phase Energy Meter Reference Design

5.3.6 Flow Chart for Active Power Phase Delay

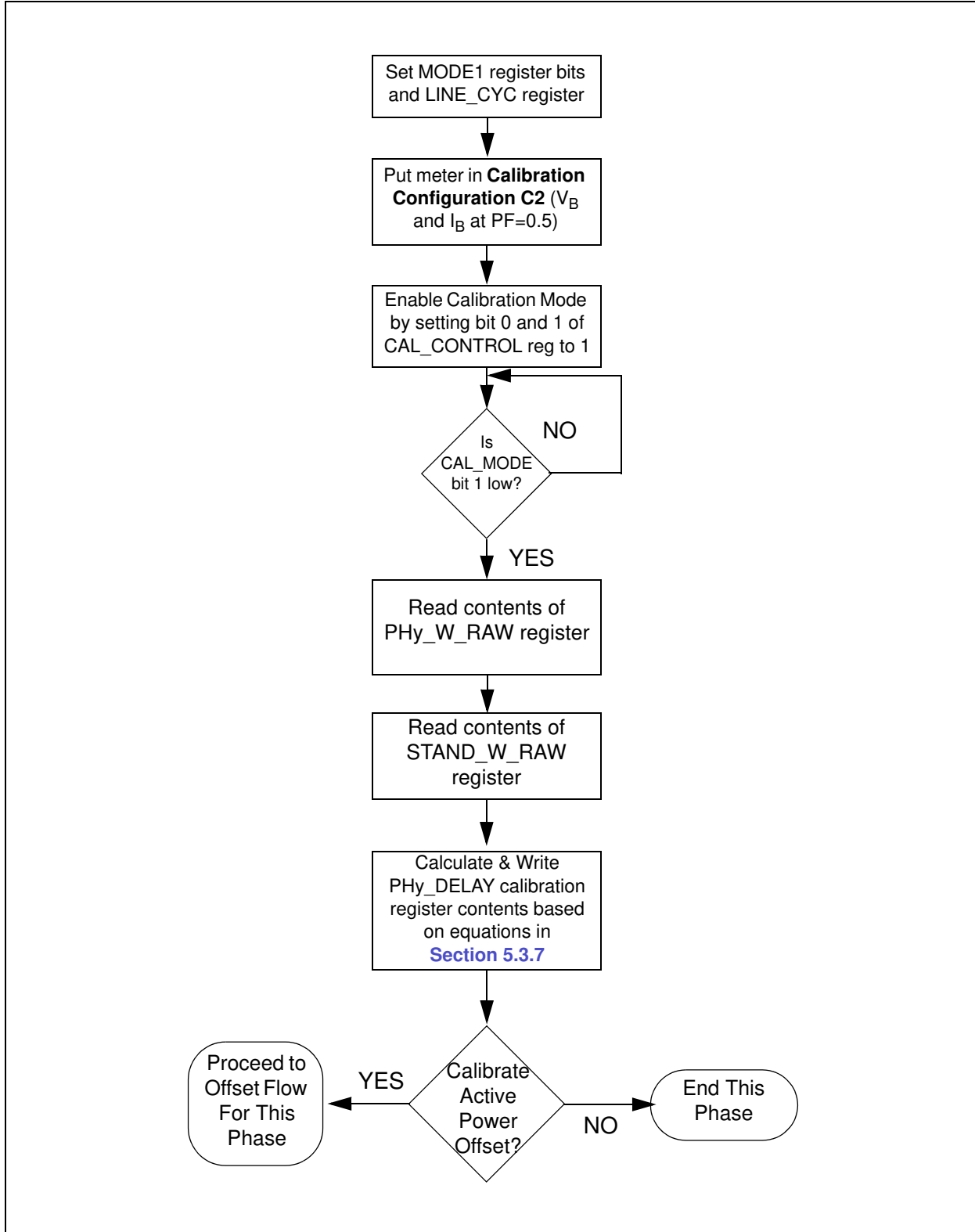

FIGURE 5-5: Active Power Phase Delay Flow Chart.

5.3.7 Phase Matching Equations

For active power the following equations apply for calculating the time shift delay for a given phase.

EQUATION 5-11:

$$W1 = PHY_W_RAW @ PF = 1, \text{ Configuration C1}$$

EQUATION 5-12:

$$W2 = PHY_W_RAW @ PF = 0.5, \text{ Configuration C2}$$

EQUATION 5-13:

$$LINE_CYC_NUM_1 = LINE_CYC_NUM @ PF = 1, \text{ Configuration C1}$$

EQUATION 5-14:

$$LINE_CYC_NUM_2 = LINE_CYC_NUM @ PF = 0.5, \text{ Configuration C2}$$

EQUATION 5-15:

$$PHY_DELAY = \frac{\left[\cos^{-1} \left(\frac{W2 / LINE_CYC_NUM2}{W1 / LINE_CYC_NUM1} \right) \times \frac{180}{PI} \right] - 60}{2.8125} \bullet 128$$

Note 1: Convert to 8-bit signed integer for compatibility with 18F2520 register and firmware calculations.

2: Since 60 degrees (default) is being subtracted from the measured quantity, the current should lag the voltage under configuration C2.

MCP3909 3-Phase Energy Meter Reference Design

5.3.8 Flow Chart for Active Power Offset

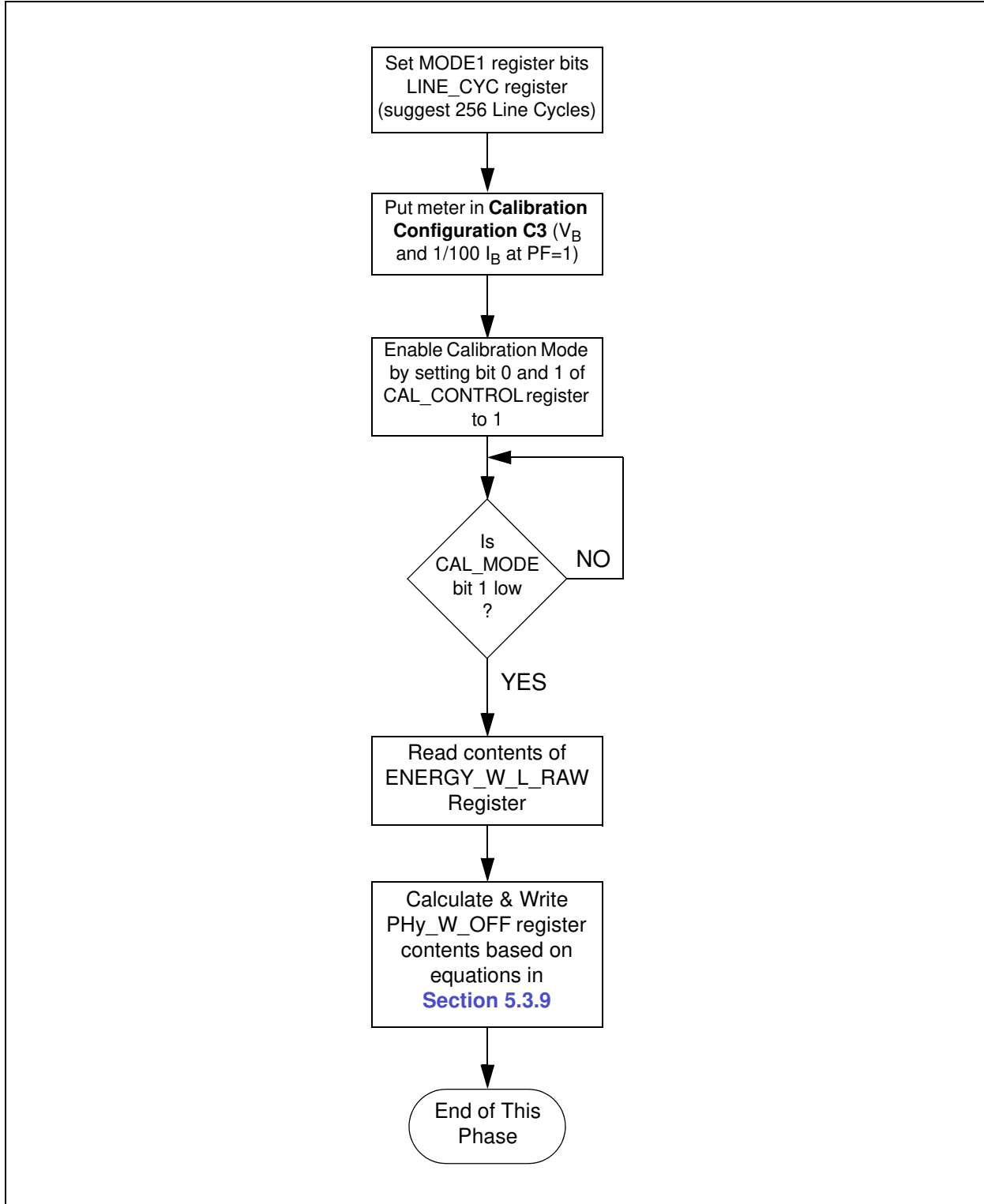

FIGURE 5-6: Active Power Offset Flow Chart.

5.3.9 Equations for Active Power Offset Calibration

For active power offset the following equations apply for a given phase. W1 corresponds to the PHY_W_RAW register obtained during configuration C1. LINE_CYC_W1 corresponds to the LINE_CYC during this measurement.

W2 corresponds to the PHY_W_RAW register obtained during configuration C3. LINE_CYC_W2 is the LINE_CYC during this measurement.

EQUATION 5-16:

$$W1 = PHY_W_RAW @ I_B, Configuration C1$$

EQUATION 5-17:

$$W2 = PHY_W_RAW @ 1/100 I_B, Configuration C3$$

EQUATION 5-18:

$$LINE_CYC_NUM_1 = LINE_CYC_NUM in Configuration C1$$

EQUATION 5-19:

$$LINE_CYC_NUM_2 = LINE_CYC_NUM in Configuration C3$$

EQUATION 5-20:

$$PHY_W_OFF = \left[\frac{W1/100}{LINE_CYC_NUM_W1} \right] - \left[\frac{W2}{LINE_CYC_NUM_W2} \right]$$

Note: Convert to 32-bit signed integer for compatibility with 18F2520 register and firmware calculations

The PHY_W_OFF registers hold a signed 32-bit value. However, the math in the microcontroller could overflow for some values near the limits. Limit check the resulting value to make sure the value is between -2,130,706,432 and 2,130,706,431 (inclusive). Values less than -2,130,706,432 should be set to -2,130,706,432 while values greater than 2,130,706,431 should be set to 2,130,706,431. If the value is limited, the user should be aware that the meter could not completely correct the offset.

It is expected that this value will always be negative. If the value is positive, it may indicate that the user has not provided a large enough number of line cycles for configuration C4 (where the number of line cycles should be set to a larger value such as 64 or 128). This may also be true if offset does not contribute a large enough percentage to W2 (for example, 10% to 50% or more).

MCP3909 3-Phase Energy Meter Reference Design

5.3.10 Flow Chart for RMS Calibration

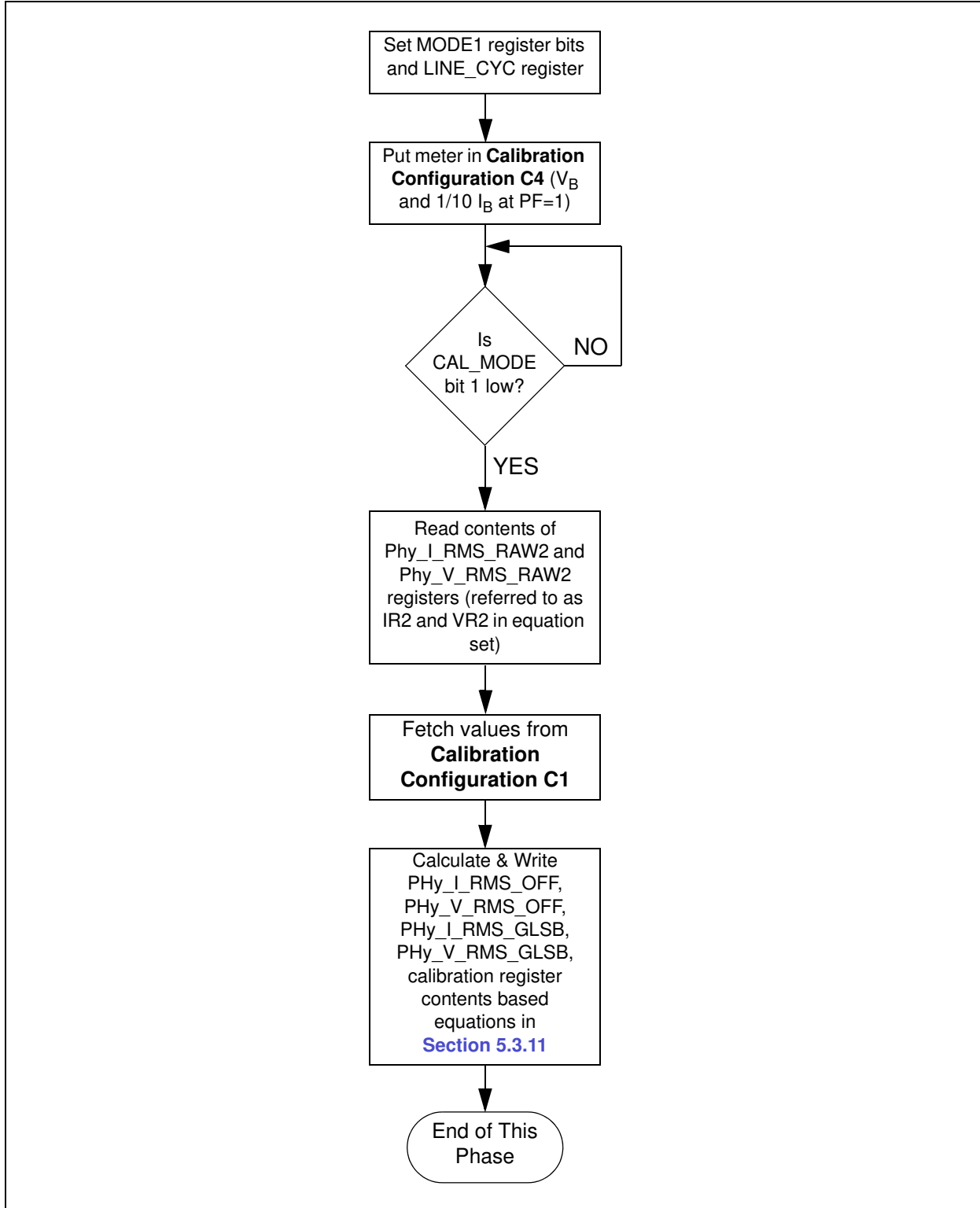

FIGURE 5-7: Flow Chart for RMS Calibration.

5.3.11 Equations for RMS Calibration

The following equations represent the proper method for calculating the calibration and correction factors for the RMS current and RMS voltage. The PC calibration software handles these calculations automatically.

Typically, the V_{MIN} and I_{MIN} voltages and currents will be 1/10 of the V_B and I_B values. For RMS Offset the following equations apply:

EQUATION 5-21:

$$IR1 = PHY_I_RMS_RAW2 @ I_B, \text{ Configuration C1}$$

EQUATION 5-22:

$$VR1 = PHY_V_RMS_RAW2 @ I_B, \text{ Configuration C1}$$

EQUATION 5-23:

$$IR2 = PHY_I_RMS_RAW2 @ I_B, \text{ Configuration C4}$$

EQUATION 5-24:

$$VR2 = PHY_V_RMS_RAW2 @ I_B, \text{ Configuration C4}$$

EQUATION 5-25:

$$I_G = \frac{I_B @ C1}{I_B @ C4}$$

EQUATION 5-26:

$$V_G = \frac{V_B @ C1}{V_B @ C4}$$

EQUATION 5-27:

$$PHY_I_RMS_OFF = \frac{\left(\frac{IR1 - IR2}{IG \bullet IG - 1}\right) - IR2}{65536}$$

Note: Convert to 16-bit signed integer for compatibility with 18F2520 register and firmware calculations

MCP3909 3-Phase Energy Meter Reference Design

EQUATION 5-28:

$$PHY_V_RMS_OFF = \frac{\left(\frac{VR1 - VR2}{VG \bullet VG - 1}\right) - VR_2}{65536}$$

Note: Convert to 16-bit signed integer for compatibility with 18F2520 register and firmware calculations

For RMS LSB correction, the following equations apply:

EQUATION 5-29:

$$ILSB = \text{Value from Table 6-2 based on } I_{MAX} \text{ value}$$

EQUATION 5-30:

$$VLSB = \text{Value from Table 6-4 based on } V_B \text{ value}$$

EQUATION 5-31:

$$PHY_I_RMS_GLSB = \frac{\left(\frac{I_B}{ILSB}\right)}{\sqrt{\frac{IR_1}{65536} + PHY_I_RMS_OFF}} \bullet 32768$$

Note: Convert to 16-bit signed integer for compatibility with 18F2520 register and firmware calculations

EQUATION 5-32:

$$PHY_V_RMS_GLSB = \frac{\left(\frac{V_B}{VLSB}\right)}{\sqrt{\frac{VR_1}{65536} + PHY_V_RMS_OFF}} \bullet 32768$$

Note: Convert to 16-bit signed integer for compatibility with 18F2520 register and firmware calculations

Chapter 6. 3-Phase Energy Meter Calibration Software

6.1 OVERVIEW

This chapter is meant to serve as a user’s guide for Microchip’s energy meter calibration software “3-Phase Energy Meter Calibration Software”. The software is compatible with Windows® XP and Windows® 2000. The software uses USB to communicate to the energy meter, however, the commands are converted to RS-232 commands which are carried out on the PIC18F2520. The USB interface is solely for the calibration software and meter connection.

6.2 USING THE CALIBRATION SOFTWARE WITH THE USB INTERFACE MODULE

To use the monitoring and calibration software on the PC you must have the USB Interface Module installed on the main board of the MCP3909 3-Phase Energy Meter Reference Design, OR have a customized meter and USB to RS-232 interface located off the meter. This board does not have to be in the final meter design for RS-232 low-cost meters.

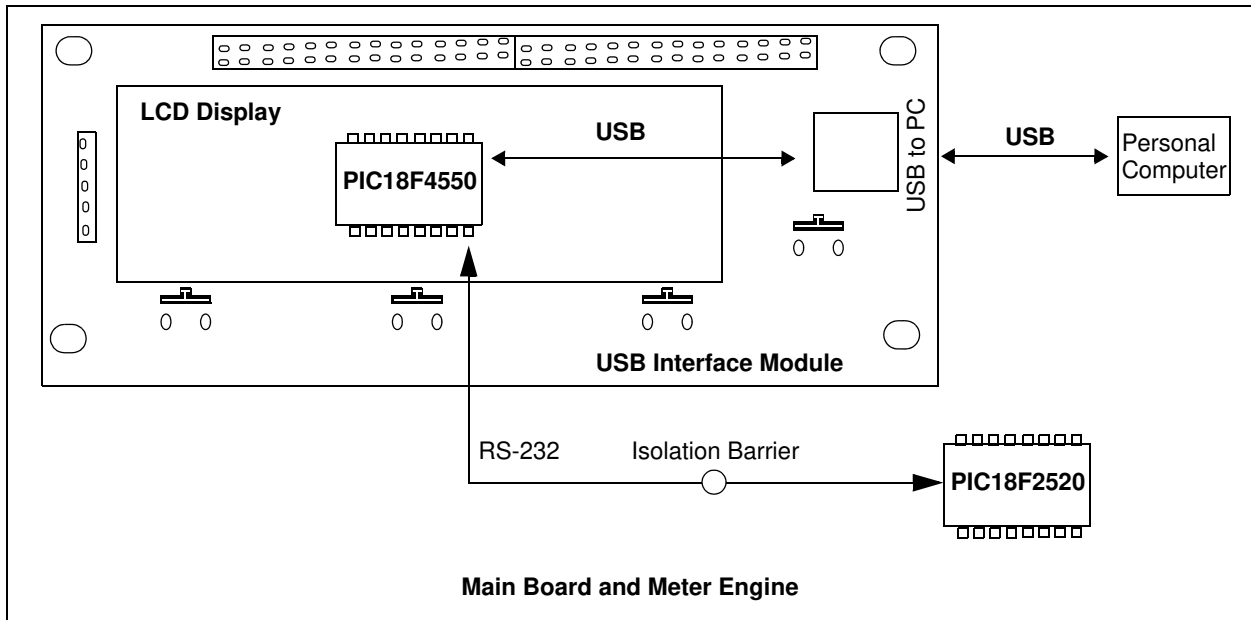

FIGURE 6-1: *USB to RS-232 Communication.*

The PIC18F4550 is set up as a full speed HID device (Host Interface Device). The USB communication uses 64 byte reports. The full 64-byte report is 64 8-bit bytes with values from 0x00 to 0xFF. The USB report structure will be the same as the RS-232 command structure from the PIC18F4550 to the PIC18F2520. This will allow a RS-232 version of the software to be easily written. The PIC18F4550 simply shifts these commands from the USB port out the RS-232 port to the PIC18F2520.

MCP3909 3-Phase Energy Meter Reference Design

6.3 SOFTWARE OVERVIEW AND TAB CONTROL

The software has three tabs at the top that correspond to three different frames in the main screen.

- Results
- Log
- Communications

The results frame shows the power readings coming back from the meter, such as active power, apparent power, RMS current and RMS voltage.

The log frame shows the message logs that are used to record all activity that is taking place inside the software during calibration, reading, writing registers, etc.

The communications frame shows all USB activity that takes place during calibration or meter reading. This can be used to track activity and generate customized meter calibration scripts.

Note that at software start, the program polls to see if the meter is connected to the PC via USB. If the meter hardware is found connected (or not connected), an appropriate message is placed in the scrolling message/status window, e.g. "Meter not connected (PID0x0xx)", and the icon in the bottom right hand corner of the results window is turned red. When a meter is connected, the icon is green and the software refreshes all visible registers and calibration icons.

3-Phase Energy Meter Calibration Software

6.4 RESULTS FRAME

This frame shows the present readings coming back from the meter, contains buttons for calibration control, contains a frame for all the registers in the PIC18F2520, and contains a frame to input the meter design constants such as calibration current, maximum current, meter constant, and others.

	PHASE A	PHASE B	PHASE C	TOTAL
Active Power (W)	102.88	0	0	102.88
Apparent Power (KVA)	101.4498	0.0027	0	101.4525
RMS Current (A)	0.45	0.01	0	0.46
RMS Voltage (V)	220.2	0.6	0	220.8

Address	Name	Bits	R/W	Value (POR Shown)	Description	Monitor ?
0x000	MODE1	16	R/W	0x0A	Operating mode	0
0x002	Reserved	16	--	0x00	Reserved (possibly MODE2 register).	0
0x004	STATUS1	16	R	0x00	Status information	0
0x006	Reserved	16	--	0x00	Reserved (possibly STATUS2 register).	0
0x008	CAL_CONTROL	16	R/W	0x00	Calibration control register	0
0x00A	LINE_CYC	16	R/W	0x07	Number of line cycles as a power of two.	0
0x00C	LINE_CYC_CNT	16	R	0x00	Number of line cycles so far.	0
0x00E	Reserved	16	--	0x00	Reserved.	0
0x010	PHA_I_RMS_RAW2	48	R	0x4E1D4058	This is the square of the raw values of phase A current.	0
0x016	PHA_I_RMS_RAW	16	R	0x58E	This is the raw RMS value of phase A current.	0
0x018	PHA_I_RMS	16	R	0x7D	This is the RMS value of phase A current.	0

FIGURE 6-2: Main Screen with Results Frame Active.

The results frame contains the current power and energy measurement results from the three phases. The registers in this frame are continually polled from the USB device and refreshed on the PC side every 2.5 seconds.

The following registers represent the results that are ready from the meter in this area of the software. The text boxes in the results frame that are totals, are the sum of the three phases. This total is done on the software side, all other numbers in this frame are the exact number that is read from the registers in Table 6-1.

TABLE 6-1: REGISTERS BEING READ FOR THE METER READING (NOTE 1)

Meter Reading	Register	Example
Active Power, Phase A	PHA_W	102.88 W
Active Power, Phase B	PHB_W	104.22 W
Active Power, Phase C	PHC_W	103.77 W
Apparent Power, Phase A	PHA_VA	273.2371 VA

Note 1: At the time of this software and document release, reactive power and reactive energy is not supported. Contact Microchip for updated software and firmware that will be available for these power quantities.

MCP3909 3-Phase Energy Meter Reference Design

TABLE 6-1: REGISTERS BEING READ FOR THE METER READING (NOTE 1)

Meter Reading	Register	Example
Apparent Power, Phase B	PHB_VA	266.2323 VA
Apparent Power, Phase C	PHC_VA	208.11 VA
RMS Current Phase A	PHA_I_RMS	0.45 A
RMS Current Phase B	PHB_I_RMS	0.33 A
RMS Current Phase C	PHC_I_RMS	10.23 A
RMS Voltage Phase A	PHA_V_RMS	220.1 V
RMS Voltage Phase B	PHB_V_RMS	222.4 V
RMS Voltage Phase C	PHC_V_RMS	220.9 V

Note 1: At the time of this software and document release, reactive power and reactive energy is not supported. Contact Microchip for updated software and firmware that will be available for these power quantities.

6.4.1 Decimal Point Location

The location of the decimal point, i.e the resolution of the power quantities, is determined by the values that are entered in the meter design section of this screen. When the meter is calibrated using the calibration steps automated with this software, the proper GLSB correction factor is calculated to ensure the least significant bit represents the least significant digit for a given quantity. For example, if the PHA_I_RMS register, which represents the RMS current for Phase A, contains the decimal value 4523 and the ILSB has been defined to be 0.01 based on the meter design entry, this value represents *exactly* 45.23 Amperes.

Another example for active power as shown in Figure 6-2, the PHA_W register contains the value 1014498. For this meter design example the power resolution was defined to be 0.1 mW. Therefore this register represents *exactly* 101.4498 Watts.

3-Phase Energy Meter Calibration Software

6.5 CALIBRATION ICONS

The results frame contains small symbols that represent if a given calibration STEP has occurred, and a given calibration register has been written, or not.

	PHASE A	
Active Power (W)	CF	
	ϕ	
	O	102.88
	G	
Apparent Power (KVA)	L	
	G	101.4498
RMS Current (A)	L	
	O	0.45
RMS Voltage (V)	L	
	O	220.2

There are 5 symbols for total that represent the steps of calibration.

- CF for standard phase calibration
- ϕ - Phase delay
- O - Offset
- G - Gain
- L - GLSB

The status of these symbols (enabled / disabled) are saved in the PH_Y_CAL_STATUS registers and is loaded when the software detects a meter connected to the PC. A yellow icon represents that a given step HAS OCCURED.

It should be noted that the CF icon can only be enabled in 1 of the 3 phases. This is because only 1 phase can be selected as the 'standard phase', and the other phases must then be gained matched to this standard phase. For this reason you will note that the gain icons for active power and apparent power 'G' are disabled in the standard phase by turning a dark grey color.

For more information on the various steps of calibration, refer to **Chapter 5. "Meter Calibration"**.

6.6 REGISTER LIST

The results screen also includes a complete list of the registers, their address, name, width, state (readable (R) or readable and writable (R/W)), value, description, and if they have been selected for monitor refresh.

Unless they have been selected to be monitored, the registers in this frame are NOT updated every 2.5 seconds like the meter reading section. To refresh the complete register list, select "**Refresh**" from the menu.

To select a specific register for monitor, right click on the row in this frame and then select "**monitor**" from the menu by left-clicking.

6.7 WRITING TO INDIVIDUAL REGISTERS

While not recommended as it will interfere with the calibration process, it is possible to write to individual registers. All writes to registers is automated during the calibration process, and it should not be necessary to write to a specific register to calibrate a meter. However you can perform writes to your meter and test various configurations by writing to the registers individually.

To write a value to a specific register, right click on the register and then select "**write value**" on the menu by left clicking. At this point, you will be asked the value to be written to the meter.

MCP3909 3-Phase Energy Meter Reference Design

6.8 METER CALIBRATION

One of the main functions of the software is to assist in meter calibration. This process is accomplished by selecting the phase for calibration and clicking the “**CALIBRATE**” button. The following steps will occur for a given phase:

1. Calibrate phase under configuration C1 as either a standard phase or a non-standard phase.
2. Calibrate phase under configuration C2 for phase delay.
3. Calibrate phase under configuration C3 for active power offset.
4. Calibrate phase under configuration C4 for RMS offset.

For a meter to be entirely calibrated, all 3 phases must be calibrated separately, with one of the phases being selected as the standard phase.

6.8.1 Calibration Step 1 - Configuration C1

The first step is to apply VCAL and ICAL to a given phase and choose whether or not this phase is being selected as the standard phase. The software will prompt the user with this question and also instruct the user to apply the correct voltages and currents.

The software calculates the calibration registers through the equations defined in **Chapter 5. “Meter Calibration”** and allows the user to input the exact voltages and current for more correct calibration register numbers.

The following dialog window will appear in configuration C1:

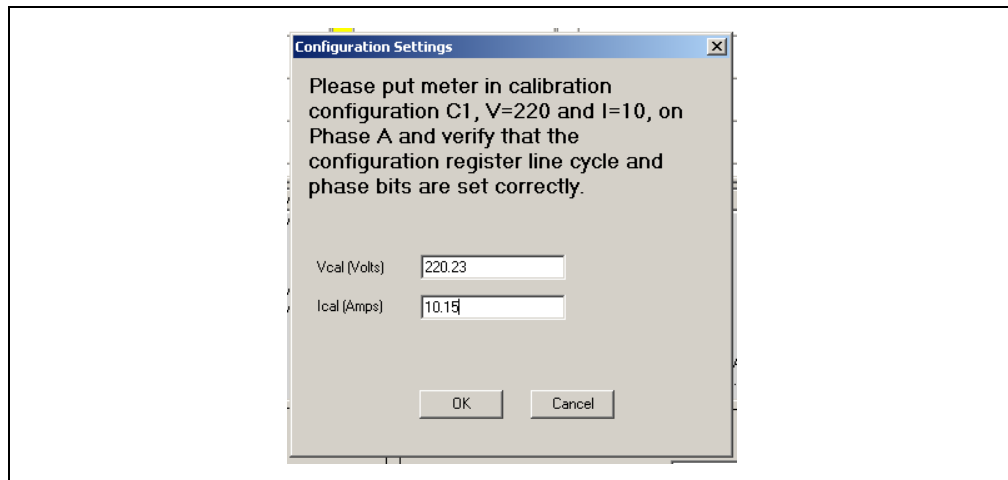

FIGURE 6-3: Calibration Step C1 with calibration settings input boxes.

At this point, the software will default to the VCAL and ICAL values that are currently in the meter design frame. The user can MODIFY these values to the exact currents and voltages that are being read from the calibrated meter equipment present during calibration. In the example above, the user modified the numbers 220 to be 220.23V and 10A to be 10.15A.

Once the user selects the “**OK**” button, energy accumulation will occur and status can be observed via the energy accumulation bar.

Section 5.3.3 and **Section 5.3.5** describes the registers and equations that the software uses to calibrate the meter.

3-Phase Energy Meter Calibration Software

6.8.2 Calibration Step 2 - Configuration C2

The next step will be to calibrate the PHASE ANGLE correction, if desired. The software will prompt the user if this calibration step is necessary. Then the following dialog box will be given.

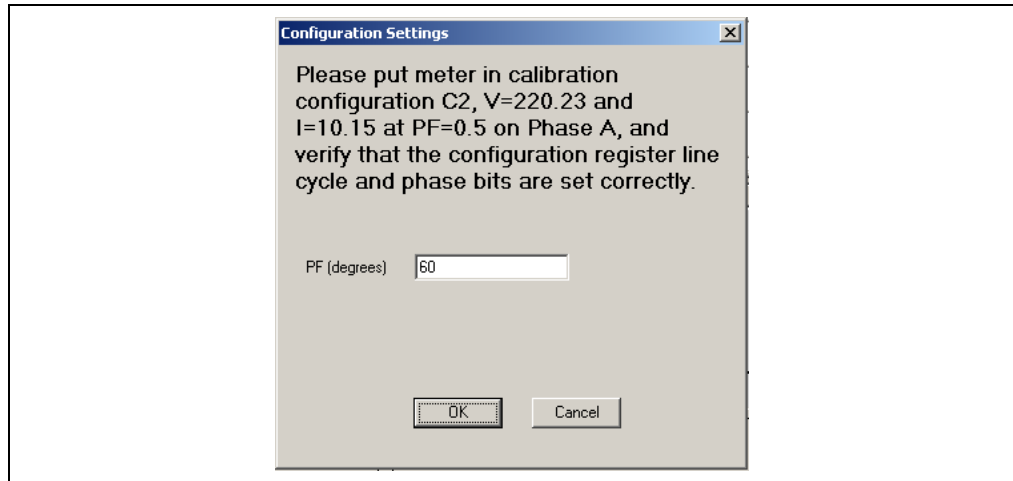

FIGURE 6-4: Calibration Step C2 with calibration settings input boxes.

At this point, the software will default to the value of 60 degrees for the phase delay. The user can MODIFY these values to the exact phase delay based on calibrated equipment readings.

Note that the dialog box uses the values for VCAL AND ICAL that were given during configuration C1. This is because the user is expected to not change the currents and voltages during this step, only the phase angle. If the voltages and currents change between steps 1 and 2, the calibration will not be accurate.

Once the user selects the “OK” button, energy accumulation will occur and status can be observed via the energy accumulation bar.

Section 5.3.7 describes the registers and equations that the software uses at this point to calibrate the phase angle correction of the meter and PHY_DELAY register for the appropriate phase.

Note: IMPORTANT! The equations that are hard-coded into the software subtract 60 degrees *from* the measured quantity. For this reason, it is expected that the current *lag* the voltage during this calibration step.

MCP3909 3-Phase Energy Meter Reference Design

6.8.3 Calibration Step 3 - Configuration C3

The next step will be to calibrate the active power offset of the meter, if desired. The default value for this calibration step is 1% of the ICAL current that was used for steps 1 and 2. The user can enter the exact value in the dialog box for more accurate meter calibration.

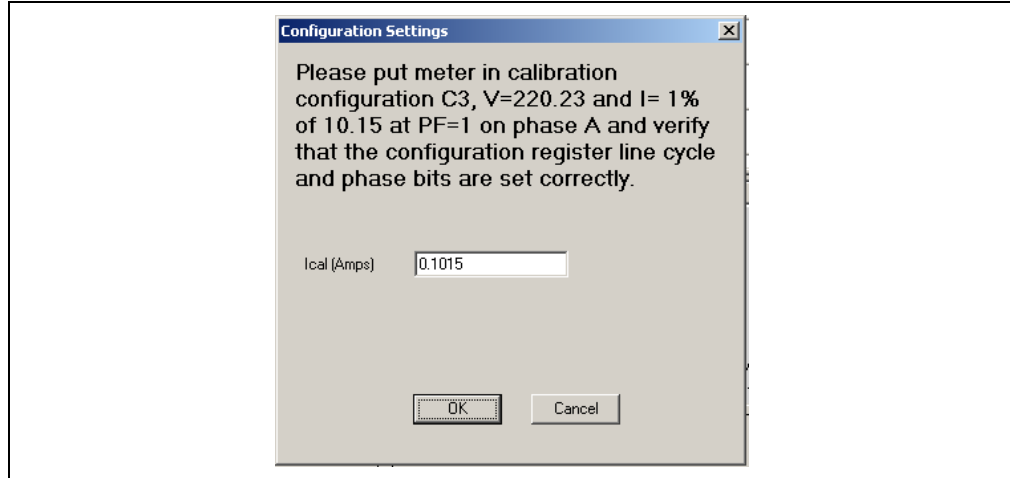

FIGURE 6-5: Calibration Step C3 with calibration settings input boxes for the minimum current for active power offset calibration (in Amperes).

Section 5.3.9 describes the registers and equations that the software uses at this point to calibrate the active power offset correction of the meter and PHY_OFF register for the appropriate phase.

3-Phase Energy Meter Calibration Software

6.8.4 Calibration Step 4 - Configuration C4

The final calibration step will be to calibrate the RMS current offset of the meter, if desired. The default value for this calibration step is 10% of the ICAL current that was used for steps 1 and 2. The user can enter the exact value at this point in the dialog box for more accurate meter calibration.

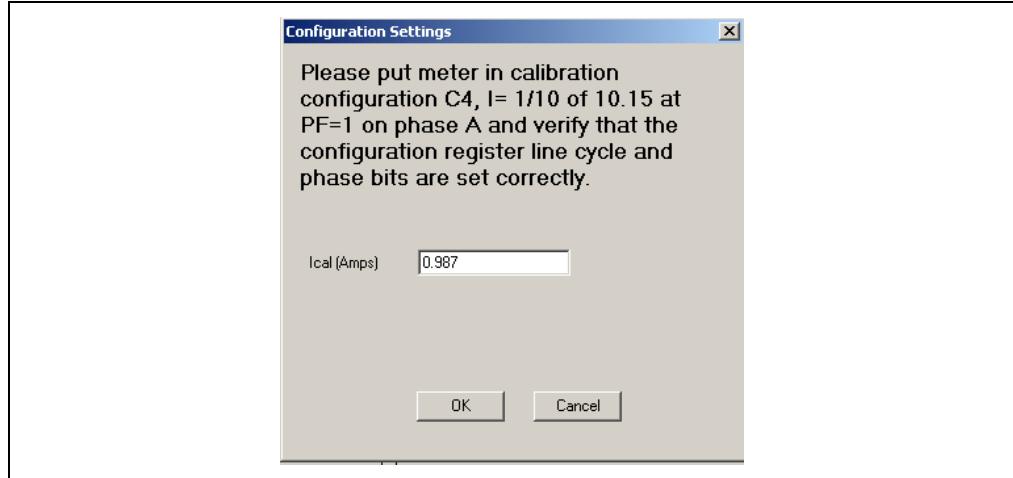

FIGURE 6-6: Calibration Step C4 with calibration settings input boxes for the minimum current for active power offset calibration (in Amperes).

Section 5.3.11 describes the registers and equations that the software uses at this point to calibrate the RMS offset correction of the meter for the appropriate phase. Note that the software does not calculate the RMS voltage offset.

After the completion of step 4, the software will prompt you to save the calibration registers to EEPROM.

Calibration of this phase is now complete.

6.8.5 Calibration Line Cycle Selection Pull Down

The line cycle pull drop down box allows the user to change the number of line cycles being used to accumulate the energy during calibration. After this occurs, the software automatically performs a write to the LINE_CYC register.

MCP3909 3-Phase Energy Meter Reference Design

6.9 METER DESIGN FRAME

This frame contains the editable options for the meter design. All fields in this box are editable with the exception of current resolution, voltage resolution, and power resolution. These 3 boxes are set based on the following 3 tables.

These tables are important and are used to calculate the resolution values that are used when calculating the _GLSB registers that occur while calibrating the meter.

It is these values that are also used to place the decimal point in the reading or results frame.

The resolutions presented here are based on the assumption that the I_{MAX} and V_{CAL} voltages will be at approximately 50% of the input voltage to the A/D converters. To change the headroom of the A/D input simply change the MAXIMUM current number and the GLSB registers will scale accordingly.

TABLE 6-2: CURRENT RESOLUTION TABLE

Maximum Current Less than or Equal To (A)	LSB Resolution (A)
8.1	0.001
81	0.01
810	0.1
8,100	1

TABLE 6-3: POWER RESOLUTION TABLE

Maximum Wattage Less than or Equal To (W - I _{MAX} times V _{CAL})	LSB Resolution (mW)
125	0.001
1,250	0.01
12,500	0.1
125,000	1
1,250,000	10
12,500,000	100

TABLE 6-4: VOLTAGE RESOLUTION TABLE

Maximum Voltage Less than or Equal To (V)	LSB Resolution (V)
ALL	0.1

Note that the decimal point location in the reading frame is updated whenever the V_{CAL}, I_{CAL}, or I_{MAX} values are changed.

3-Phase Energy Meter Calibration Software

6.10 MESSAGE LOG FRAME

The message log frame is located by clicking on the **Log** tab at the top of the screen.

Double clicking on the message frame copies the messages to the Windows clipboard for easy transfer in debugging situations.

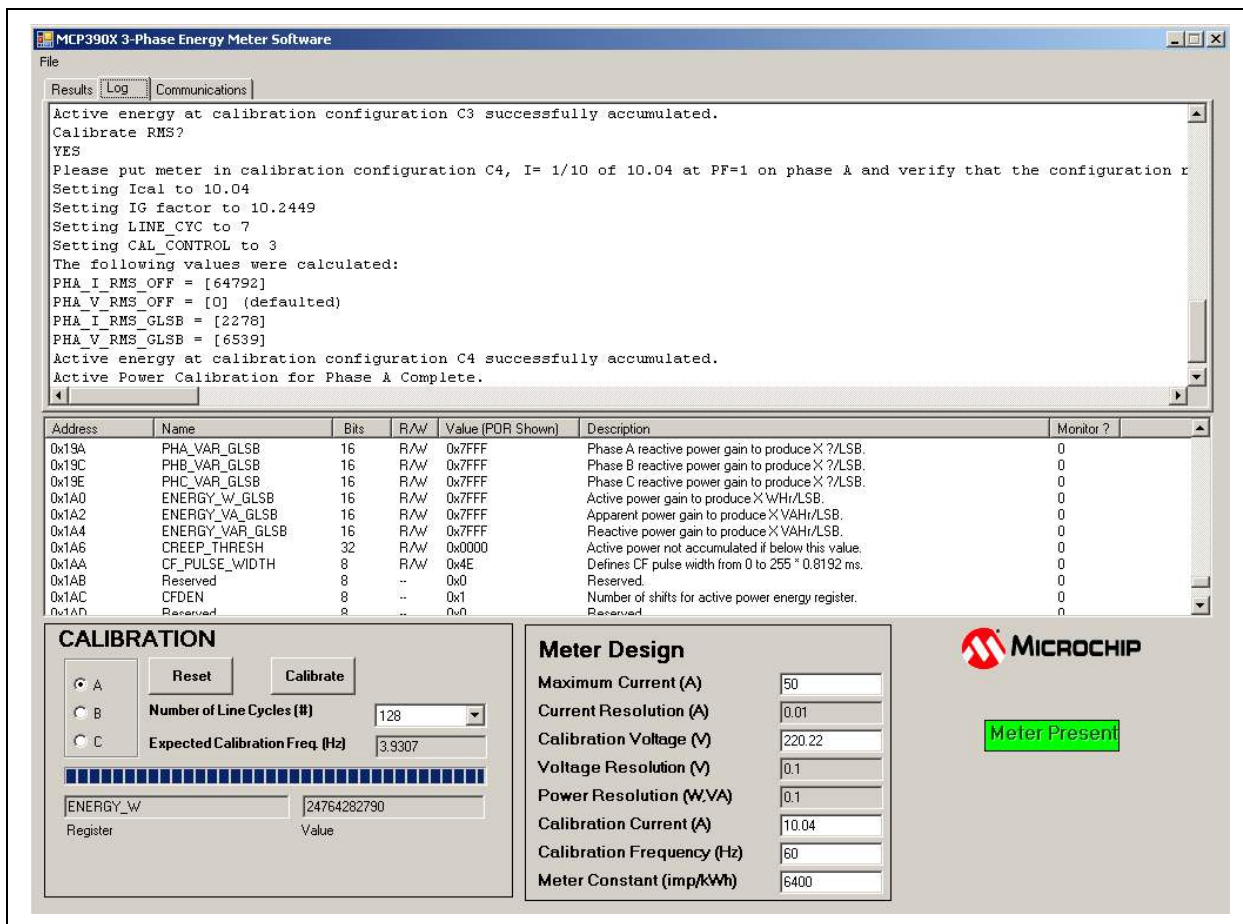

FIGURE 6-7: Main Screen with Message Log Frame Active.

MCP3909 3-Phase Energy Meter Reference Design

6.11 COMMUNICATIONS LOG FRAME

The communications log frame records all commands being sent to the PIC18F2520 through RS-232 and USB. This frame can be used to record communications activity when designing a customized meter calibration script.

The screenshot displays the MCP3909 3-Phase Energy Meter Software interface. The 'Communications' tab is active, showing a list of memory addresses and their corresponding values. Below the list is a table with columns for Address, Name, Bits, R/W, Value (PDR Shown), Description, and Monitor?. The table lists various registers such as PHA_VAR_GLSB, PHB_VAR_GLSB, PHC_VAR_GLSB, ENERGY_W_GLSB, ENERGY_VA_GLSB, ENERGY_VAR_GLSB, CREEP_THRESH, CF_PULSE_WIDTH, and CFDEN, along with their bit widths and descriptions.

Address	Name	Bits	R/W	Value (PDR Shown)	Description	Monitor ?
0x19A	PHA_VAR_GLSB	16	R/W	0x7FFF	Phase A reactive power gain to produce X ?/LSB.	0
0x19C	PHB_VAR_GLSB	16	R/W	0x7FFF	Phase B reactive power gain to produce X ?/LSB.	0
0x19E	PHC_VAR_GLSB	16	R/W	0x7FFF	Phase C reactive power gain to produce X ?/LSB.	0
0x1A0	ENERGY_W_GLSB	16	R/W	0x7FFF	Active power gain to produce X W/LSB.	0
0x1A2	ENERGY_VA_GLSB	16	R/W	0x7FFF	Apparent power gain to produce X VA/LSB.	0
0x1A4	ENERGY_VAR_GLSB	16	R/W	0x7FFF	Reactive power gain to produce X VAHr/LSB.	0
0x1A6	CREEP_THRESH	32	R/W	0x0000	Active power not accumulated if below this value.	0
0x1AA	CF_PULSE_WIDTH	8	R/W	0x4E	Defines CF pulse width from 0 to 255 * 0.8192 ms.	0
0x1AB	Reserved	8	--	0x0	Reserved.	0
0x1AC	CFDEN	8	--	0x1	Number of shifts for active power energy register.	0
0x1AD	Reserved	8	--	0x0	Reserved.	0

The interface also includes a 'CALIBRATION' section with radio buttons for A, B, and C, a 'Reset' button, a 'Calibrate' button, and input fields for 'Number of Line Cycles (#)' (128) and 'Expected Calibration Freq. (Hz)' (3.9307). A progress bar and a 'Register' value of 24764282790 are also visible. The 'Meter Design' section contains several input fields: Maximum Current (A) (50), Current Resolution (A) (0.01), Calibration Voltage (V) (220.22), Voltage Resolution (V) (0.1), Power Resolution (W/VA) (0.1), Calibration Current (A) (10.04), Calibration Frequency (Hz) (60), and Meter Constant (imp/kWh) (6400). The Microchip logo and a 'Meter Present' indicator are also present.

FIGURE 6-8: Main Screen with Communications Log Frame Active.

Appendix A. Schematic and Layouts

A.1 INTRODUCTION

This appendix contains the following schematics and layouts for Revision 2 of the MCP3909 3-Phase Energy Meter Reference Design:

- Main Board Schematic - Page 1
- Main Board Schematic - Page 2
- Main Board Schematic - Page 3
- Main Board Schematic - Page 4
- Main Board Schematic - Page 5
- Main Board - Top Layer And Silk-Screen
- Main Board - Bottom Layer
- USB Interface Module - Schematic
- USB Interface Module - Top Silk-Screen Layer
- USB Interface Module - Top Traces And Pads Layer
- USB Interface Module - Bottom Silk-Screen Layer
- USB Interface Module - Bottom Traces And Pads Layer

A.2 SCHEMATICS AND PCB LAYOUT

The layer order is shown in Figure A-1.

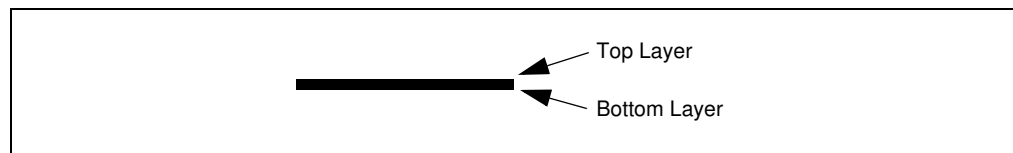
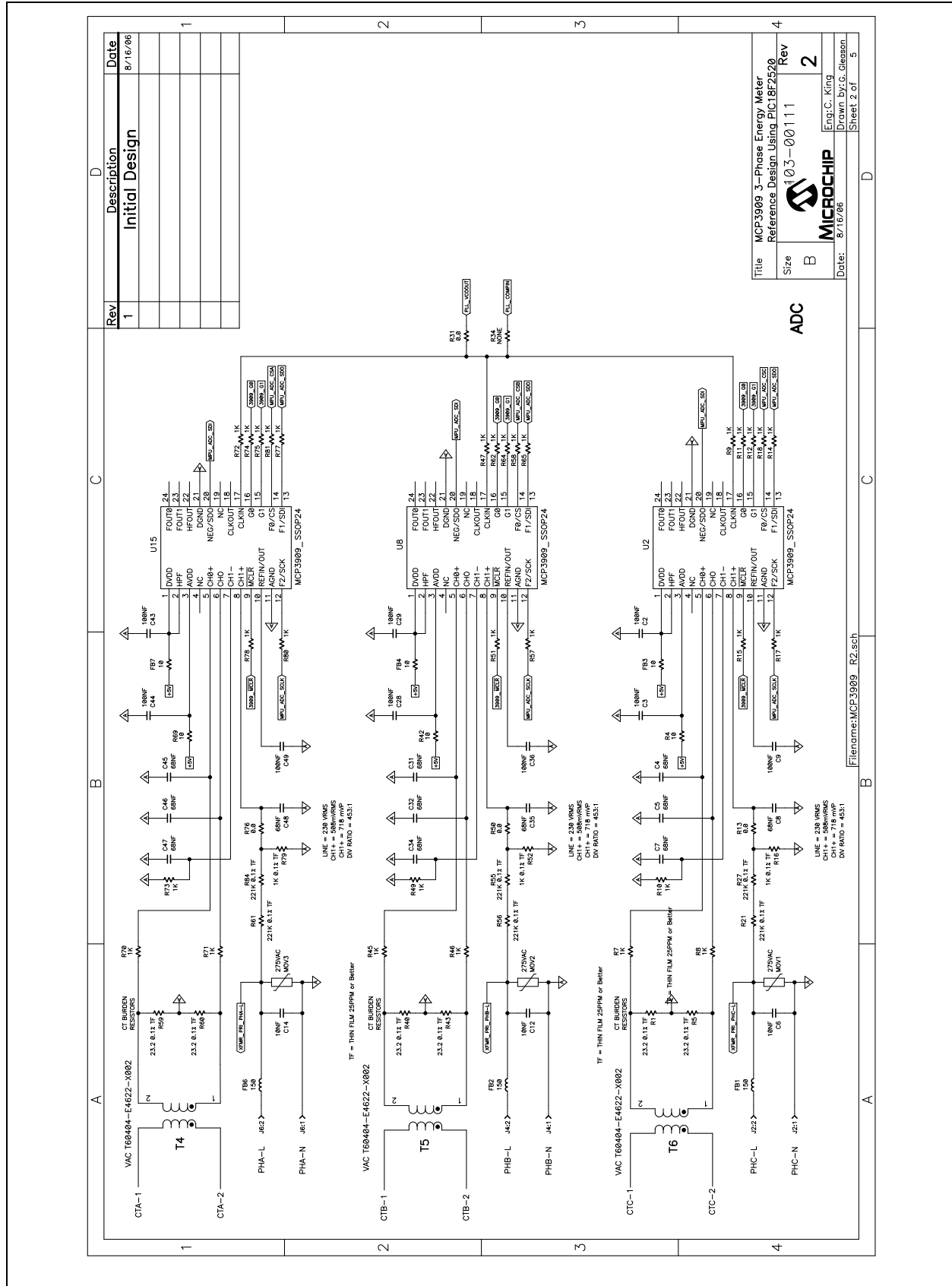

FIGURE A-1: *Layer Order*

A.4 MAIN BOARD SCHEMATIC - PAGE 2



MCP3909 3-Phase Energy Meter Reference Design

A.5 MAIN BOARD SCHEMATIC - PAGE 3

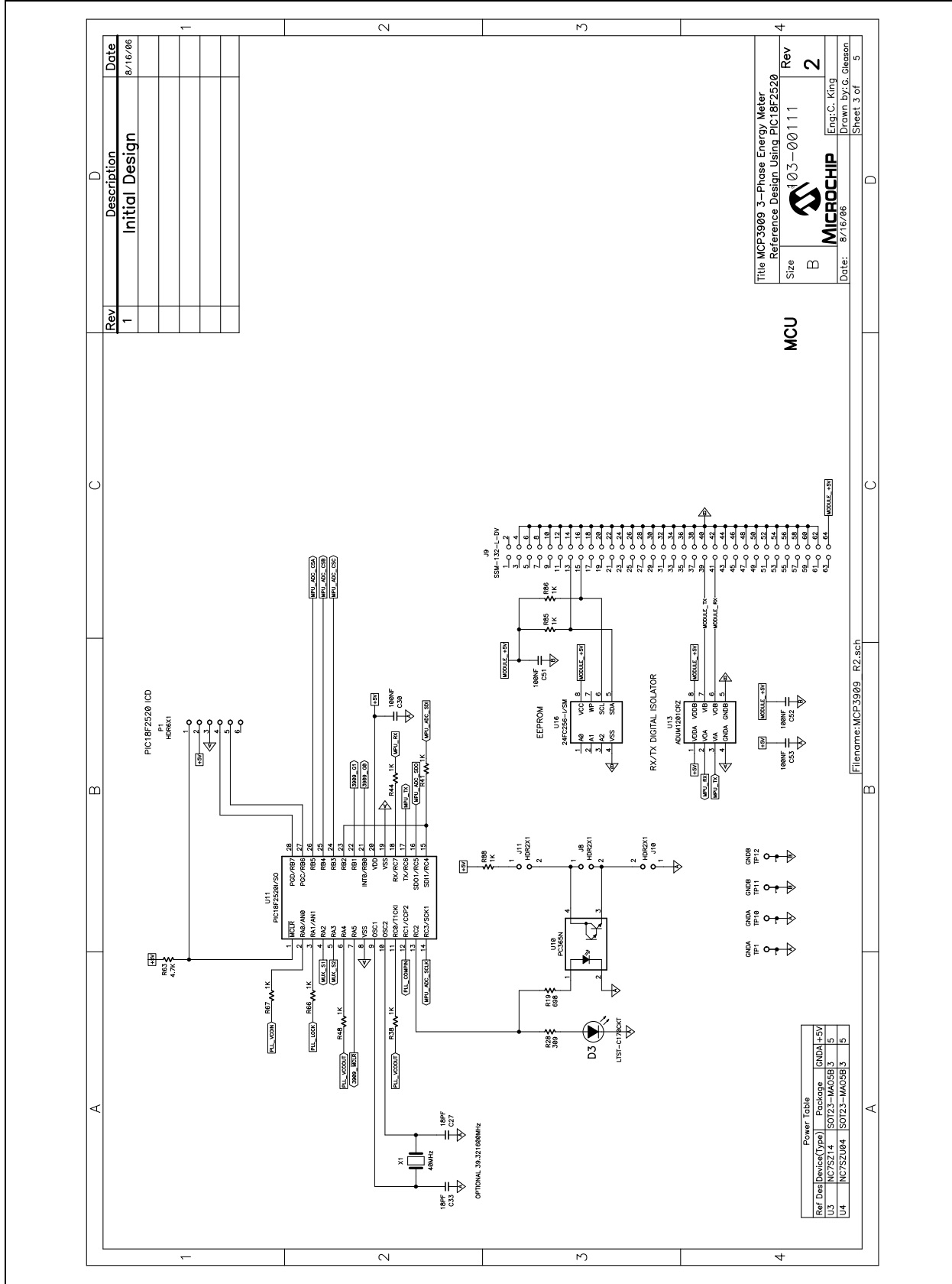

A.6 MAIN BOARD SCHEMATIC - PAGE 4

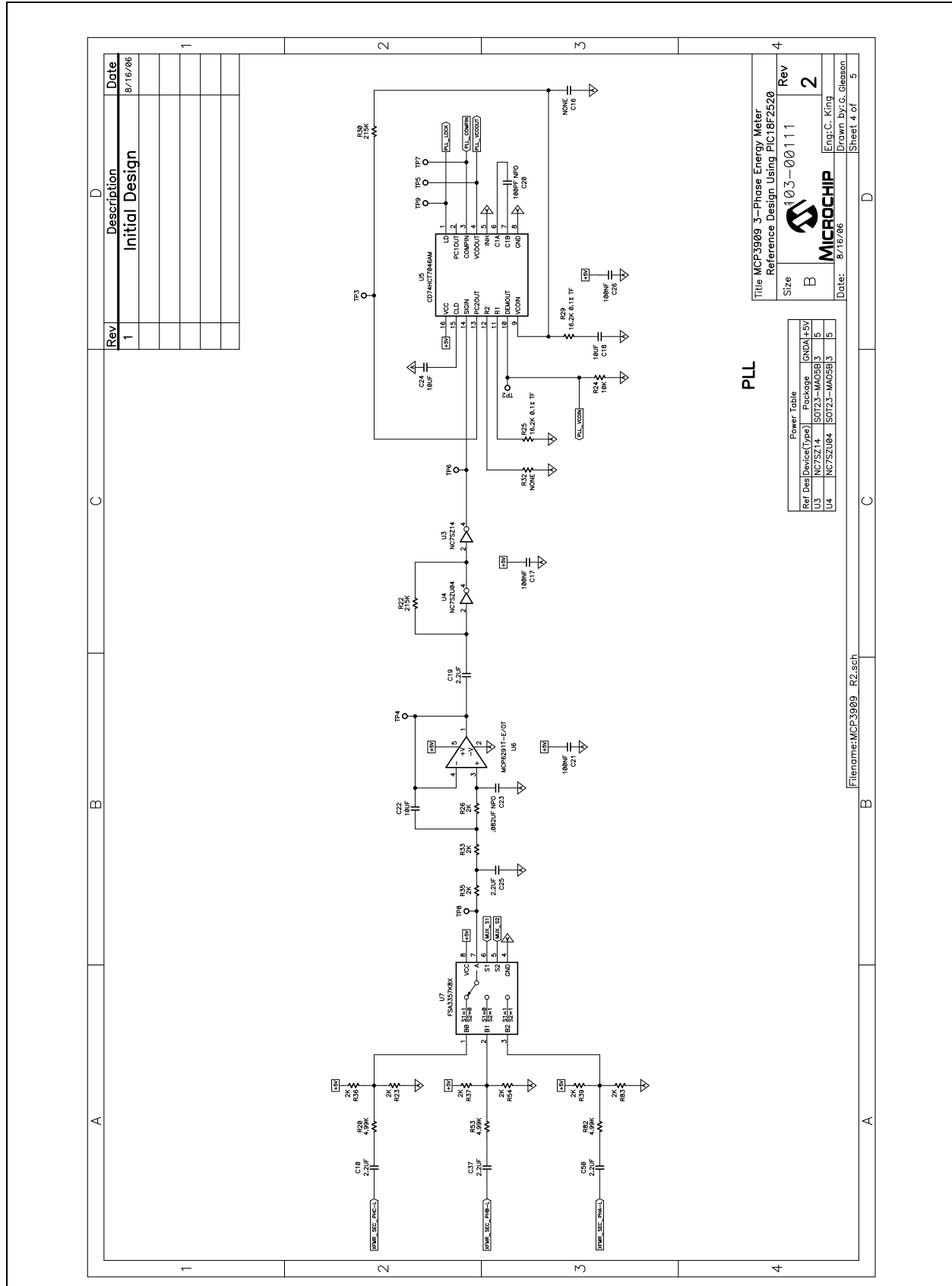

MCP3909 3-Phase Energy Meter Reference Design

A.7 MAIN BOARD SCHEMATIC - PAGE 5

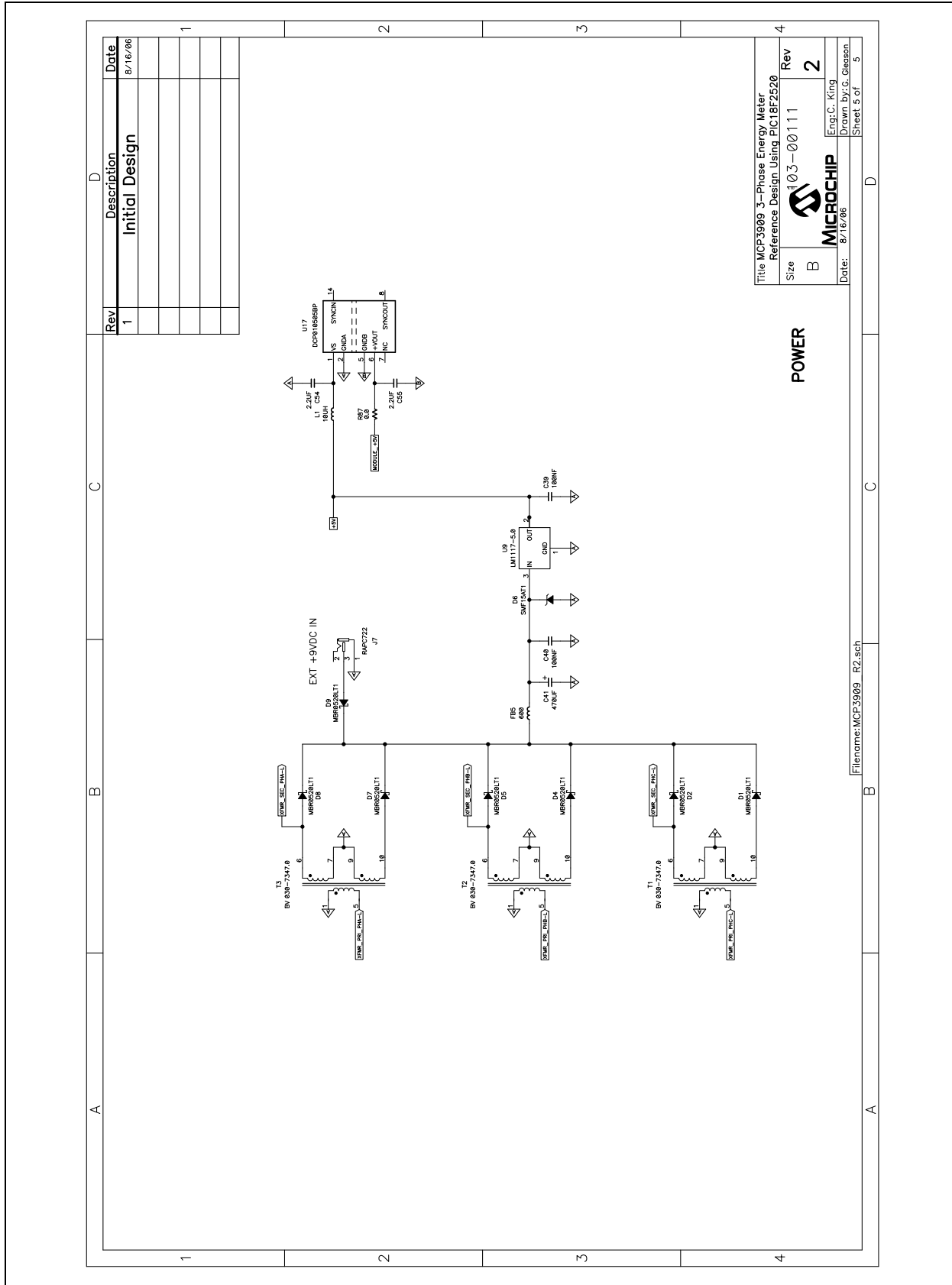

Rev	Description	Date
1	Initial Design	8/16/06

Title MCP3909 3-Phase Energy Meter Reference Design Using PIC18F2520	
Size B	Rev 2
Eng: C. King Drawn: B.V.G. Gleason Date: 8/16/06 Sheet 5 of 5	

POWER

Filename: MCP3909_R2.sch

A.8 MAIN BOARD - TOP LAYER AND SILK-SCREEN

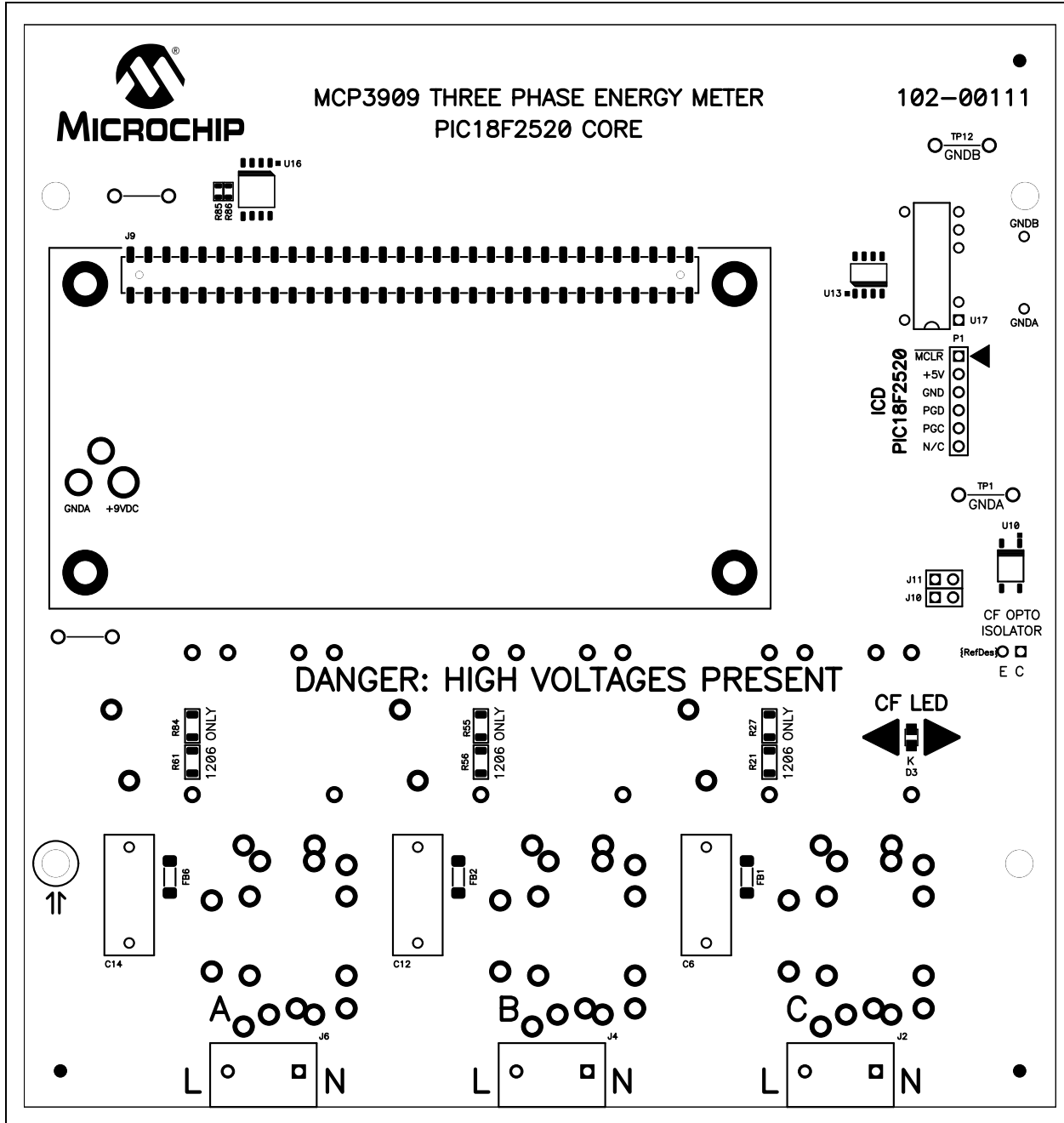

MCP3909 3-Phase Energy Meter Reference Design

A.9 MAIN BOARD - BOTTOM LAYER

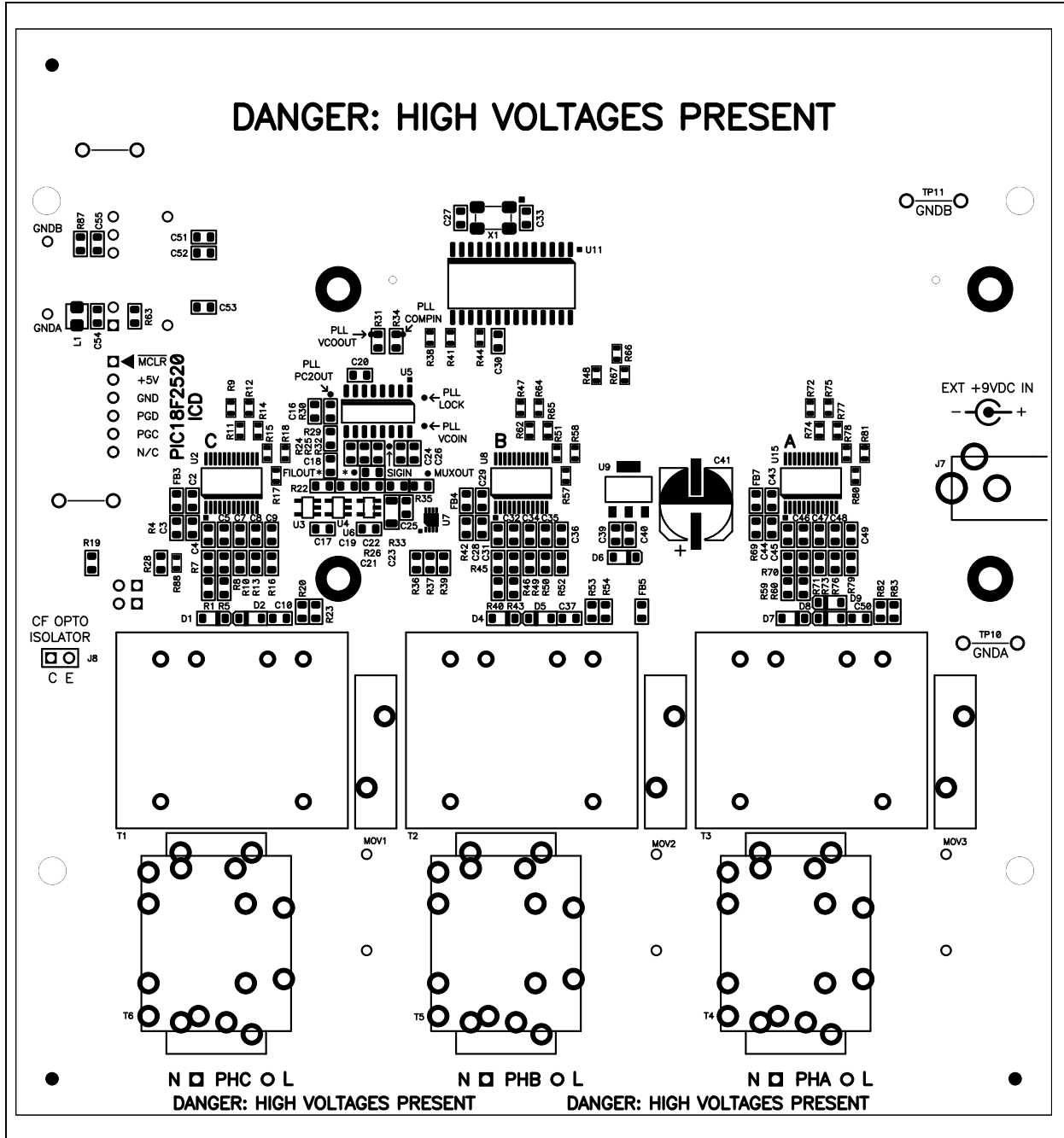

MCP3909 3-Phase Energy Meter Reference Design

A.11 USB INTERFACE MODULE - TOP SILK-SCREEN LAYER

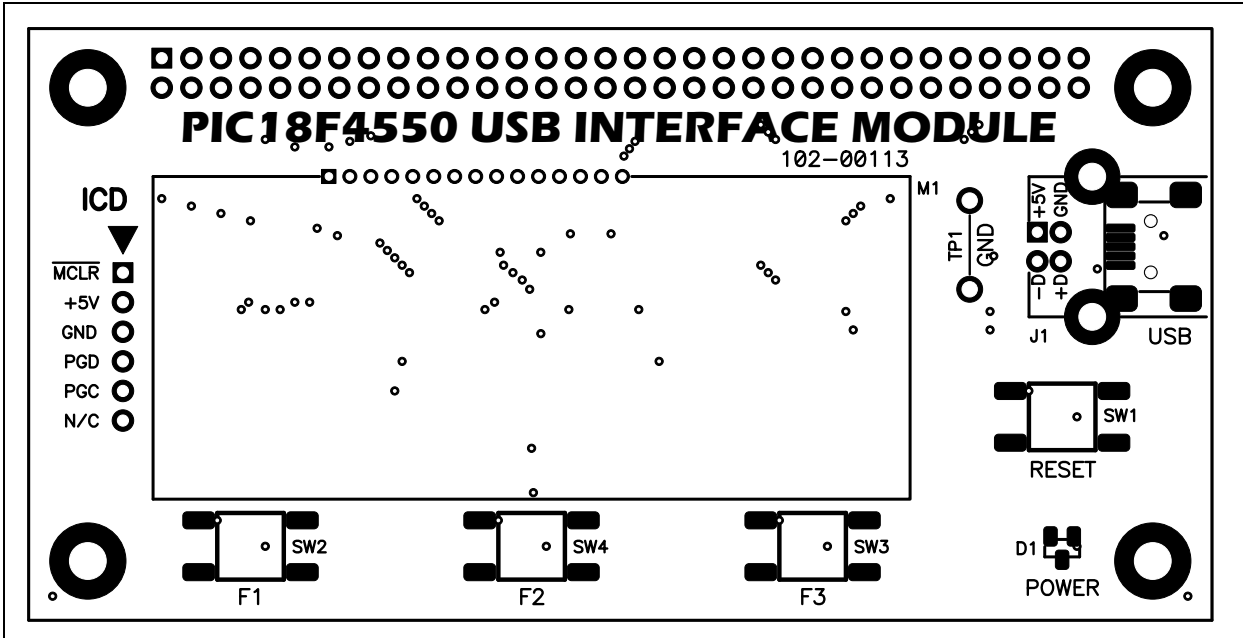

A.12 USB INTERFACE MODULE - TOP TRACES AND PADS LAYER

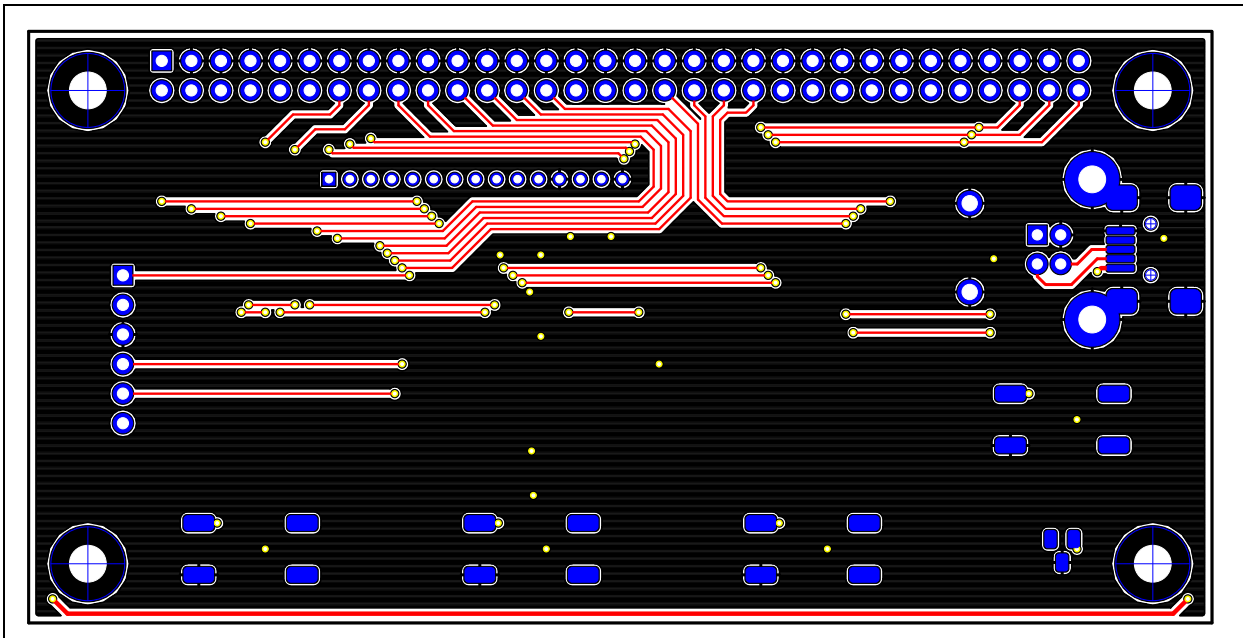

A.13 USB INTERFACE MODULE - BOTTOM SILK-SCREEN LAYER

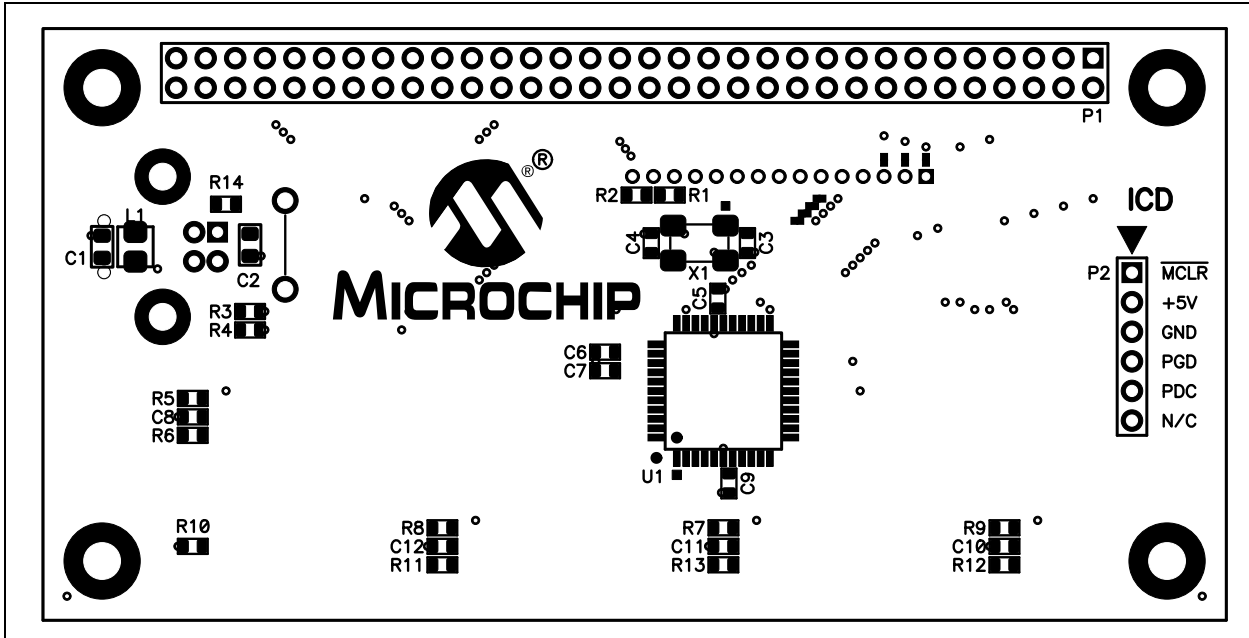

A.14 USB INTERFACE MODULE - BOTTOM TRACES AND PADS LAYER

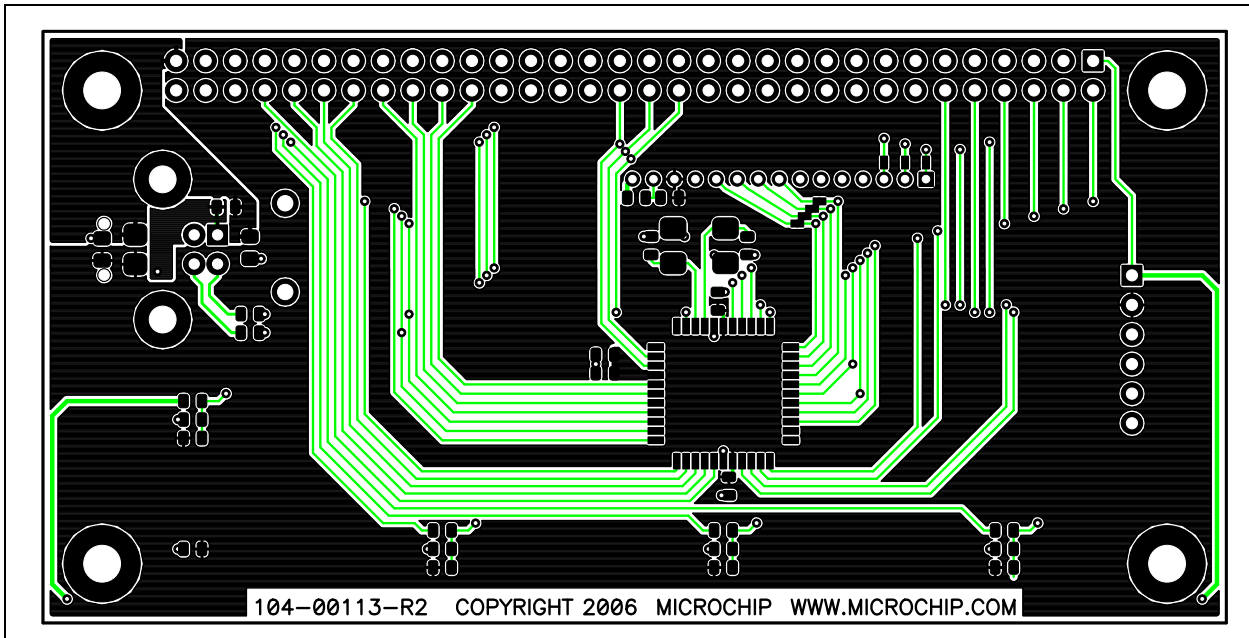

MCP3909 3-Phase Energy Meter Reference Design

NOTES:

Appendix B. Bill Of Materials (BOM)

TABLE B-1: MAIN BOARD - BILL OF MATERIALS (BOM)

Qty	Reference	Description	Manufacturer	Part Number
4	C1, C11, C13, C16	DO NOT POPULATE	—	—
18	C2, C3, C9, C17, C21, C26, C28, C29, C30, C36, C39, C40, C43, C44, C49, C51, C52, C53	CAP .1UF 25V CERAMIC X7R 0805	Panasonic® - ECG	ECJ-2VB1E104K
12	C4, C5, C7, C8, C31, C32, C34, C35, C45, C46, C47, C48	CAP 68000PF 25V CERM X7R 0805	Panasonic - ECG	ECJ-2VB1E683K
3	C6, C12, C14	DO NOT POPULATE	—	—
7	C10, C19, C25, C37, C50, C54, C55	CAP CER 2.2UF 10V 10% X7R 0805	Murata Electronics® North America	GRM21BR71A225KA01L
3	C18, C22, C24	CAP CER 10UF 10V 10% X5R 0805	Murata Electronics North America	GRM21BR61A106KE19L
1	C20	CAP CER 100PF 100V 5% C0G 0805	Murata Electronics North America	GRM2165C2A101JA01D
1	C23	CAP CERM .082UF 5% 50V NPO 1206	Murata Electronics North America	GRM31C5C1H823JA01L
2	C27, C33	CAP CERAMIC 18PF 50V NP0 0805	Kemet Electronics®	C0805C180J5GACTU
1	C41	CAP 470UF 25V ELECT FC SMD	Panasonic - ECG	EEE-FC1E471P
7	D1, D2, D4, D5, D7, D8, D9	DIODE SCHOTTKY 20V 0.5A SOD123	ON Semiconductor®	MBR0520LT1G
1	D3	LED RED CLEAR 0805 SMD	LITE-ON INC	LTST-C170CKT
1	D6	TVS ZENER 200W 15V SOD123FL	ON Semiconductor	SMF15AT1G
3	FB1, FB2, FB6	150 Ohm 300mA 1806 Ferrite Chip	Steward	LI1806C151R-10
6	FB3, FB4, FB7, R4, R42, R69	RES 10.0 OHM 1/8W 1% 0805 SMD	Yageo® Corporation	RC0805FR-0710RL
1	FB5	FERRITE 500MA 600 OHM 0805 SMD	Steward	HZ0805E601R-10
3	J2, J4, J6	TERMINAL BLOCK 10MM VERT 2POS	On Shore Technology	ED200/2DS
1	J7	DO NOT POPULATE CONN POWER JACK 2.5MM PCB CIRC	—	—
1	J8	6 X 1 Header 2.54mm on center 6 mm/2.5mm	Samtec	TSW-102-07-G-S
2	J9	64-pin Surface Mount Header 0.1" Centers	Samtec	SSM-132-L-DV

Note 1: The components listed in this Bill of Materials are representative of the PCB assembly. The released BOM used in manufacturing uses all RoHS-compliant components.

MCP3909 3-Phase Energy Meter Reference Design

TABLE B-1: MAIN BOARD - BILL OF MATERIALS (BOM) (CONTINUED)

Qty	Reference	Description	Manufacturer	Part Number
1	L1	10uH Inductor	Coilcraft	0805PS-103KL
3	MOV1, MOV2, MOV3	VARISTOR 275VRMS 20MM RADIAL	LITTELFUSE	V20E275P
1	P1	6 X 1 Header 2.54mm on center 6 mm/2.5mm	Samtec	TSW-106-07-G-S
1	PCB	RoHS Compliant Bare PCB, MCP3909 3-Phase Energy Meter Reference Design Using PIC18F2520	Microchip Technology Inc.	104-00111
6	R1, R5, R40, R43, R59, R60	RES 23.2 OHM 1/8W 0.1% 25PPM TF 0805 SMD	KOA Speer Yageo Corporation	RN732ALTDK23R2B25
9	R7, R8, R10, R45, R46 R49, R70, R71, R73	RES 1.00K OHM 1/8W 1% 0805 SMD	Panasonic - ECG	ERJ-6ENF1001V
30	R9, R11, R12, R14, R15, R17, R18, R38, R41, R44, R47, R48, R51, R57, R58, R62, R64, R65, R66, R67, R72, R74, R75, R77, R78, R80, R81, R85, R86, R88	RES 1.0K OHM 1/16W .1% 0603 SMD	Susumu Co Ltd	RR0816P-102-B-T5
5	R13, R31, R50, R76, R87	RES 0.0 OHM 1/8W 5% 0805 SMD	Panasonic - ECG	ERJ-6GEY0R00V
3	R16, R52, R79	RES 1.00K OHM 1/8W 0.1% 25PPM TF 0805 SMD	Susumu Co Ltd	RG2012P-102-B-T5
1	R19	RES 698 OHM 1/8W 1% 0805 SMD	Yageo Corporation	RC0805FR-07698RL
3	R20, R53, R82	RES 4.99K OHM 1/8W 1% 0805 SMD	Yageo Corporation	RC0805FR-074K99L
6	R21, R27, R55, R56, R61, R84	RES 221K OHM 1/8W 0.1% 25PPM TF 0805 SMD	Susumu Co Ltd	RG3216N-2213-B-T1
2	R22, R30	RES 215K OHM 1/8W 1% 0805 SMD	Yageo Corporation	RC0805FR-07215KL
9	R23, R26, R33, R35, R36, R37, R39, R54, R83	RES 2.00K OHM 1/8W 1% 0805 SMD	Panasonic - ECG	ERJ-6ENF2001V
1	R24	RES 10.0K OHM 1/8W 1% 0805 SMD	Yageo Corporation	RC0805FR-0710KL
2	R25, R29	RES 16.2K OHM 1/8W 1% SMD 0805	Yageo Corporation	RT0805FRE0716K2L
1	R28	RES 309 OHM 1/8W 1% 0805 SMD	Yageo Corporation	RC0805FR-07309RL
2	R32, R34	DO NOT POPULATE	—	—
1	R63	RES 4.7K OHM 1/8W 5% 0805 SMD	Yageo Corporation	RC0805JR-074K7L
3	T1, T2, T3,	TRANSFORMER 230V 2.3VA 2X9V	TransERA Electronics Inc	BV030-7347.0
3	T4, T5, T6	5A/2.5mA Current Transformer	Shanghai He Hua Electronic Co. Ltd	SCT954F
4	TP1, TP10, TP11, TP12	Wire Test Point 0.3" Length	Component Corporation	PJ-202-30
8	TP2 <->TP9	DO NOT POPULATE	—	—
1	U13	IC ISOLATOR DIGITAL DUAL 8-SOIC	Analog Devices Inc	ADUM1201CRZ-RL7

Note 1: The components listed in this Bill of Materials are representative of the PCB assembly. The released BOM used in manufacturing uses all RoHS-compliant components.

Bill Of Materials (BOM)

TABLE B-1: MAIN BOARD - BILL OF MATERIALS (BOM) (CONTINUED)

Qty	Reference	Description	Manufacturer	Part Number
3	U2, U8, U15	Energy Meter ADC SSOP24	Microchip Technology Inc.	MCP3909-I/SS
1	U3	IC INVERTER SCHMITT INPUT SOT-23	Fairchild Semiconductor®	NC7SZ14M5X
1	U4	IC INVERTER UNBUFFERED SOT23-5	Fairchild Semiconductor	NC7SZU04M5X
1	U5	IC PLL W/VCO/LOCK DETECT 16-SOIC	Texas Instruments	CD74HCT7046AM
1	U6	Op-amp SOT23-5	Microchip Technology Inc.	MCP6291T-E/OT
1	U7	IC SWITCH ANALOG SP3T LV US8	Fairchild Semiconductor	FSA3357K8X
1	U9	IC REG 5.0V 800MA LDO SOT-223	National Semiconductor	LM1117MPX-5.0
1	U10	PHOTOCOUPLER DARL OUT 4-SMD	Sharp Microelectronics	PC365NJ0000F
1	U11	Flash Microcontroller with 10-Bit A/D	Microchip Technology Inc.	PIC18F2520I/SO
1	U16	256K I2C™ CMOS Serial EEPROM	Microchip Technology Inc.	24FC256-I/SM
1	U17	IC ISO DC/DC CONV 5V/5V 14-DIP	Texas Instruments	DCP010505BP
1	X1	CRYSTAL 40.0000MHZ 10PF SMD	Abracon Corporation	ABM3B-40.000MHZ-10-1-U-T

Note 1: The components listed in this Bill of Materials are representative of the PCB assembly. The released BOM used in manufacturing uses all RoHS-compliant components.

MCP3909 3-Phase Energy Meter Reference Design

TABLE B-2: USB INTERFACE MODULE - BILL OF MATERIALS (BOM)

Qty	Reference	Description		
2	C1, C2	CAP CER 10UF 16V X5R 0805	Murata Electronics	GRM21BR61C106KE15L
2	C3, C4	CAP CER 18PF 50V 5% C0G 0603	Murata Electronics	GQM1885C1H180JB01D
8	C5, C6, C7, C8, C9, C10, C11, C12	CAP CER .1UF 16V 10% X7R 0603	Murata Electronics	GRM188R71C104KA01D
1	D1	Red LED SOT-23	SunLED	XZUR48WA
0	J1	DO NOT POPULATE CONN USB RTANG FEMALE TYPE B PCB	—	—
1	J2	CONN RECEPT MINI USB2.0 5POS	Hirose Electronic Co. Ltd	UX60-MB-5ST
1	L1	Power Chip Inductors -0805PS Series	Coilcraft	0805PS-103KL
1	M1	16 X 2 LCD Character Display	Fema	CG1626-SGR1-Z
1	P1	CONN HEADER 64POS .100 VERT GOLD	http://www.samtec.com	MTSW-132-23-L-D-240
1	P2	CONN HEADER 6POS .100 R/A TIN	Molex/Waldom Elec- tronics Corp	22-05-2061
1	PCB	USB Interface Module	Microchip Technology Inc.	102-00113
1	R1	RES 523 OHM 1/10W 1% 0603 SMD	Panasonic - ECG	ERJ-3EKF5230V
5	R2, R6, R11, R12, R13	RES 4.70K OHM 1/10W 1% 0603 SMD	Rohm	MCR03EZPFX4701
2	R3, R4	RES 24.9 OHM 1/10W 1% 0603 SMD	Panasonic - ECG	ERJ-3EKF24R9V
4	R5, R7, R8, R9	RES 1.00K OHM 1/10W 1% 0603 SMD	Panasonic - ECG	ERJ-3EKF1001V
1	R10	RES 332 OHM 1/10W 1% 0603 SMD	Panasonic - ECG	ERJ-3EKF3320V
0	R14	DO NOT POPULATE	—	—
4	SW1, SW2, SW3, SW4	Pushbutton Tact Switch 6mm SMD Mom 230gF	Omron	B3S-1002
1	TP1	Wire Test Point 0.3" Length	Nedco Electronics	PJ-202-30
1	U1	High-Performance, Enhanced Flash, USB Microcontroller 44-Pin, QFP	Microchip Technology Inc.	PIC18F4550
1	X1	CRYSTAL 20.0000MHZ 10PF SMD	Abracon Corporation	ABM3B-20.000MHZ-10-1-U-T

Note 1: The components listed in this Bill of Materials are representative of the PCB assembly. The released BOM used in manufacturing uses all RoHS-compliant components.

Bill Of Materials (BOM)

NOTES:



WORLDWIDE SALES AND SERVICE

AMERICAS

Corporate Office

2355 West Chandler Blvd.
Chandler, AZ 85224-6199
Tel: 480-792-7200
Fax: 480-792-7277
Technical Support:
<http://support.microchip.com>
Web Address:
www.microchip.com

Atlanta

Duluth, GA
Tel: 678-957-9614
Fax: 678-957-1455

Boston

Westborough, MA
Tel: 774-760-0087
Fax: 774-760-0088

Chicago

Itasca, IL
Tel: 630-285-0071
Fax: 630-285-0075

Dallas

Addison, TX
Tel: 972-818-7423
Fax: 972-818-2924

Detroit

Farmington Hills, MI
Tel: 248-538-2250
Fax: 248-538-2260

Kokomo

Kokomo, IN
Tel: 765-864-8360
Fax: 765-864-8387

Los Angeles

Mission Viejo, CA
Tel: 949-462-9523
Fax: 949-462-9608

Santa Clara

Santa Clara, CA
Tel: 408-961-6444
Fax: 408-961-6445

Toronto

Mississauga, Ontario,
Canada
Tel: 905-673-0699
Fax: 905-673-6509

ASIA/PACIFIC

Asia Pacific Office

Suites 3707-14, 37th Floor
Tower 6, The Gateway
Harbour City, Kowloon
Hong Kong
Tel: 852-2401-1200
Fax: 852-2401-3431

Australia - Sydney

Tel: 61-2-9868-6733
Fax: 61-2-9868-6755

China - Beijing

Tel: 86-10-8528-2100
Fax: 86-10-8528-2104

China - Chengdu

Tel: 86-28-8665-5511
Fax: 86-28-8665-7889

China - Hong Kong SAR

Tel: 852-2401-1200
Fax: 852-2401-3431

China - Nanjing

Tel: 86-25-8473-2460
Fax: 86-25-8473-2470

China - Qingdao

Tel: 86-532-8502-7355
Fax: 86-532-8502-7205

China - Shanghai

Tel: 86-21-5407-5533
Fax: 86-21-5407-5066

China - Shenyang

Tel: 86-24-2334-2829
Fax: 86-24-2334-2393

China - Shenzhen

Tel: 86-755-8203-2660
Fax: 86-755-8203-1760

China - Wuhan

Tel: 86-27-5980-5300
Fax: 86-27-5980-5118

China - Xiamen

Tel: 86-592-2388138
Fax: 86-592-2388130

China - Xian

Tel: 86-29-8833-7252
Fax: 86-29-8833-7256

China - Zhuhai

Tel: 86-756-3210040
Fax: 86-756-3210049

ASIA/PACIFIC

India - Bangalore

Tel: 91-80-4182-8400
Fax: 91-80-4182-8422

India - New Delhi

Tel: 91-11-4160-8631
Fax: 91-11-4160-8632

India - Pune

Tel: 91-20-2566-1512
Fax: 91-20-2566-1513

Japan - Yokohama

Tel: 81-45-471- 6166
Fax: 81-45-471-6122

Korea - Daegu

Tel: 82-53-744-4301
Fax: 82-53-744-4302

Korea - Seoul

Tel: 82-2-554-7200
Fax: 82-2-558-5932 or
82-2-558-5934

Malaysia - Kuala Lumpur

Tel: 60-3-6201-9857
Fax: 60-3-6201-9859

Malaysia - Penang

Tel: 60-4-227-8870
Fax: 60-4-227-4068

Philippines - Manila

Tel: 63-2-634-9065
Fax: 63-2-634-9069

Singapore

Tel: 65-6334-8870
Fax: 65-6334-8850

Taiwan - Hsin Chu

Tel: 886-3-572-9526
Fax: 886-3-572-6459

Taiwan - Kaohsiung

Tel: 886-7-536-4818
Fax: 886-7-536-4803

Taiwan - Taipei

Tel: 886-2-2500-6610
Fax: 886-2-2508-0102

Thailand - Bangkok

Tel: 66-2-694-1351
Fax: 66-2-694-1350

EUROPE

Austria - Wels

Tel: 43-7242-2244-39
Fax: 43-7242-2244-393

Denmark - Copenhagen

Tel: 45-4450-2828
Fax: 45-4485-2829

France - Paris

Tel: 33-1-69-53-63-20
Fax: 33-1-69-30-90-79

Germany - Munich

Tel: 49-89-627-144-0
Fax: 49-89-627-144-44

Italy - Milan

Tel: 39-0331-742611
Fax: 39-0331-466781

Netherlands - Drunen

Tel: 31-416-690399
Fax: 31-416-690340

Spain - Madrid

Tel: 34-91-708-08-90
Fax: 34-91-708-08-91

UK - Wokingham

Tel: 44-118-921-5869
Fax: 44-118-921-5820