

DF60F IN-LINE TYPE RECOMMENDED PANEL MOUNTING MANUAL (WHEN NUTS USES)

NUT INSTALLATION PROCESS

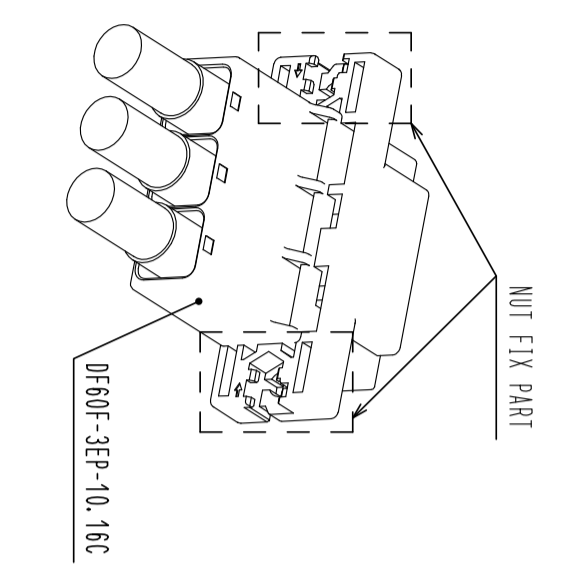

1. SLIDE A NUT (SIZE:M3) TO NUT FIX PART.

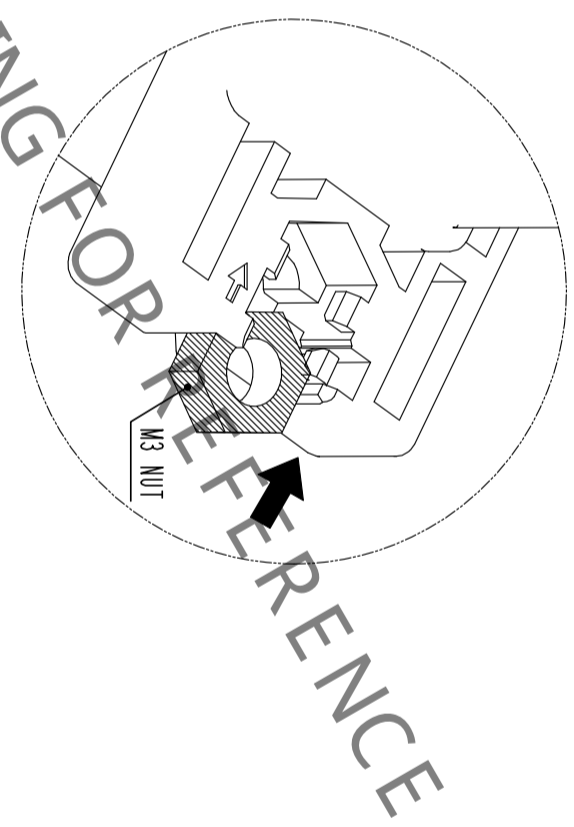

2. PRESS DOWN THE NUT UNTIL IT CLICKS, THEN THIS SOUND MEANS THE NUT HAS INSERTED INTO NUT HOLDER.

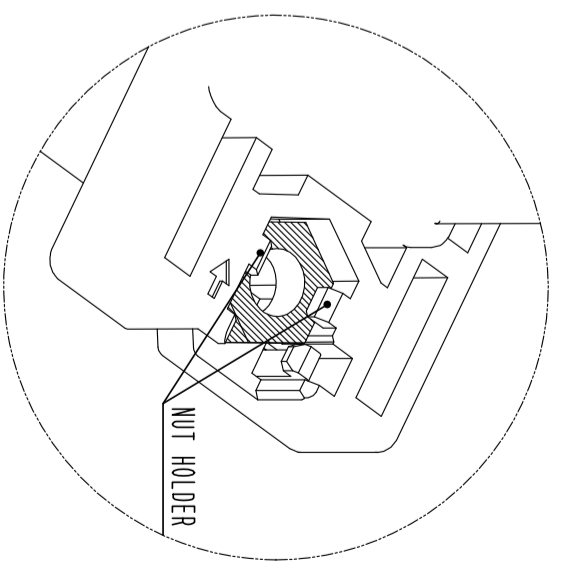

PANEL MOUNTING PROCESS

1. INSERT CONNECTOR INTO PANEL CUT OUT PART.

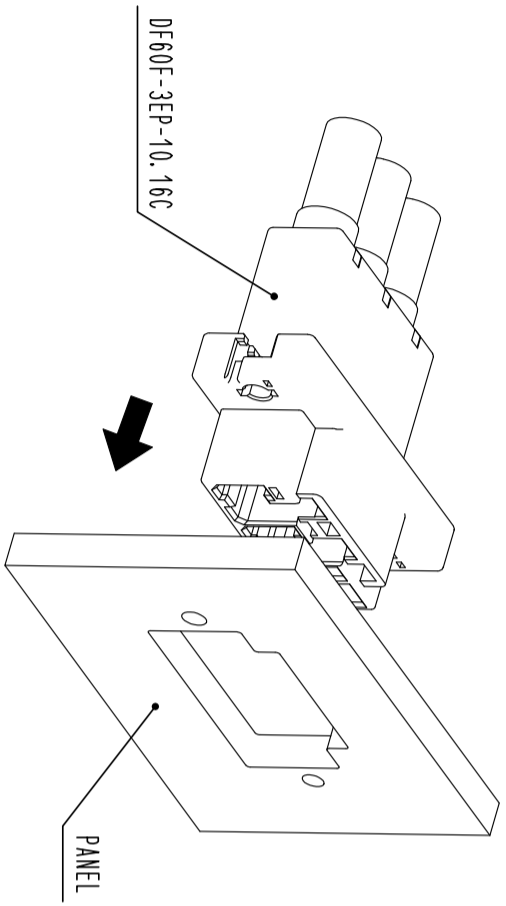

2. TIGHTEN A SCREW (SIZE:M3) TO FIX WITH PANEL.
RECOMMENDED TORQUE : LESS THAN 0.49N · m

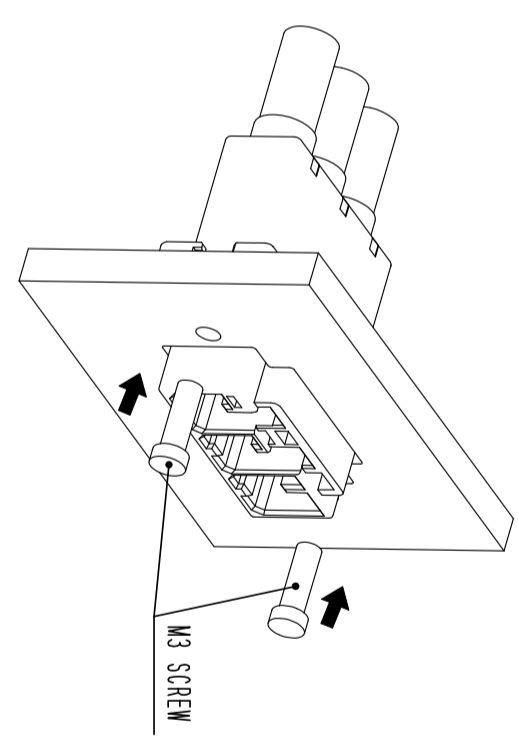

HR'S DRAWING FOR REFERENCE

FORM HC0011-5-8-AN	1	2	3	4	5	6	7	8
DRAWING NO.	EDC-379292-00-00							
PART NO.	DF60FR-3EP-10.16C							
CODE NO.	CL680-4006-0-00							
								3/2