

EC axial fans

Series W3G250 Ø 280 x 280 x 80 mm



Highlights:

- Control Input: 0-10 VDC/PWM
- Output: 10 VDC, max 1.1 mA
- Tach Output
- Over-temperature protected electronics
- Soft start, motor current limit
- Locked rotor protection

Material: Impeller: PP plastic
Electronic housing: Die-cast aluminum

Mounting position: Any

Condensate discharge holes: None, open rotor

Direction of rotation: Counter-clockwise, seen on rotor

Nominal Data

Type	Motor	Air flow cfm	Phase	Voltage VAC	Voltage range VDC	Frequency Hz	Power input (1) W	Speed (1) rpm	Current draw (1) A	Max back pressure in. H ₂ O	Temperature range (1) °C	Mass lbs	Bearing	Ingress protection rating	UL	Chart
W3G250-HK35-11	M3G055-CF	1120	1~	115V	100...130	50/60	125	2700	1.9	0.52	-25...60	7.62	Ball	IP54	Yes	Ⓒ
W3G250-HK19-11	M3G055-CF	1120	1~	230V	200...240	50/60	125	2700	1.1	-	-25...60	7.62	Ball	IP54	Yes	Ⓒ
W3G250-HH07-03	M3G055-CF	1000	1~	230V	200...240	50/60	83	2330	0.72	-	-25...60	4.62	Ball	IP54	Yes	Ⓑ
W3G250-HH53-03	M3G055-CF	846	1~	115V	100...130	50/60	56	2040	0.9	0.32	-25...50	4.62	Ball	IP54	Yes	Ⓐ

(1) Nominal data at maximum load.

Curves

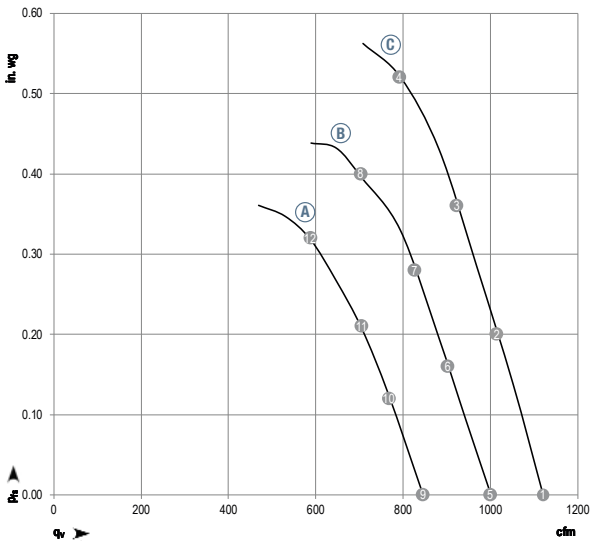

Air performance measured as per: ISO 5801, Installation category A, without protection against accidental contact.

Suction-side noise levels: L_{WA} as per ISO 13347, L_{PA} measured at 1m distance to fan axis.

The values given are valid under the measuring conditions mentioned and may vary according to the actual installation situation.

With any deviation to the standard set-up, the specific values have to be checked and reviewed once installed or fitted.

For detailed information on the measuring set-up, please contact ebm-papst.

	n rpm	Pe W	I _{230V} A	I _{115V} A	L _{pAin} dB(A)	L _{WAin} dB(A)
--	----------	---------	------------------------	------------------------	----------------------------	----------------------------

1	2845	96	0.83	1.43	64	70
2	2795	109	0.93	1.61	64	70
3	2755	119	1.01	1.72	64	71
4	2700	125	1.10	1.90	64	71
5	2465	67	0.59	-	62	69
6	2410	75	0.65	-	61	69
7	2375	80	0.68	-	61	68
8	2330	83	0.72	-	60	68
9	2133	43	-	0.72	57	65
10	2101	49	-	0.80	57	65
11	2087	52	-	0.84	57	64
12	2054	55	-	0.90	60	66

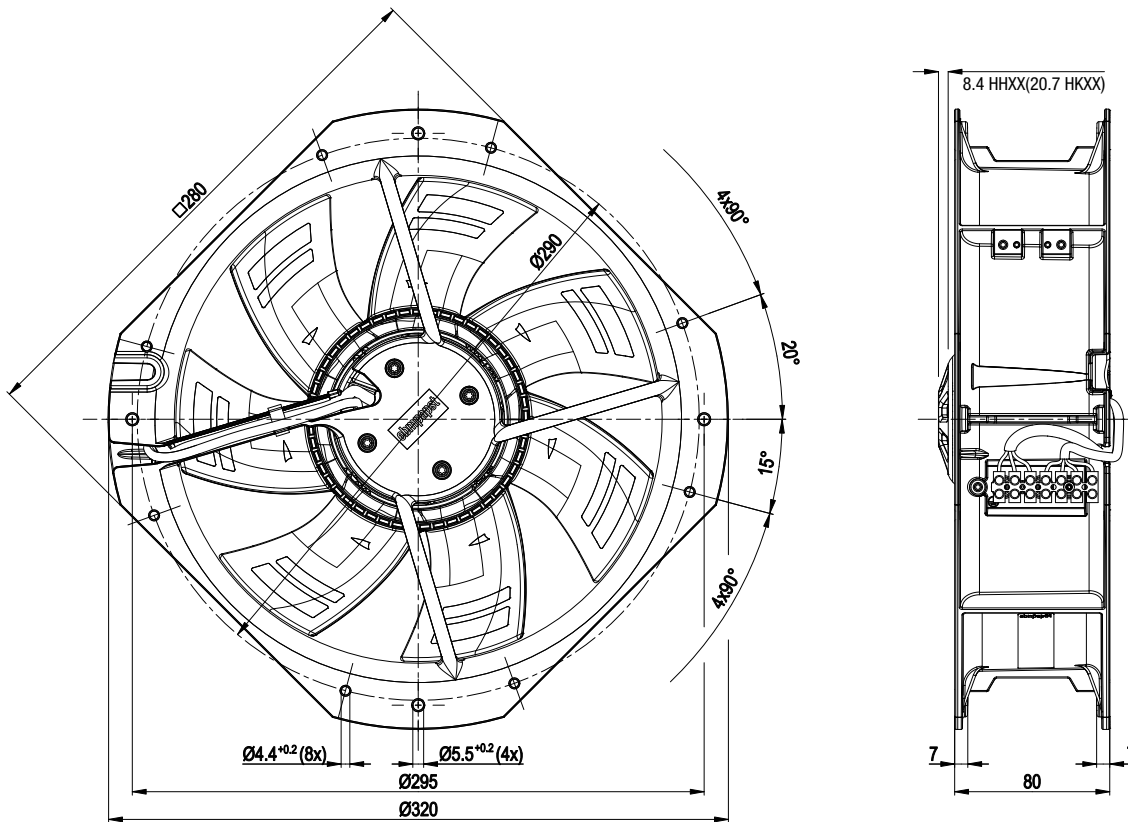

Connection screen

