

ALTERNATIVE DESIGN C

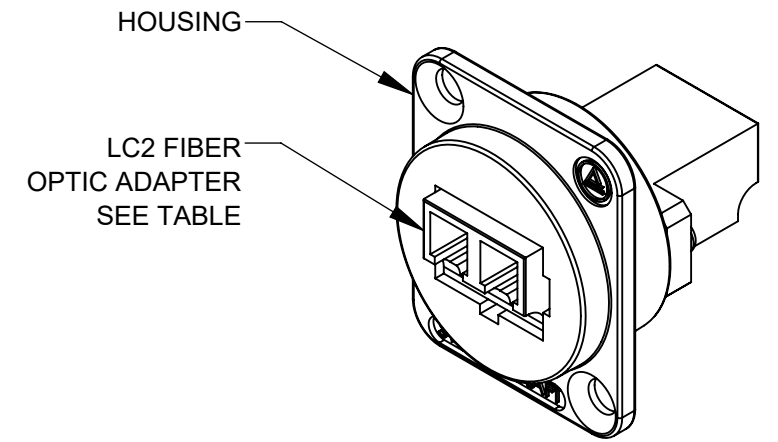

PART NUMBER	LC2 ADAPTER	ADAPTER COLOR
EHLC2	SINGLE-MODE	BLUE
EHLC2M	MULTI-MODE	BEIGE

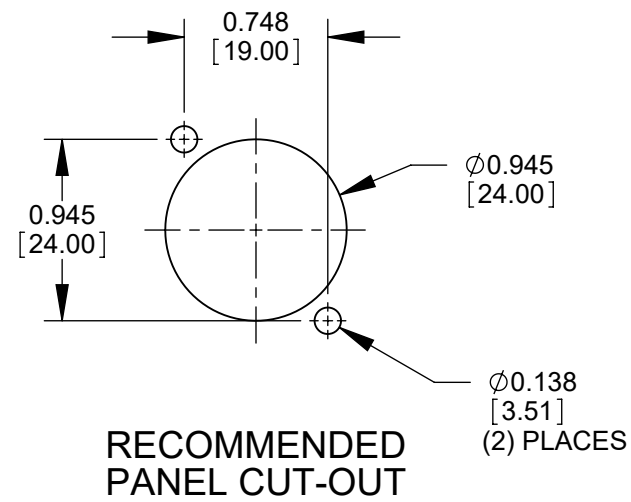
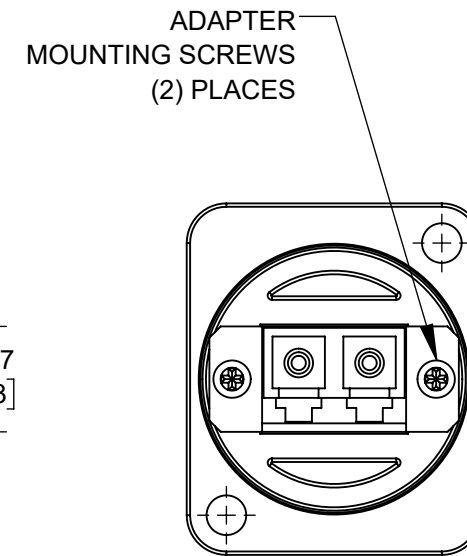
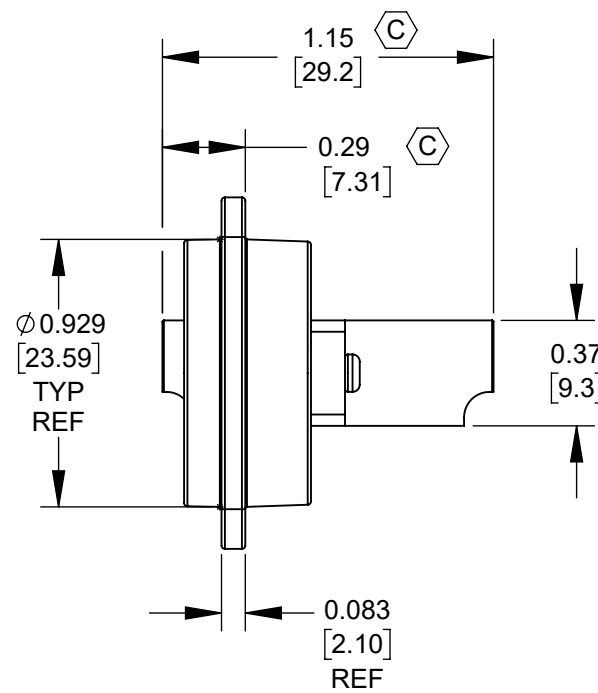
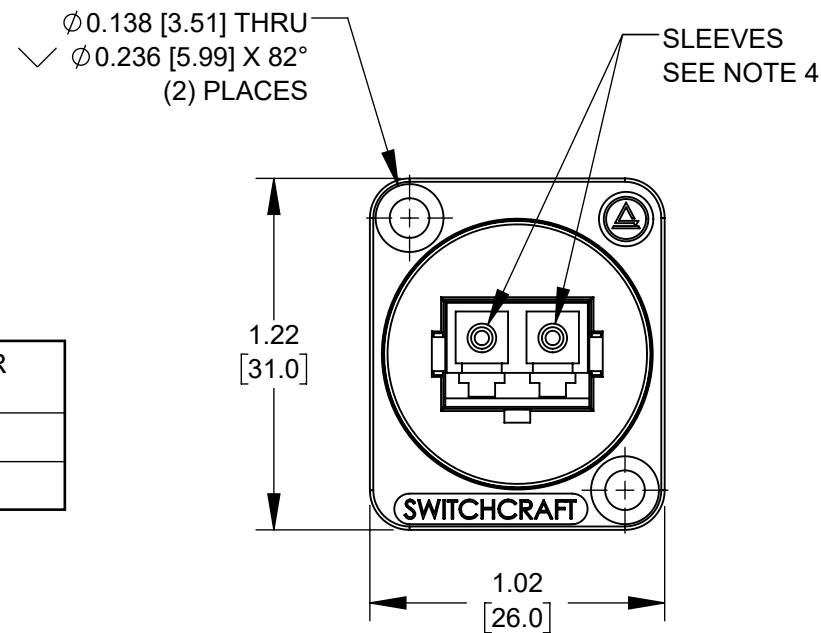

NOTES:

- INSERTION LOSS: 0.75 dB MAX.
- OPERATION TEMP: -20°C TO +70°C.
- PRODUCT COMES WITH DUST CAPS. (NOT SHOWN)
- MATERIALS:  
SLEEVE:  
SINGLE-MODE - CERAMIC (ZIRCONIA)  
MULTI-MODE - PHOSPHORUS BRONZE  
HOUSING - DELRIN, BLACK  
ADAPTER - THERMOPLASTIC  
SCREWS - STEEL, NICKEL PLATED  
ADAPTER MOUNTING CLIPS - STAINLESS STEEL
- FOR MOUNTING SCREWS TO BE SHIPPED WITH ASSEMBLY AND INDIVIDUALING PACKAGING, ADD SUFFIX -PKG TO PART NUMBER.
- WHEN MOUNTING ASSEMBLY, USE A SCREW TORQUE OF 10 INCH-POUNDS MAXIMUM.
- THIS PRODUCT IS RoHS COMPLIANT.

**CUSTOMER DRAWING**

REVISIONS					UNLESS OTHERWISE SPECIFIED					THIS DRAWING DESCRIBES A DESIGN CONSIDERED PROPRIETARY IN NATURE, DEVELOPED AND MANUFACTURED BY SWITCHCRAFT INC. AND IS RELEASED ON A CONFIDENTIAL BASIS FOR IDENTIFICATION PURPOSES ONLY.							
					1. ALL DIMENSIONS IN INCHES [mm] - TWO PLACE DECIMALS ±0.02 [0.5] - THREE PLACE DECIMALS ±0.005 [0.13]					SIZE	WIDTH	MULT	LBS/M	TEMPER			
C	28516	06/27/22	PC	TJK	DO NOT SCALE DRAWING					FINISH SPEC No.		MATERIAL SPEC No.					
B	27239	1/3/14	TO	TJK						FIRST USED ON		SCALE 1.5:1					
A	26348	2/27/09	RS	TJK						DATE DRAWN	BY	CHKD	APVD	SHEET 1 OF 1			
REV	ECO NUMBER	DATE	BY	APVD						NAME E SERIES LC TO LC FIBER OPTIC ADAPTER, RoHS		PART No.	REV				
												EHLC2_SERIES <b>C</b>					