

DO NOT SCALE FROM THIS PRINT

MRTDX-XX-XXX-X-XX.X-XX

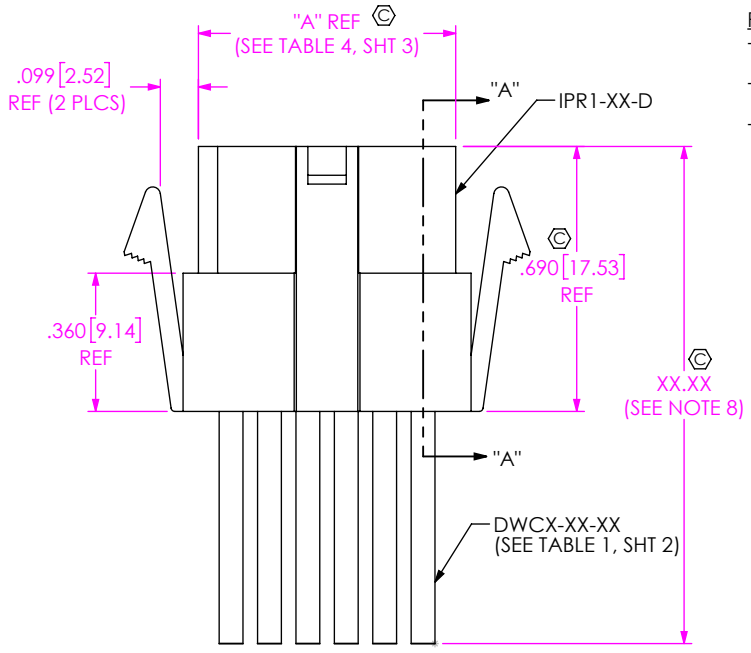
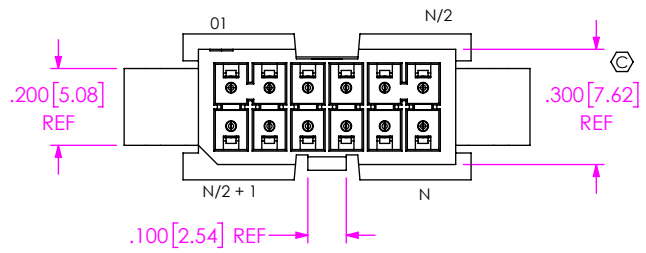
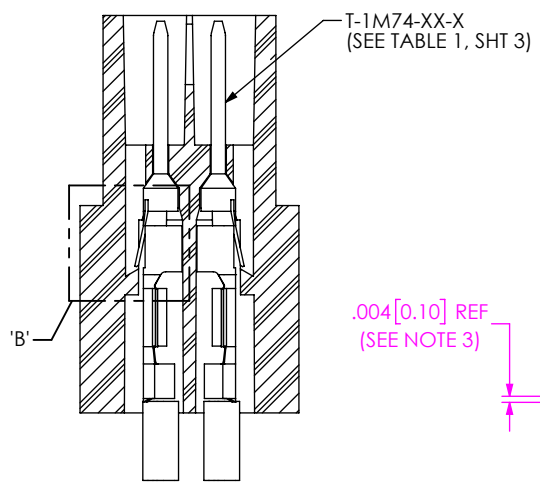
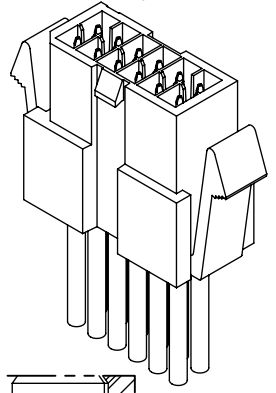
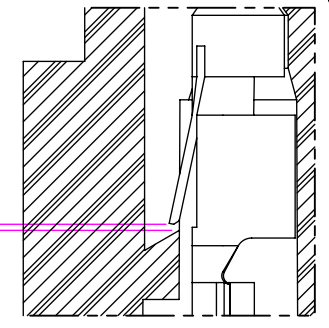

FIG 1
MRTD-06-XXX-X-XX.X SHOWN

- FEP CABLE OPTION**
-T: FEP
(LEAVE BLANK FOR STANDARD PVC INSULATION)
- No OF POSITIONS**
-02 THRU -15 (PER ROW)
- WIRE GAUGE (AWG)**
-20, -22, -24, -26, -28, -30
FEP: -20, -24, -28, -30
- COLOR CODE**
-C (SEE TABLE 2)
(LEAVE BLANK FOR STANDARD BLACK CABLE)
(NOT AVAILABLE WITH FEP OPTION)
- PLATING SPECIFICATION**
-F: 3μ" SELECTIVE GOLD IN CONTACT AREA, MATTE TIN ON TAIL
-L: 10μ" SELECTIVE GOLD IN CONTACT AREA, MATTE TIN ON TAIL
-S: 30μ" SELECTIVE GOLD IN CONTACT AREA, MATTE TIN ON TAIL
- PINOUT**
(LEAVE BLANK FOR SINGLE END ASSEMBLY)
-1: TRANSFER LATCH UP, STRAIGHT (PIN 01 TO 01, SEE FIG 2 & 4, SHT 2)
-4: TRANSFER LATCH DOWN, STRAIGHT (PIN 01 TO N, SEE FIG 3 & 5, SHT 2)
- LATCH OPTION**
(LEAVE BLANK FOR SINGLE END ASSEMBLY)
-L: PLASTIC LATCH (SEE FIG 4 & 5, SHT 2)
-M: METAL LATCH (SEE FIG 2 & 3, SHT 2)
- ASSEMBLED LENGTH**
SPECIFY IN INCHES [USE DWCX-XX-XX]
(SINGLE END: 03.0[76] INCH MINIMUM, DOUBLE END: 03.3[84] INCH MINIMUM)



SECTION "A"-"A"
SCALE 3 : 1



DETAIL 'B'
SCALE 8 : 1

NOTES:

1. Ⓢ REPRESENTS A CRITICAL DIMENSION.
2. MINIMUM PULLOUT FORCE: 0.5 lbs [2.22 N].
3. CONTACT MUST BE INSERTED UNTIL RETENTION FEATURE LOCKS INTO PLACE.
4. ALL FINISHED GOODS ARE TO BE ELECTRICAL TESTED INCLUDING HI-POT TEST @ 1000 VOLTS DC. AFTER FINAL ELECTRICAL TEST, MARK EACH ASSEMBLY PER INSTRUCTIONS REFERENCED IN CO-(AD-ID)-WI-3092-M.
5. TINNED COPPER WIRE IS ROHS COMPLIANT.
6. PARTS ARE TO BE LAYER PACKAGED.
7. REFER TO CRIMP SPECIFICATIONS PRINT FOR CRIMP AND STRIP DIMENSIONS, TOLERANCES, TOOLING AND ITS REQUIREMENTS.
8. FOR LENGTHS LESS THAN 12 IN[304.8], TOLERANCE SHALL BE ±.125[3.18]. FOR OTHER LENGTHS, TOLERANCES SHALL BE ± 2%.
9. PANEL HOLE TO BE PUNCHED OUT IN THE SAME DIRECTION AS INSERTION INTO THE PANEL.
10. CUT LENGTH IS ASSEMBLY LENGTH MINUS OVERALL LENGTH SUBTRACTOR.

<p>UNLESS OTHERWISE SPECIFIED, DIMENSIONS ARE IN INCHES. TOLERANCES ARE:</p> <p>DECIMALS ANGLES</p> <p>.XX: ±.01 [.3] 2°</p> <p>.XXX: ±.005 [.13]</p> <p>.XXXX: ±.0020 [.051]</p>	<p>PROPRIETARY NOTE</p> <p>THIS DOCUMENT CONTAINS CONFIDENTIAL AND PROPRIETARY INFORMATION AND ALL DESIGN, MANUFACTURING, REPRODUCTION, USE, PATENT RIGHTS AND SALES RIGHTS ARE EXPRESSLY RESERVED BY SAMTEC, INC. THIS DOCUMENT SHALL NOT BE DISCLOSED, IN WHOLE OR PART, TO ANY UNAUTHORIZED PERSON OR ENTITY NOR REPRODUCED, TRANSFERRED OR INCORPORATED IN ANY OTHER PROJECT IN ANY MANNER WITHOUT THE EXPRESS WRITTEN CONSENT OF SAMTEC, INC.</p>	 <p>520 PARK EAST BLVD, NEW ALBANY, IN 47150 PHONE: 812-944-6733 FAX: 812-948-5047 e-Mail: info@SAMTEC.com code: 55322</p>
<p>MATERIAL: DO NOT SCALE DRAWING</p> <p>HOUSING: NYLON 66, COLOR: WHITE</p> <p>CONTACT: PHOS BRONZE</p> <p>CABLE: INSULATION: SEE CALLOUT</p> <p>WIRE: TINNED COPPER</p>	<p>SHEET SCALE: 2:1</p>	<p>DESCRIPTION: .100[2.54] PANEL MOUNT TERMINAL CABLE ASSEMBLY</p> <p>DWG. NO. MRTDX-XX-XXX-X-XX.X-XX</p> <p>BY: JESSIE W 7/5/2013 SHEET 1 OF 4</p>

REVISION F

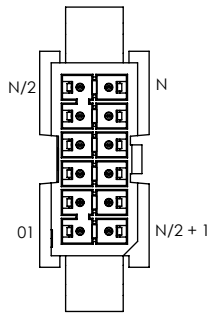

SEE TABLE 4, SHT 3

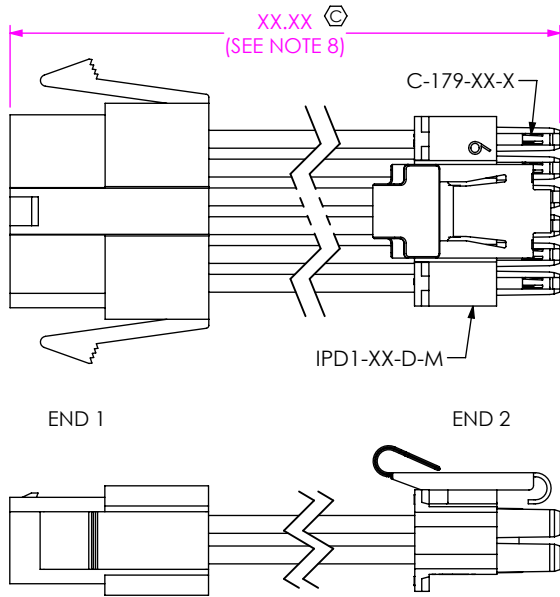
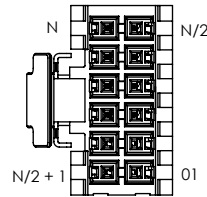
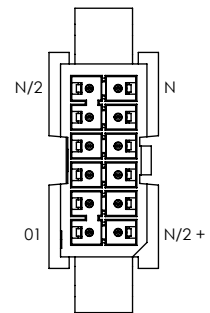

FIG 2
MRTD-06-XXX-X-XX.X-M1 SHOWN
(TRANSFER, LATCH UP, STRAIGHT)
(DIFFERENT AS SHOWN, OTHERWISE SAME AS FIG 1)



SEE TABLE 4, SHT 3



SEE TABLE 4, SHT 3

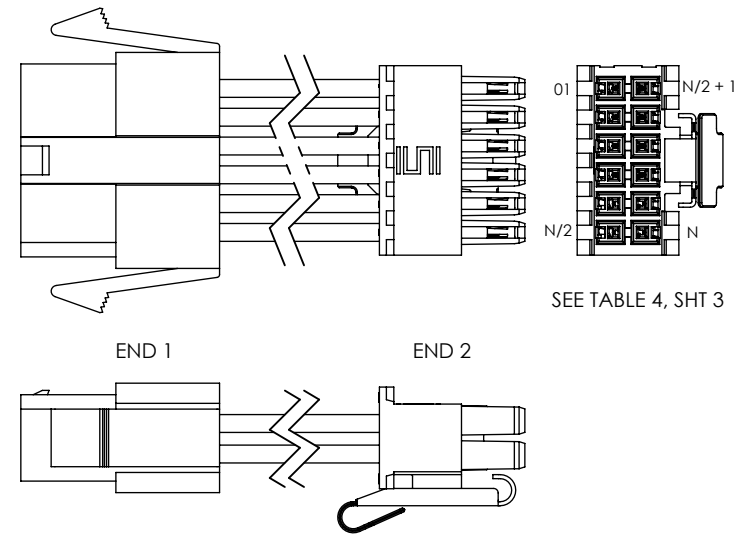
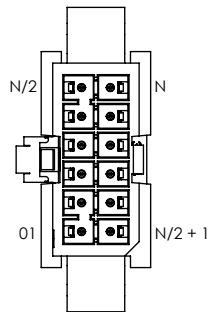

FIG 3
MRTD-06-XXX-X-XX.X-M4 SHOWN
(TRANSFER, LATCH DOWN, STRAIGHT)
(DIFFERENT AS SHOWN, OTHERWISE SAME AS FIG 2)



SEE TABLE 4, SHT 3

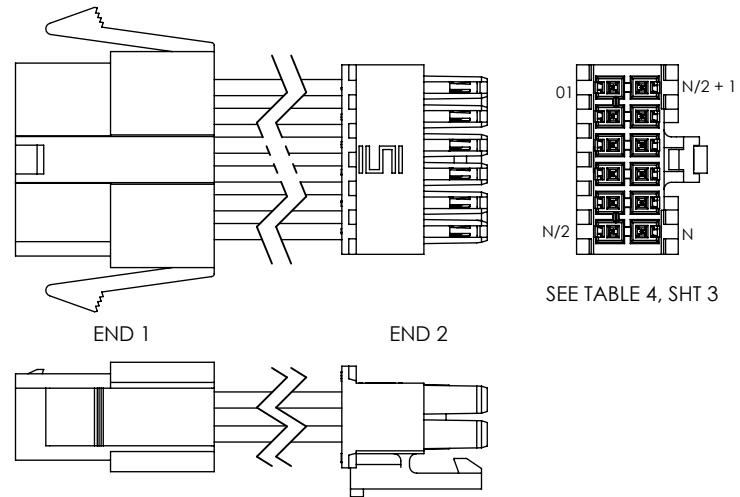
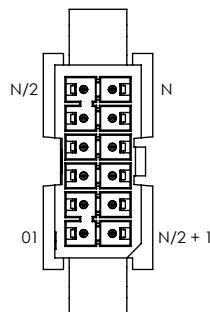

FIG 5
MRTD-06-XXX-X-XX.X-L4 SHOWN
(TRANSFER, LATCH DOWN, STRAIGHT)
(DIFFERENT AS SHOWN, OTHERWISE SAME AS FIG 4)



SEE TABLE 4, SHT 3

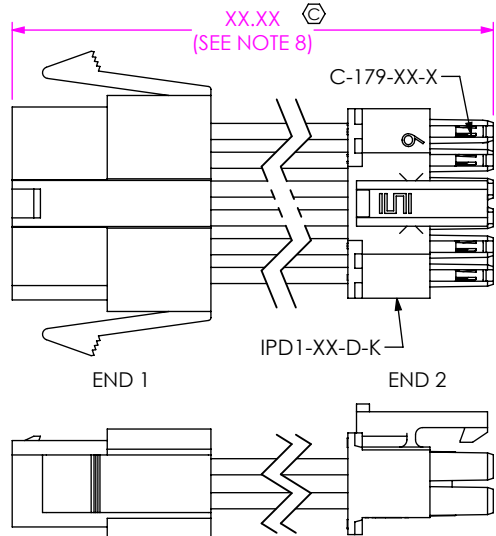
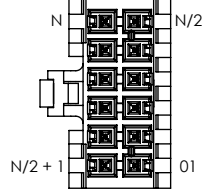

FIG 4
MRTD-06-XXX-X-XX.X-L1 SHOWN
(TRANSFER, LATCH UP, STRAIGHT)
(DIFFERENT AS SHOWN, OTHERWISE SAME AS FIG 1)



SEE TABLE 4, SHT 3

PROPRIETARY NOTE
THIS DOCUMENT CONTAINS CONFIDENTIAL AND PROPRIETARY INFORMATION AND ALL DESIGN, MANUFACTURING, REPRODUCTION, USE, PATENT RIGHTS AND SALES RIGHTS ARE EXPRESSLY RESERVED BY SAMTEC, INC. THIS DOCUMENT SHALL NOT BE DISCLOSED, IN WHOLE OR PART, TO ANY UNAUTHORIZED PERSON OR ENTITY NOR REPRODUCED, TRANSFERRED OR INCORPORATED IN ANY OTHER PROJECT IN ANY MANNER WITHOUT THE EXPRESS WRITTEN CONSENT OF SAMTEC, INC.

DO NOT SCALE DRAWING
SHEET SCALE: 3:2



520 PARK EAST BLVD, NEW ALBANY, IN 47150
PHONE: 812-944-6733 FAX: 812-948-5047
e-Mail: info@SAMTEC.com code: 55322

DESCRIPTION:
.100[2.54] PANEL MOUNT TERMINAL CABLE ASSEMBLY

DWG. NO.
MRTDX-XX-XXX-X-XX.X-XX

BY: JESSIE W 7/5/2013 SHEET 2 OF 4

GAUGE	PANEL THICKNESS	
13	0.0897	[2.278]
14	0.0747	[1.897]
15	0.0673	[1.709]
16	0.0598	[1.519]
17	0.0538	[1.367]
18	0.0478	[1.214]
19	0.0418	[1.062]
20	0.0359	[0.912]
21	0.0329	[0.836]

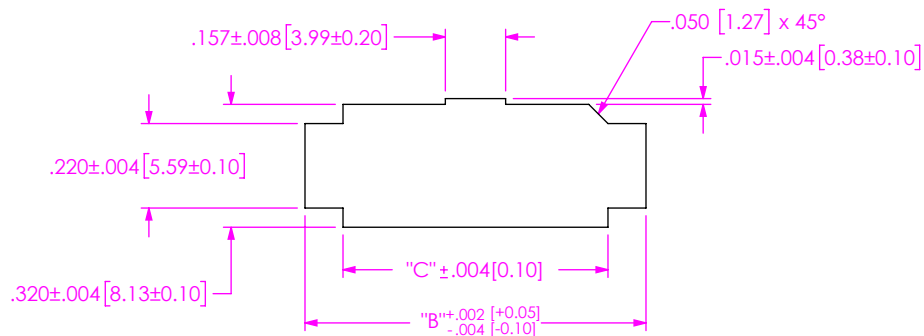

RECOMMENDED PANEL CUT OUT DIMENSIONS
THICKNESS: SEE TABLE 3
(SEE NOTE 9)

TABLE 2

MMTXX COLOR CODED WIRE SEQUENCE

PIN #	COLOR									
	BROWN	RED	ORANGE	YELLOW	GREEN	BLUE	VIOLET	GRAY	WHITE	BLACK
	DWC-XX-01-300	DWC-XX-02-300	DWC-XX-03-300	DWC-XX-04-300	DWC-XX-05-300	DWC-XX-13-300	DWC-XX-07-300	DWC-XX-08-300	DWC-XX-09-300	DWC-XX-10-300
1	2	3	4	5	6	7	8	9	10	
11	12	13	14	15	16	17	18	19	20	
21	22	23	24	25	26	27	28	29	30	
31	32	33	34	35	36	37	38	39	40	
41	42	43	44	45	46	47	48	49	50	

TABLE 4

NO OF POS	"A"	"B"	"C"	N/2	N/2 + 1	N
02	.27 [6.9]	.488 [12.40]	.290 [7.37]	2	3	4
03	.37 [9.4]	.588 [14.94]	.390 [9.91]	3	4	6
04	.47 [11.9]	.688 [17.48]	.490 [12.45]	4	5	8
05	.57 [14.5]	.788 [20.02]	.590 [14.99]	5	6	10
06	.67 [17.0]	.888 [22.56]	.690 [17.53]	6	7	12
07	.77 [19.6]	.988 [25.10]	.790 [20.07]	7	8	14
08	.87 [22.1]	1.088 [27.64]	.890 [22.61]	8	9	16
09	.97 [24.6]	1.188 [30.18]	.990 [25.15]	9	10	18
10	1.07 [27.2]	1.288 [32.72]	1.090 [27.69]	10	11	20
11	1.17 [29.7]	1.388 [35.26]	1.190 [30.23]	11	12	22
12	1.27 [32.3]	1.488 [37.80]	1.290 [32.77]	12	13	24
13	1.37 [34.8]	1.588 [40.34]	1.390 [35.31]	13	14	26
14	1.47 [37.3]	1.688 [42.88]	1.490 [37.85]	14	15	28
15	1.57 [39.9]	1.788 [45.42]	1.590 [40.39]	15	16	30

TABLE 1

SERIES	WIRE GAUGE	CABLE	TERMINAL	CONTACT
MRTD	20 AWG	DWC-20-XX-300	T-1M74-02-X	C-179-03-X
MRTD	22 AWG	DWC-22-XX-300	T-1M74-02-X	C-179-03-X
MRTD	24 AWG	DWC-24-XX-300	T-1M74-02-X	C-179-03-X
MRTD	26 AWG	DWC-26-XX-300	T-1M74-01-X	C-179-02-X
MRTD	28 AWG	DWC-28-XX-300	T-1M74-01-X	C-179-02-X
MRTD	30 AWG	DWC-30-XX-300	T-1M74-01-X	C-179-02-X
MRTDT	20AWG	DWCT-20-XX-TC	T-1M74-02-X	C-179-03-X
MRTDT	24AWG	DWCT-24-XX-TC	T-1M74-02-X	C-179-03-X
MRTDT	28AWG	DWCT-28-XX-TC	T-1M74-03-X	C-179-04-X
MRTDT	30AWG	DWCT-30-XX-TC	T-1M74-03-X	C-179-04-X

PROPRIETARY NOTE

THIS DOCUMENT CONTAINS CONFIDENTIAL AND PROPRIETARY INFORMATION AND ALL DESIGN, MANUFACTURING, REPRODUCTION, USE, PATENT RIGHTS AND SALES RIGHTS ARE EXPRESSLY RESERVED BY SAMTEC, INC. THIS DOCUMENT SHALL NOT BE DISCLOSED, IN WHOLE OR PART, TO ANY UNAUTHORIZED PERSON OR ENTITY NOR REPRODUCED, TRANSFERRED OR INCORPORATED IN ANY OTHER PROJECT IN ANY MANNER WITHOUT THE EXPRESS WRITTEN CONSENT OF SAMTEC, INC.

DO NOT SCALE DRAWING

SHEET SCALE: 2:1



520 PARK EAST BLVD, NEW ALBANY, IN 47150
PHONE: 812-944-6733 FAX: 812-948-5047
e-Mail: info@SAMTEC.com code: 55322

DESCRIPTION:
.100[2.54] PANEL MOUNT TERMINAL CABLE ASSEMBLY

DWG. NO.
MRTDX-XX-XXX-X-XX.X-XX

BY: JESSIE W 7/5/2013 SHEET 3 OF 4

CABLE CUT IN-PROCESS

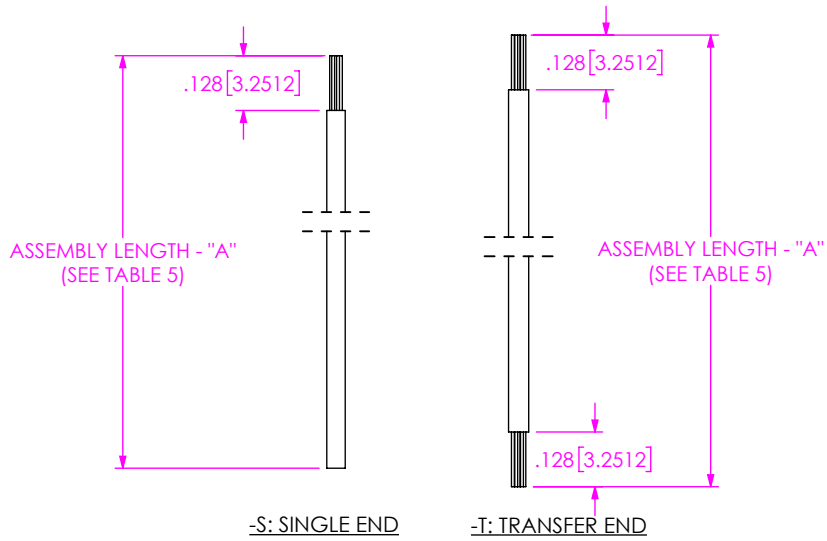

TABLE 5 (OVERALL LENGTH SUBTRACTORS) (SEE NOTE 10)	
	"A"
-S: SINGLE END	.464 [.018]
-T: TRANSFER END	.714 [.028]

PROPRIETARY NOTE
 THIS DOCUMENT CONTAINS CONFIDENTIAL AND PROPRIETARY INFORMATION AND ALL DESIGN, MANUFACTURING, REPRODUCTION, USE, PATENT RIGHTS AND SALES RIGHTS ARE EXPRESSLY RESERVED BY SAMTEC, INC. THIS DOCUMENT SHALL NOT BE DISCLOSED, IN WHOLE OR PART, TO ANY UNAUTHORIZED PERSON OR ENTITY NOR REPRODUCED, TRANSFERRED OR INCORPORATED IN ANY OTHER PROJECT IN ANY MANNER WITHOUT THE EXPRESS WRITTEN CONSENT OF SAMTEC, INC.

DO NOT SCALE DRAWING
 SHEET SCALE: 2:1



520 PARK EAST BLVD, NEW ALBANY, IN 47150
 PHONE: 812-944-6733 FAX: 812-948-5047
 e-Mail: info@SAMTEC.com code: 55322

DESCRIPTION:
 .100[2.54] PANEL MOUNT TERMINAL CABLE ASSEMBLY

DWG. NO.
 MRTDX-XX-XXX-X-XX.X-XX

BY: JESSIE W 7/5/2013 SHEET 4 OF 4