

S1D13C00

S1D13C00 Memory Display Controller

The S1D13C00 is a display controller for low-power memory displays used in wearable devices. It supports interfaces to 6-bit color memory-in-pixel (MIP) panels, 3-bit and 1-bit black-and-white panels (SPI interface), and 1/2/4/8 bpp grayscale memory LCD panels (8-bit parallel or 3/4-wire serial).

The S1D13C00 has 96Kbytes of RAM which can be used as a frame buffer and other functions. The display controller also includes a Drawing Engine and an Image/Bitmap Copying Engine with scaling and rotation or horizontal and vertical shear. A voltage booster circuit in the S1D13C00 provides two programmable supply voltages for powering the different panels supported. The S1D13C00 has built-in 32kHz, 8MHz, 12MHz, 16MHz, and 20MHz internal oscillators which supply clocks needed for operations. In addition to the display controller functions, the S1D13C00 also has other peripherals such as real-time clock/calendar (RTC), SPI, QSPI, I2C, DMA Controller, Sound Generator, and IR remote control transmitter.

The S1D13C00 has an Event Processor which has a simple instruction set for reading/writing memory and registers. For example, microcode can be written for the Event Processor to read the current time from the RTC and update the display with the current time value. The Host MCU does not need to wake up to perform this display update function.

The S1D13C00 is a flexible, low cost, low power multifunction solution that meets the display demands of wearable devices.

FEATURES

- Indirect 8-bit and Serial (SPI and QSPI) Host Interface
- Internal 96 Kbyte RAM
- Programmable resolutions and color depths (6-bit color, 3-bit color, 1-bit black-and-white, 1/2/4/8 bpp grayscale) with alpha channel
- Panel interfaces:
6-bit color, SPI (3-bit color and 1-bit black-and-white), 8-bit parallel or 3/4-wire serial (1/2/4/8 bpp grayscale)
- Memory-mapped QSPI interface for external serial Flash memory device
- SPI and I2C interfaces
- Real-Time Clock/Calendar (RTC)
- Sound Generator
- Event Processor with simple instruction set
- DMA Controller
- VDD input supply: 1.8V to 5.5V.
- Two programmable step-up voltage supplies which can operate down to VDD=2.0V (input)
- Separate I/O supply for Display Interface signals and Host Interface signals
- IR remote control transmitter which can be used for backlight intensity control
- Built-in 32kHz and 8/12/16/20MHz oscillators.
- Temperature range: -40°~ 85°C
- Package: WCSP-64, TQFP13-64
- Low-Power Consumption:
 - All stop:400nA(TBD)

SYSTEM BLOCK DIAGRAM

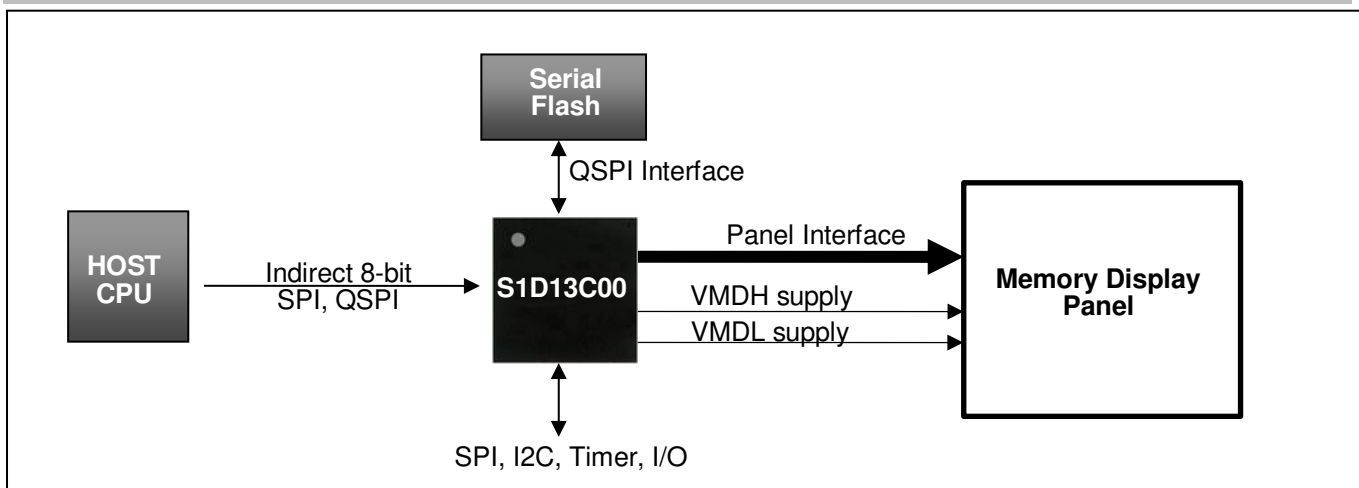

DESCRIPTION

Host Interface

- Indirect 8-bit parallel interface
- SPI (Mode0 or Mode3)
- QSPI (Mode0 or Mode3)

Display Memory

- 96 Kbyte internal RAM

Display Support

- 6-bit color memory-in-pixel display
- 3-bit color and 1-bit black-and-white memory LCD with SPI interface
- 1/2/4/8 bpp grayscale LCD with 8-bit parallel or 3/4-wire serial interface
- 0°,90°,180°,270° rotation from frame buffer to panel

Display Features

- Drawing functions: line, rectangle, ellipse
- Image/bitmap copying with scaling & rotation or horizontal & vertical shearing
- Alpha channel for 6-bit color, 3-bit color, 1-bit black-and-white, and 1/2/4/8 bpp grayscale formats
- Source image/bitmap for copying functions can be from memory-mapped external QSPI serial Flash memory device

Voltage Booster Supplies

- VMDL: 2.30V, 2.70V, 3.00V, 3.10V, 3.20V, 3.30V, 3.40V, or 3.60V selectable
- VMDH: 4.30V, 4.40V, 4.50V, 4.60V, 4.70V, 4.80V, 4.90V, or 5.00V selectable

Miscellaneous

- Memory Display Controller (MDC) with drawing and image copying functions
- Event Processor with simple instruction set
- Real-time clock/calendar (RTC)
- SPI master/slave interface
- I2C master/slave interface
- QSPI master/slave interface with memory-mapped read access to external serial flash
- DMA controller
- 16-bit general-purpose timers
- General-purpose I/O pins
- 32kHz internal oscillator or 32.768kHz external crystal circuit
- 8/12/16/20MHz internal oscillator
- Operating Temperature: -40 to 85 °C
- Packages:
 - TQFP13-64
 - WCSP-64

For more information on the S1D13C00 and other Epson Display Controllers, visit the Epson Global website.

https://global.epson.com/products_and_drivers/semicon/products/display_controllers/



For Sales and Technical Support, contact the Epson representative for your region.

https://global.epson.com/products_and_drivers/semicon/information/support.html



NOTICE:

Document code: XB8A-C-001-01.1

No part of this material may be reproduced or duplicated in any form or by any means without the written permission of Seiko Epson. Seiko Epson reserves the right to make changes to this material without notice. Seiko Epson does not assume any liability of any kind arising out of any inaccuracies contained in this material or due to its application or use in any product or circuit and, further, there is no representation that this material is applicable to products requiring high level reliability, such as, medical products. Moreover, no license to any intellectual property rights is granted by implication or otherwise, and there is no representation or warranty that anything made in accordance with this material will be free from any patent or copyright infringement of a third party. When exporting the products or technology described in this material, you should comply with the applicable export control laws and regulations and follow the procedures required by such laws and regulations. You are requested not to use, to resell, to export and/or to otherwise dispose of the products (and any technical information furnished, if any) for the development and/or manufacture of weapon of mass destruction or for other military purposes.

All brands or product names mentioned herein are trademarks and/or registered trademarks of their respective companies.

©Seiko Epson Corporation 2018. All rights reserved.