

NOTES:

1. MATERIALS AND FINISHES:
 BODY, BULLET CONTACT, SLEEVE, INNER FERRULE,
 HEX NUT & LOCK WASHER - BRASS, GOLD PLATING
 CONTACT - BeCu, GOLD PLATING
 INSULATOR & INSULATOR DISC - PTFE, NATURAL
 GASKET - SILICONE RUBBER, RED
2. ELECTRICAL:
 A. IMPEDANCE: 50 OHM
 B. FREQUENCY: DC - 6 GHz
 C. VSWR: 1.30 MAX. DC - 3 GHz
 1.40 MAX. 3 - 6 GHz
 D. DIELECTRIC WITHSTANDING VOLTAGE: 500 VRMS, MIN.
3. MECHANICAL:
 A. DURABILITY: 500 CYCLES MIN.
 B. TEMPERATURE RANGE: -65°C TO +165°C

4. PACKAGING:
 A. QUANTITY: SINGLE PACK
 B. MARKING: PACKAGING TO BE MARKED
 "AMPHENOL RF, 901-10753 & DATE CODE"
5. CABLE ASSEMBLY INSTRUCTIONS:
 A. TRIM CABLE AS SHOWN.
 B. INSERT CABLE THROUGH INNER FERRULE AND PEEL BRAID BACK,
 OVER INNER FERRULE.
 C. INSTALL SLEEVE AND INSULATOR DISC OVER CABLE, BOTTOMING ON
 INNER FERRULE.
 D. SOLDER BULLET CONTACT TO CABLE CENTER CONDUCTOR,
 BOTTOMING ON INSULATOR DISC.
 E. INSERT CABLE INTO CONNECTOR UNTIL IT BOTTOMS.
 F. CRIMP BODY OVER INNER FERRULE USING 0.105" HEX.

6 SHOWS CABLE ENTRY DIMENSIONS.

REVISIONS				
REV	DESCRIPTION	DATE	ECN	BY
A	RELEASE TO MFG	08-NOV-21	15935	SH

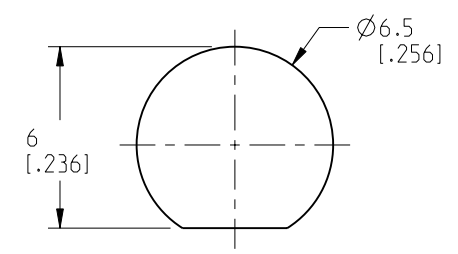

RECOMMENDED MOUNTING HOLE DIMENSIONS

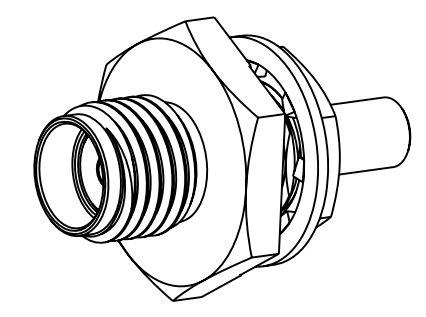

SCALE 3.000

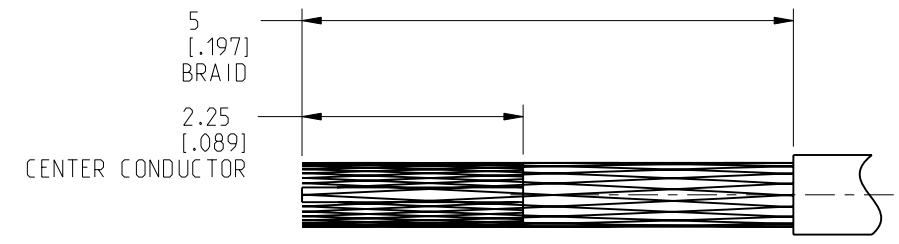

RECOMMENDED CABLE STRIPPING DIMENSIONS

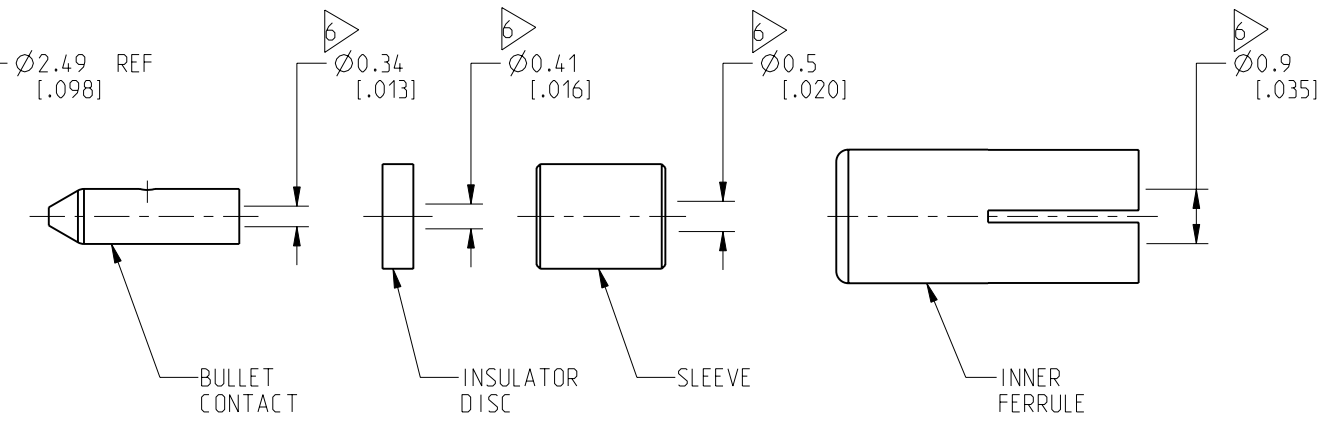
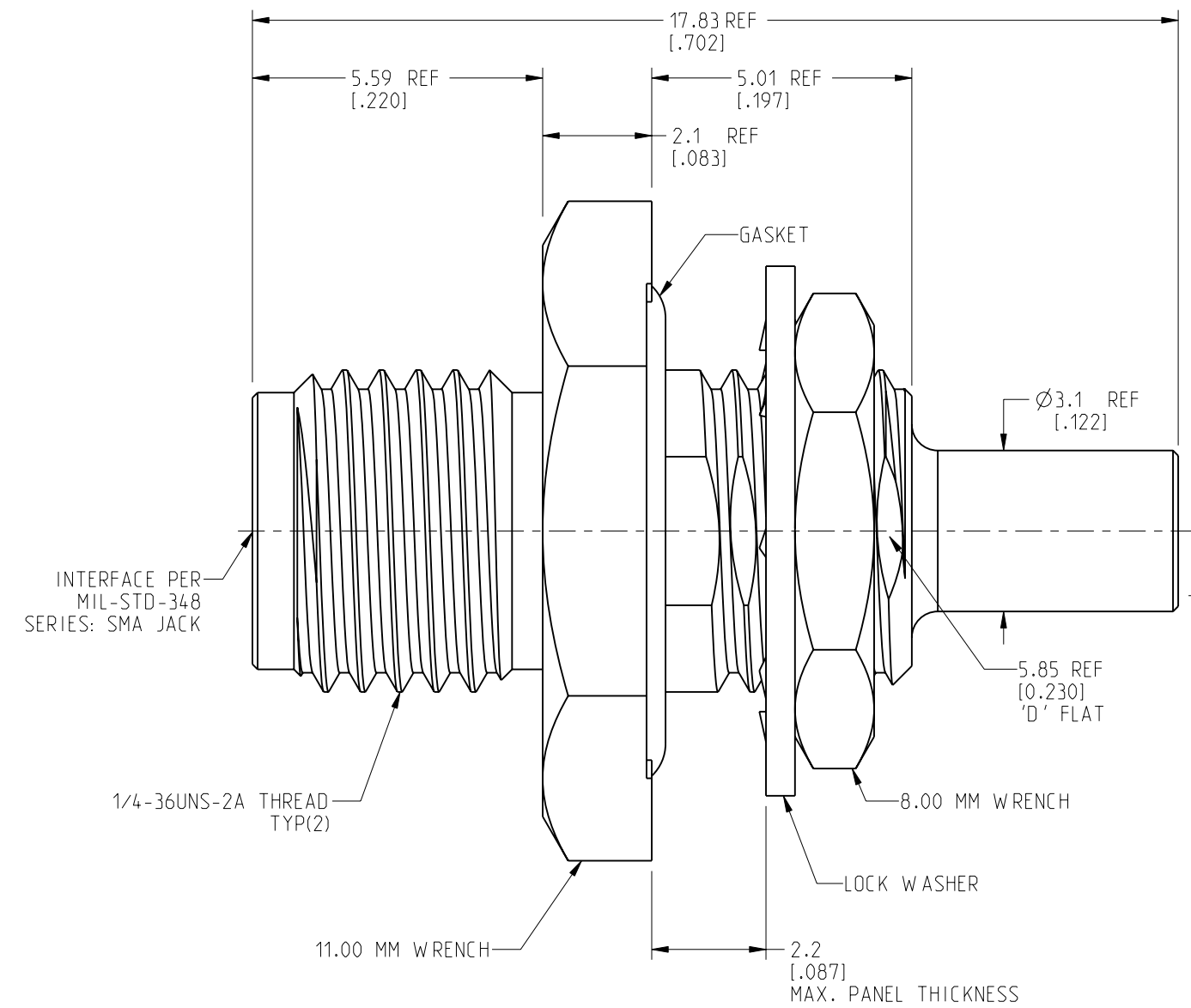

CUSTOMER OUTLINE DRAWING
ALL OTHER SHEETS ARE FOR INTERNAL USE ONLY

NOTICE: These drawings, specifications, or other data (1) are, and remain the property of Amphenol corp. (2) must be returned upon request; and (3) are confidential and not to be disclosed to any person other than those to whom they are given by Amphenol Corp. The furnishing of these drawings, specifications, or other data by Amphenol Corp., or to any other person to anyone for any purpose is not to be regarded by implication or otherwise in any manner licensing, granting rights to permitting such holder or any other person to manufacture, use or sell any product, process or design, patented or otherwise, that may in any way be related to or disclosed by said drawings, specifications, or other data.

THIRD ANGLE PROJ. REFERENCE EAR# 10133

UNLESS OTHERWISE SPECIFIED DIMENSIONS ARE METRIC (INCHES) AND TOLERANCES ARE:
 <0.5mm = ±0.05mm [-0.020 = ±0.002]
 >0.5 - 6mm = ±0.1mm [-0.020 - 0.236 = ±0.004]
 >6.00 - 30mm = ±0.2mm [-0.236 - 1.181 = ±0.008]
 >30.00 - 120mm = ±0.3mm [-1.181 - 4.725 = ±0.012]

ANGLES = ±1°

MATERIAL SEE NOTES

ENGR.1 C.CROTTY ENGR.2 E.WU DATE 04-OCT-21

TITLE SMA STR BHD JACK FRONT MOUNT FOR 0.81 MM CABLE

SHEET NO. 2 OF 2 SCALE: 8.0:1.0

SIZE B		DRAWING NO. 901-10753		REV A
		ITEM NO. 901-10753		
		PART NO. 901-10753		