

10 9 8 7 6 5 4 3 2 1

F  
E  
D  
C  
B  
A

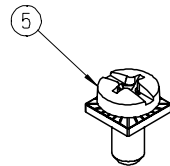

REF. -50 OPT. SCREW  
(WHERE APPLICABLE)

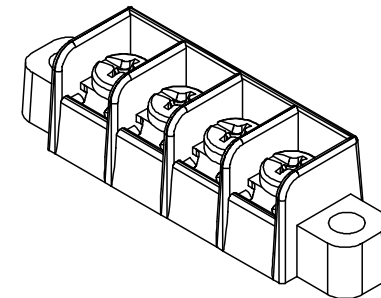
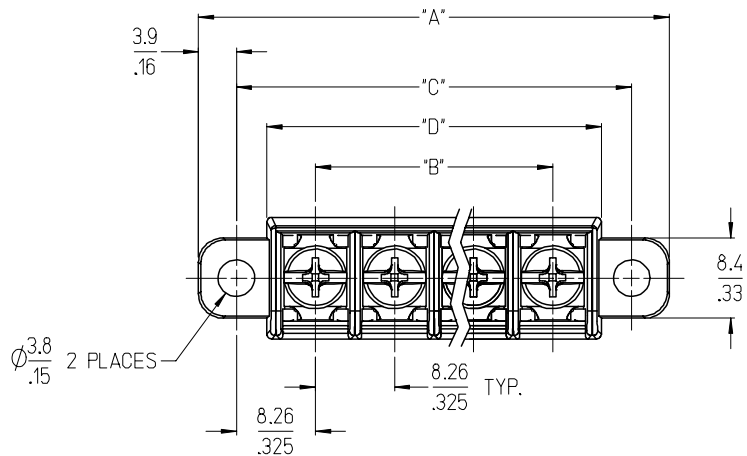

4 CIRCUIT SHOWN

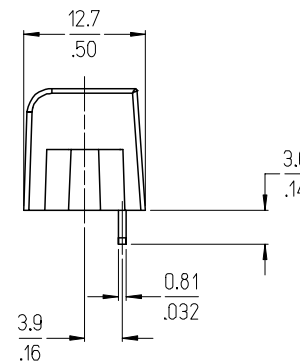
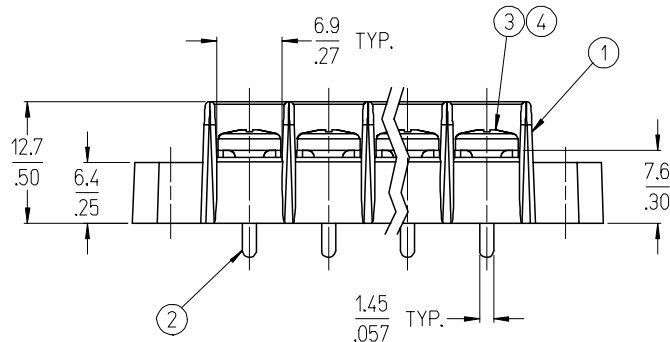

NOTES:

- 1. MATERIAL: SEE TABLE
- 2. FINISH: SEE TABLE
- 3. "XX" REFERS TO THE QUANTITY OF CIRCUITS.
- 4. ASSEMBLY IS ROHS COMPLIANT.

5	XX	SCREW&WASHER, #6-32X.25, PAN, PH/SL (-50 OPT)	STEEL	ZN, CLEAR CHROMATE
4	XX	SCREW, #6-32X.25, PAN, PH/SL (-49 OPT)	BRASS	NICKEL PLATE
3	XX	SCREW, #6-32X.25, PAN, PH/SL (STD.)	STEEL	ZN, CLEAR CHROMATE
2	XX	TERMINAL, PC	BRASS	TIN PLATE
1	1	INSULATOR, SR, CS, PC	PBT	BLACK
ITEM	QTY.	DESCRIPTION	MATERIAL	FINISH

INITIAL RELEASE  
EC NO: ETC2007-0160  
DRAWN: CLYORK 2006/11/20  
CHKD: JMACNEIL 2006/11/21  
APPR: JMACNEIL 2006/11/22

QUALITY SYMBOLS  
▽=0  
▽=0

GENERAL TOLERANCES (UNLESS SPECIFIED)	
4 PLACES	± --- ± ---
3 PLACES	± --- ± .005
2 PLACES	± 0.13 ± .01
1 PLACE	± 0.3 ± ---
ANGULAR ± 2 °	
DRAFT WHERE APPLICABLE MUST REMAIN WITHIN DIMENSIONS	

DIMENSION STYLE	
MM/IN	
DRAWN BY	DATE
C. YORK	2006/11/08
CHECKED BY	DATE
J. MACNEIL	2006/11/08
APPROVED BY	DATE
J. MACNEIL	2006/11/08
MATERIAL NO.	
SEE SHT. 2	

SCALE	DESIGN UNITS	THIRD ANGLE PROJECTION
2:1	INCH	
TITLE		
8.26MM [.325] SR BTS, CS PC WITH MTG.		
MATERIAL NO.		
SEE SHT. 2		
DOCUMENT NO.		
SD-38704-003		
SHEET NO.		
1 OF 2		

THIS DRAWING CONTAINS INFORMATION THAT IS PROPRIETARY TO MOLEX INCORPORATED AND SHOULD NOT BE USED WITHOUT WRITTEN PERMISSION

9 8 7 6 5 4 3 2 1

10 9 8 7 6 5 4 3 2 1

NO. OF CIRCUITS	DIM. "A"		DIM. "B"		DIM. "C"		DIM. "D"		ASSEMBLY MATERIAL NO. (STANDARD)	ASSEMBLY MATERIAL NO. (-49 OPT)	ASSEMBLY MATERIAL NO. (-50 OPT)
	mm	in	mm	in	mm	in	mm	in			
02	32.6	1.29	8.26	.325	24.77	.975	18.4	.73	387044002	387044402	387044802
03	40.9	1.61	16.51	.650	33.02	1.300	26.7	1.05	387044003	387044403	387044803
04	49.1	1.94	24.77	.975	41.28	1.625	34.9	1.38	387044004	387044404	387044804
05	57.4	2.26	33.02	1.300	49.53	1.950	43.2	1.70	387044005	387044405	387044805
06	65.7	2.59	41.28	1.625	57.79	2.275	51.4	2.03	387044006	387044406	387044806
07	73.9	2.91	49.53	1.950	66.04	2.600	59.7	2.35	387044007	387044407	387044807
08	82.2	3.24	57.79	2.275	74.30	2.925	67.9	2.68	387044008	387044408	387044808
09	90.4	3.56	66.04	2.600	82.55	3.250	76.2	3.00	387044009	387044409	387044809
10	98.7	3.89	74.30	2.925	90.81	3.575	84.5	3.33	387044010	387044410	387044810
11	106.9	4.21	82.55	3.250	99.06	3.900	92.7	3.65	387044011	387044411	387044811
12	115.2	4.54	90.81	3.575	107.32	4.225	101.0	3.98	387044012	387044412	387044812

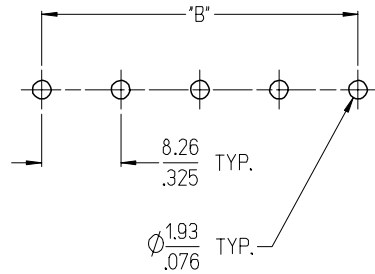

RECOMMENDED PCB LAYOUT

SEE SHEET 1	EC NO: ETC2007-0160 DRWN: CLYORK 2006/11/20 CHKD: JMACNEIL 2006/11/21 APPR: JMACNEIL 2006/11/22	DESCRIPTION	QUALITY SYMBOLS	GENERAL TOLERANCES (UNLESS SPECIFIED)	DIMENSION STYLE	SCALE	DESIGN UNITS	THIRD ANGLE PROJECTION															
			$\nabla=0$ $\nabla=0$	<table border="1"> <tr><th></th><th>mm</th><th>INCH</th></tr> <tr><td>4 PLACES</td><td>± ---</td><td>± ---</td></tr> <tr><td>3 PLACES</td><td>± ---</td><td>± .005</td></tr> <tr><td>2 PLACES</td><td>± 0.13</td><td>± .01</td></tr> <tr><td>1 PLACE</td><td>± 0.3</td><td>± ---</td></tr> </table>		mm	INCH	4 PLACES	± ---	± ---	3 PLACES	± ---	± .005	2 PLACES	± 0.13	± .01	1 PLACE	± 0.3	± ---	MM/IN	2:1	INCH	<input checked="" type="checkbox"/>
				mm	INCH																		
			4 PLACES	± ---	± ---																		
3 PLACES	± ---	± .005																					
2 PLACES	± 0.13	± .01																					
1 PLACE	± 0.3	± ---																					
<table border="1"> <tr><td>DRAWN BY</td><td>DATE</td></tr> <tr><td>C. YORK</td><td>2006/11/08</td></tr> <tr><td>CHECKED BY</td><td>DATE</td></tr> <tr><td>J. MACNEIL</td><td>2006/11/08</td></tr> <tr><td>APPROVED BY</td><td>DATE</td></tr> <tr><td>J. MACNEIL</td><td>2006/11/08</td></tr> </table>	DRAWN BY	DATE	C. YORK	2006/11/08	CHECKED BY	DATE	J. MACNEIL	2006/11/08	APPROVED BY	DATE	J. MACNEIL	2006/11/08	TITLE		8.26MM [.325] SR BTS, CS PC WITH MTG.								
DRAWN BY	DATE																						
C. YORK	2006/11/08																						
CHECKED BY	DATE																						
J. MACNEIL	2006/11/08																						
APPROVED BY	DATE																						
J. MACNEIL	2006/11/08																						
<table border="1"> <tr><td>MATERIAL NO.</td><td>DOCUMENT NO.</td><td>SHEET NO.</td></tr> <tr><td>SEE CHART</td><td>SD-38704-003</td><td>2 OF 2</td></tr> </table>	MATERIAL NO.	DOCUMENT NO.	SHEET NO.	SEE CHART	SD-38704-003	2 OF 2	DRAFT WHERE APPLICABLE MUST REMAIN WITHIN DIMENSIONS		MOLEX INCORPORATED														
MATERIAL NO.	DOCUMENT NO.	SHEET NO.																					
SEE CHART	SD-38704-003	2 OF 2																					

9 8 7 6 5 4 3 2 1

THIS DRAWING CONTAINS INFORMATION THAT IS PROPRIETARY TO MOLEX INCORPORATED AND SHOULD NOT BE USED WITHOUT WRITTEN PERMISSION