

### PRODUCT OVERVIEW

The D1U86P-W-2200-12-HBxDC are highly efficient 2,226 watt, power factor corrected front end power supplies that provide a 12V Main and a 12V standby output. Multiple units can current share and be operated in parallel. The power supplies may be hot plugged and are protected from fault conditions such as overtemperature, overcurrent and overvoltage. Status is indicated by a front mounted multi-function LED in addition to logic signaling and may be monitored via PMBus™. The low profile 1U package and >52 W/cubic inch power density make them ideal for delivering reliable, efficient power to servers, workstations, storage systems and other 12V distributed power systems, whilst minimizing the number of required power modules.



### ORDERING GUIDE

Part Number	Main Power Output vs. AC Line			Output	Standby Output	Airflow
	100-110V <sub>AC</sub>	120V <sub>AC</sub>	200-240V <sub>AC</sub>			
D1U86P-W-2200-12-HB3DC	1000W	1150W	2200W	12V	12V	Front to Back
D1U86P-W-2200-12-HB4DC <sup>1</sup>						Back to Front

<sup>1</sup> Please contact Murata for availability

### FEATURES

- 2226W total output power
- >94% minimum efficiency at 50% load
- 12V main output
- 12V 30W standby output
- 1U height: 3.4" x 7.78" x 1.59" (86.4mm x 197.7mm x 40.5mm)
- >52 Watts per cubic inch density
- N+1 redundancy, including hot plugging
- Droop current sharing with internal ORing /isolation circuit, both outputs
- Overvoltage, overcurrent, overtemperature protection
- Internal cooling fan (variable speed)
- PMBus™/I2C interfaces monitoring and control
- RoHS compliant
- Two Year Warranty

### INPUT CHARACTERISTICS

Parameter	Conditions	Min.	Nom.	Max.	Units
Input Voltage Operating Range		90	115/230	264	V <sub>AC</sub>
Frequency		47	50/60	63	Hz
Turn-on Voltage	Ramp up	81		89	V <sub>AC</sub>
Turn-off Voltage	Ramp down	70.5	73	78	V <sub>AC</sub>
Maximum Input Current	100-110V, 120V, 200-240V			12.0	Arms
Inrush Current	At 264V <sub>AC</sub> at 25°C cold start			50	Apk
Power Factor	At 230V <sub>AC</sub> , half load		0.98		
Efficiency (230V <sub>AC</sub> ) excluding fan load	20% load	90			%
	50% load	94			%
	100% load	91			%

Note: Front-Back variant 80+ certified

### OUTPUT VOLTAGE CHARACTERISTICS

Output Voltage	Parameter	Conditions	Min.	Typ.	Max.	Units
12V	Voltage Set Point	50% load	12.17	12.20	12.23	V <sub>DC</sub>
	Line and Load Regulation		11.60		12.80	
	Ripple Voltage & Noise <sup>1</sup>	20MHz Bandwidth			120	mV p-p
	Output Current (230 V <sub>AC</sub> )		0		183	A
	Output Current (120 V <sub>AC</sub> )		0		95	A
	Output Current (100 V <sub>AC</sub> )		0		83	A
	Load Capacitance				10,000	μF
12VSB	Voltage Set Point	50% load	11.97	12.0	12.02	V <sub>DC</sub>
	Ripple Voltage & Noise <sup>1</sup>	20MHz Bandwidth			120	mV p-p
	Output Current	100-240V <sub>AC</sub>	0		2.5	A

<sup>1</sup>Ripple and noise measured with a parallel combination of a 1.0μF ceramic and 10μF tantalum capacitor on each of the power module outputs. A short coaxial cable connected directly to the input of a scope is required.



Available now at:  
[www.murata-ps.com/en/3d/acdc.html](http://www.murata-ps.com/en/3d/acdc.html)

For full details go to  
[www.murata-ps.com/rohs](http://www.murata-ps.com/rohs)



Test Certificate and Test Report

[www.murata-ps.com/support](http://www.murata-ps.com/support)

**OUTPUT CHARACTERISTICS**

Parameter	Conditions	Min.	Typ.	Max.	Units
Output Rise Monotonicity	No voltage excursion; linear slope				
Startup Time	AC ramp up		1.5	3	s
Transient Response	12V, 50% load step, 1.0A $\mu$ s di/dt, 5A min. load		$\pm$ 600		mV
	12VSB, 50% load step, 1.0A $\mu$ s di/dt		$\pm$ 600		
Current sharing accuracy	At 100% load			$\pm$ 7	%
Hot Swap Transients	All outputs remain in regulation			5	%
Holdup Time	At full load	12			ms

**ENVIRONMENTAL CHARACTERISTICS**

Parameter	Conditions	Min.	Typ.	Max.	Units
Storage Temperature Range		-40		70	°C
Operating Temperature Range		0		50	
Operating Humidity	Noncondensing	5		90	%
Storage Humidity		5		95	
Altitude (without derating at 45°C)		3000			m
Shock	30G non-operating				
Vibration	10-500Hz, 0.5G (non-operational)				
MTBF (Target)	Per Telcordia SR-322 M1C1 @ 40°C	559K			hrs
Acoustic				65	dB(A)/@1m
Safety Approvals	CAN/CSA C22.2 No 60950-1-07, Am.1:2011, Am 2:2014 ANSI/UL 60950-1-2014 IEC60950-1:2005 (2nd Ed.), Am 1:2009 + Am 2:2013 EN 60950-1:2006+A11:2009 +A1:2010 +A12:2011 +A2:2013 CQC GB4943.1-2011; GB9254-1-2008; GB17625, 1-2012				
Input Fuse	Power Supply has internal 16A/250V fast blow fuse on the AC line input.				
Weight				2.54/1.15	lbs/Kg

**PROTECTION CHARACTERISTICS**

Output Voltage	Parameter	Conditions	Min.	Typ.	Max.	Units
	Overtemperature (intake) – to be verified	An OTP warning shall be issued via the PMBus™ interface when the air inlet exceeds 60°C; however the power module shall not shut down until critical internal hotspot temperatures are exceeded.		60		°C
12V	Overvoltage	Latching	13.2		14.4	V
	Overcurrent at 230V <sub>AC</sub>	Shutdown of the output followed by auto- recovery after one second. The output shall attempt three such auto-recovery attempts and then enter a permanent latched state. Recovery of the permanent latched state shall require cycling of the incoming AC source or toggling of the PSON# signal.	192		210	A
	Overcurrent at 108 - 120V <sub>AC</sub>		100		115	
	Overcurrent at 90 - 108V <sub>AC</sub>		87		96	
12VSB	Overvoltage	Latching	13.2		14.4	V
	Overcurrent	Auto-recovery	2.75		3.3	A

### ISOLATION CHARACTERISTICS

Parameter	Conditions	Min.	Typ.	Max.	Units
Insulation Safety Rating / Test Voltage	Input to Output - Reinforced	3000			Vrms
	Input to Chassis - Basic	1500			Vrms
Isolation	Output to Chassis	500			V <sub>DC</sub>
Leakage Current	1.5mA at 264V <sub>AC</sub> , 50/60Hz				

### EMISSIONS AND IMMUNITY

Characteristic	Standard	Compliance & Conditions
Input Current Harmonics	IEC/EN 61000-3-2	Complies
Voltage Fluctuation and Flicker	IEC/EN 61000-3-3	Complies
Conducted Emissions	FCC 47 CFR Part 15/CISPR 22/EN55022	Class A, 6dB margin
ESD Immunity	IEC/EN 61000-4-2	Level 3 criteria A
Radiated Field Immunity	IEC/EN 61000-4-3	Level 3 criteria B
Electrical Fast Transient Immunity	IEC/EN 61000-4-4	Level 3 criteria A; 2kV, 12V Main load 48A, 12V standby load 1.2A
Surge Immunity	IEC/EN 61000-4-5	Level 3 criteria A: <sup>1</sup> CM: 2kV, 2ohm line impedance, 50A load main output, 1.2A Standby load <sup>1</sup> DM: 1kV 2 ohm line impedance, 50A load main output, 1.2A Standby load
Radiated Field Conducted Immunity	IEC/EN 61000-4-6	Level 3 criteria A
Magnetic Field Immunity	IEC/EN 61000-4-8	3 A/m criteria A
Voltage dips, interruptions	IEC/EN 61000-4-11	230Vin, 100% load, Phase 0°, Dip 100% Duration 10ms (A) 230Vin, 50% load, Phase 0°, Dip 100% Duration 20ms (VSB:A, V1:A) 230Vin, 100% load, Phase 0°, Dip 100% Duration > 20ms (VSB, V1:B)

<sup>1</sup> Impedance is 2 ohms for ±2kV common mode and ±1kV differential model to comply with Nebs GR-1089 limits, Maximum load capacitance is required for these tests.

### STATUS AND CONTROL SIGNALS

Signal Name	I/O	Description	Interface Details																																															
<a href="#">PSOK (Output OK)</a>	Output	<p>The <a href="#">PSOK output</a> is a logical “OR” of three internal signals; however the output is not strictly a “digital” signal that transitions between “low” and “high” but is analogue in nature. The internal logic signals are as follows:</p> <ol style="list-style-type: none"> <li>AC_OK_H</li> <li>PWR_GOOD_H</li> <li>FAULT_L</li> </ol> <p>The following is a “truth table” that shows the analogue levels of operation of the signal dependent upon the three internal logic signals:</p> <table border="1"> <thead> <tr> <th colspan="6">PSOK TRUTH TABLE VS. ANALOG OUTPUT</th> </tr> <tr> <th colspan="3">INTERNAL LOGIC SIGNALS</th> <th colspan="2">PSOK</th> <th rowspan="2">OPERATION MODE</th> </tr> <tr> <th>AC_OK_H</th> <th>PWR_GOOD_H</th> <th>FAULT_L</th> <th>LEVEL</th> <th>LIMITS (V<sub>DC</sub>)</th> </tr> </thead> <tbody> <tr> <td>0</td> <td>0</td> <td>1</td> <td>≤ 0.6V<sub>DC</sub></td> <td>0 to 0.6</td> <td>Off</td> </tr> <tr> <td>0</td> <td>1</td> <td>1</td> <td>(1/3)</td> <td>1.030 -</td> <td>Power Off</td> </tr> <tr> <td>1</td> <td>0</td> <td>1</td> <td>(2/3)</td> <td>2.127 –</td> <td>Standby</td> </tr> <tr> <td>1</td> <td>1</td> <td>1</td> <td>VDD<sup>1</sup></td> <td>3.186 –</td> <td>Power Good</td> </tr> <tr> <td>X</td> <td>X</td> <td>0</td> <td>≤ 0.6V<sub>DC</sub></td> <td>0 to 0.6</td> <td>PS Fault</td> </tr> </tbody> </table> <p><sup>1</sup> VDD = 3.3V<sub>DC</sub></p> <p>The timing relationship of this signal is shown in the <a href="#">Timing Specification section</a> that follows.</p>	PSOK TRUTH TABLE VS. ANALOG OUTPUT						INTERNAL LOGIC SIGNALS			PSOK		OPERATION MODE	AC_OK_H	PWR_GOOD_H	FAULT_L	LEVEL	LIMITS (V <sub>DC</sub> )	0	0	1	≤ 0.6V <sub>DC</sub>	0 to 0.6	Off	0	1	1	(1/3)	1.030 -	Power Off	1	0	1	(2/3)	2.127 –	Standby	1	1	1	VDD <sup>1</sup>	3.186 –	Power Good	X	X	0	≤ 0.6V <sub>DC</sub>	0 to 0.6	PS Fault	<p>The PSOK Signal is provided with a buffered output that is driven from a DAC within the secondary microprocessor.</p> <p>The output impedance is 1K15 ohms</p>
		PSOK TRUTH TABLE VS. ANALOG OUTPUT																																																
INTERNAL LOGIC SIGNALS			PSOK		OPERATION MODE																																													
AC_OK_H	PWR_GOOD_H	FAULT_L	LEVEL	LIMITS (V <sub>DC</sub> )																																														
0	0	1	≤ 0.6V <sub>DC</sub>	0 to 0.6	Off																																													
0	1	1	(1/3)	1.030 -	Power Off																																													
1	0	1	(2/3)	2.127 –	Standby																																													
1	1	1	VDD <sup>1</sup>	3.186 –	Power Good																																													
X	X	0	≤ 0.6V <sub>DC</sub>	0 to 0.6	PS Fault																																													

### STATUS AND CONTROL SIGNALS cont'd

Signal Name	I/O	Description	Interface Details
PS_INTERRUPT (FAULT/WARNING)	<a href="#">Output</a>	The signal output is driven low to indicate that the power supply has detected a warning or fault and is intended to alert the system. This output must be driven high when the power is operating correctly (within specified limits). The signal will revert to a high level when the warning/fault stimulus (that caused the alert) is removed.	Pulled up internally via 10K to 3.3V <sub>DC</sub> . A logic high >2.0V <sub>DC</sub> A logic low <0.8V <sub>DC</sub> Driven low by internal buffer (open drain output).
PRESENT#	<a href="#">Output</a>	Based on the industry standard Common Slot requirement this signal is used to detect the presence of an (installed) power module within the host system. However it is also intended to “Enable” the Main 12V <sub>DC</sub> output. The signal is also designed to control the power module during hot plug insertion/extraction in conjunction with the host system and is provided on a short “last to make; first to break” signal pin. To “enable” the Main 12V <sub>DC</sub> output the signal requires to be pulled “high” with respect +12V_GND. The value of the pull up resistor is as follows: <ol style="list-style-type: none"> <li>1. If the signal is to be pulled up to the 12VSB output then the resistor value should be 21K<math>\Omega</math></li> <li>2. If the signal is to be pulled up to a 3.3V<sub>DC</sub> rail (locally derived within the host system) then the resistor value should be 5.11K<math>\Omega</math></li> </ol>	The voltage level on the system side of the PSPRESENT# signal will be follows: <ol style="list-style-type: none"> <li>1. When the power module is not installed the voltage will equal the rail to which it is pulled up to (3.3V<sub>DC</sub> or 12V<sub>DC</sub>)</li> <li>2. When the power module is installed, the voltage will be pulled down to 0.54V<sub>DC</sub> <math>\pm</math>5%.</li> </ol>
PS_ON (Power Supply Enable/Disable)	<a href="#">Input</a>	The PS_ON can be permanently connected to +12V_GND (via the host system mid/back plane) to “enable” the Main 12V <sub>DC</sub> output. Alternatively the signal can be connected via the host system electronics to provide the ability to switch between “enable/disable” states. The signal is pulled up internally to the internal housekeeping supply (within the power supply). The power supply main 12V <sub>DC</sub> output will be enabled when this signal is pulled low to +12V_GND. In the low state the signal input shall source a nominal 1.2mA <sub>DC</sub> . The 12V <sub>DC</sub> output will be disabled when the input is driven higher than 2.4V, or open circuited. Cycling this signal shall clear latched fault conditions.	Pulled up internally via 10K to 3.3V <sub>DC</sub> . A logic high >2.0V <sub>DC</sub> A logic low <0.8V <sub>DC</sub> Input is via CMOS Schmitt trigger buffer.
V1_SENSE V1SENSE_R	<a href="#">Input</a>	Remote sense connections are intended to be connected and sense the voltage at the point of load. The voltage sense will interact with the internal module regulation loop to compensate for voltage drops due to connection resistance between the output connector and the load. If remote sense compensation is not required then the voltage can be configured for local sense by: <ul style="list-style-type: none"> <li>• V1_SENSE directly connected to any of the 12V output pins 1-13, 52-64</li> <li>• V1_SENSE_R directly connected to any of the RTN pins 14-26, 39-51</li> </ul>	Compensation for up to 0.12Vdc total connection drop (output and return connections).
ADDR (Address Select)	<a href="#">Input</a>	An analogue input that is used to set the address of the internal slave devices (EEPROM and microprocessor) used for digital communications. Connection of a suitable resistor to +12V_GND, in conjunction with an internal resistor divider chain, will <a href="#">configure the required address</a> .	DC voltage between the limits of 0 and +3.3V <sub>DC</sub> .
SCL (Serial Clock)	<a href="#">Both</a>	A serial clock line compatible with PMBus™ Power Systems Management Protocol Part 1 – General Requirements Rev 1.1. No additional internal capacitance is added that would affect the speed of the bus. The signal is provided with a series isolator device to disconnect the internal power supply bus in the event that the power module is unpowered.	VIL is 0.8V maximum VOL is 0.4V maximum when sinking 3mA VIH is 2.1V minimum
SDA (Serial Data)	<a href="#">Both</a>	A serial data line compatible with PMBus™ Power Systems Management Protocol Part 1 – General Requirements Rev 1.1. The signal is provided with a series isolator device to disconnect the internal power supply bus in the event that the power module is unpowered.	VIL is 0.8V maximum VOL is 0.4V maximum when sinking 3mA VIH is 2.1V minimum

### STATUS INDICATOR CONDITIONS

LED State	Mode	Operating Condition
1. Off	AC Turn-off	The incoming AC source is below the minimum power module turn-on specification
2. Green – blinking 1Hz	Standby	The power module VStandby output is operating within normal parameters and main
3. Green – solid	Power-good	The power module VStandby & Main outputs are operating within normal parameters
4. Yellow – blinking 1Hz	Warning	A warning condition within the power supply has been detected
5. Yellow – solid	Fault	A fault condition within the power supply has been detected.

### TIMING DIAGRAM

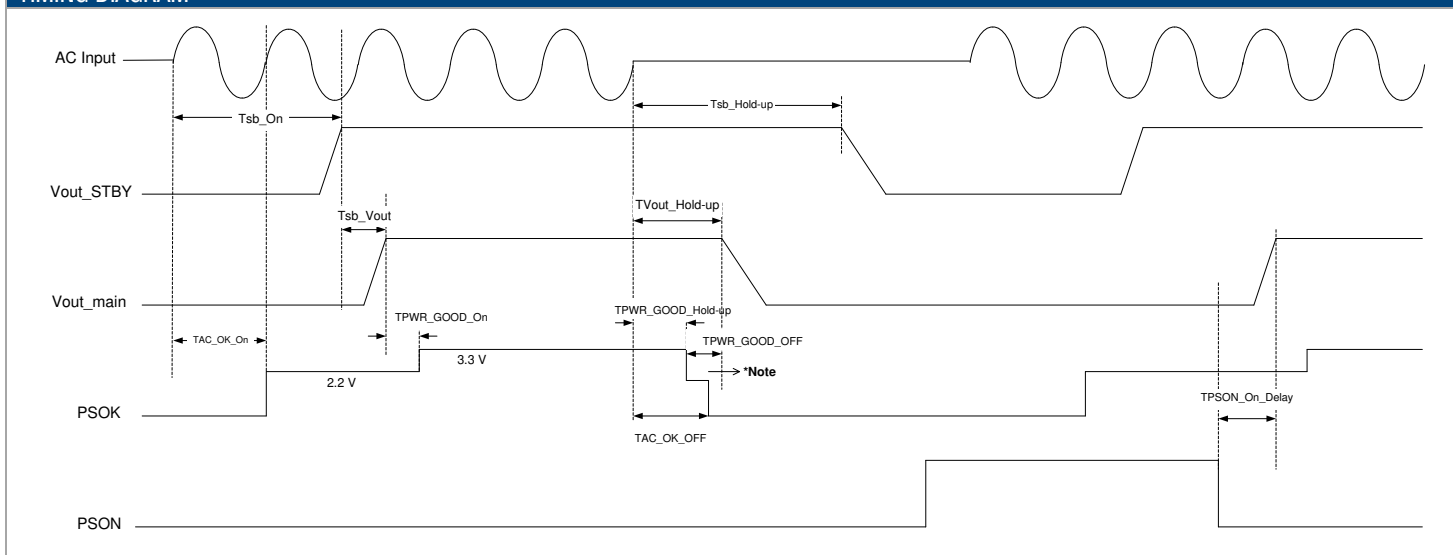

\*NOTE: The PSOK levels after the loss of the incoming AC source may be either 1.1V or 2.2V depending on the relative timing of the TACPOK\_OFF and TPWR\_GOOD\_HOLD-UP

Link back to [Status and Control Signals](#)

### TIMING SPECIFICATIONS

Parameter	Description	Min	Max	Unit
Tsb_On	Delay from AC being applied to standby output being within regulation	0	3000	ms
Tsb_Vout	Delay from standby output to main output voltage being within regulation	50	500	ms
TPWR_GOOD_On	Delay from output voltages within regulation limits to internal PWR_GOOD_H assertion	20	500	ms
TAC_OK_OFF	Delay from loss of AC to de-assertion of AC_OK_H internal signal (100% load)	2	10	ms
TAC_OK_On	Delay from AC being applied to assertion of AC_OK_H internal signal	1	3000	ms
TPWR_GOOD_Hold-up	<sup>1</sup> Delay from loss of AC to de-assertion of PWR_GOOD_H internal signal	7	60	ms
TVout_Hold-up	Delay from loss of AC to main output being out of regulation	12	-	ms
Tsb_Hold-up	Delay from loss of AC to standby output being out of regulation	20	2000	ms
TPWR_GOOD_OFF	Delay from de-assertion of PWR_GOOD_H internal signal to output falling out of regulation	0	2	ms
TPSON_On_Delay	Delay from PSON assertion to output being within regulation	1	200	ms

<sup>1</sup> 100% full load

### OUTPUT CONNECTOR AND SIGNAL SPECIFICATION

Pin#	Function	Pin Type	Description
14-26, 39-51	RTN	Power Ground	Power and Standby Return
1-13, 52-64	12V	Power	12V Output
37	12VSB	Power	12V Standby Output
38	<a href="#">PSINTERRUPT</a>	Output	Active low; interrupt line for power supply fault & warning detection as per PMBus™ spec
36	<a href="#">PRESENT#</a>	Input	Power Supply Present Signal (shortest pin)
35	<a href="#">PSOK</a>	Analog output	Combination of three internal power supply indicator signals: 1. ACOK_H 2. PWOK_H 3. FAULT_L
34	N/A	N/A	Reserved; no user connection
33	<a href="#">PSON#</a>	Input	Power Supply on/off control signal
32	<a href="#">SCL</a>	Input	SMBus/PMBus™ Clock
31	<a href="#">SDA</a>	I/O	SMBus/PMBus™ Data
30	GND	Analog I/O	Power Supply Signal Ground
29	<a href="#">12V SENSE R</a>	Input	Compensation for voltage drops due to connection resistance between the output connector and the load
28	<a href="#">12V SENSE</a>		
27	<a href="#">ADDR</a>	Analog input	PMBus™ Address <a href="#">see value table</a>

### Power Supply Output Card Edge

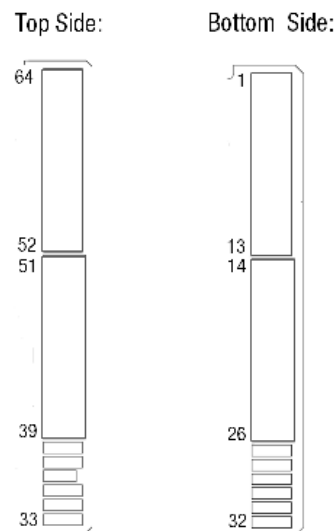

### MATING CONNECTOR

Part Number	Description
FCI 10053363-200LF	Right Angle
FCI 10046971-001LF	Vertical

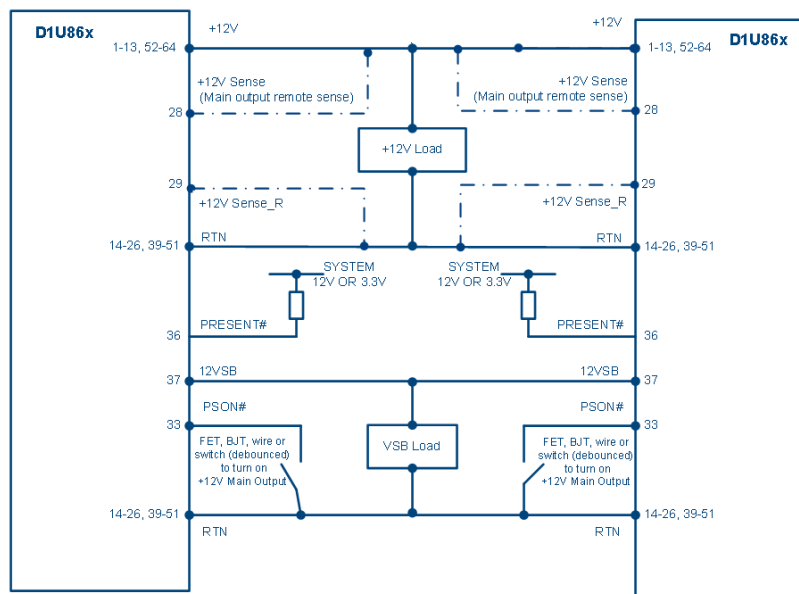

### WIRING DIAGRAM FOR FOR OUTPUT



### CURRENT SHARING NOTES

- 12V Output: Current sharing is achieved using droop share method.
- 12VSB Outputs can be tied together for redundancy however the combined output power must not exceed the rated standby power of a single unit.
- 12VSB Output has an internal ORing MOSFET for additional redundancy and fault tolerance.
- The load for both the main 12V and the 12VSBY outputs during startup shall not be allowed to exceed the capability of a single unit. Higher load current may be applied after a delay of 3sec (minimum) to allow all sharing units to achieve steady state regulation.

## MECHANICAL DIMENSIONS

  
 D1U86P-W-2200-12-HB3DC – Airflow Front to Back
   

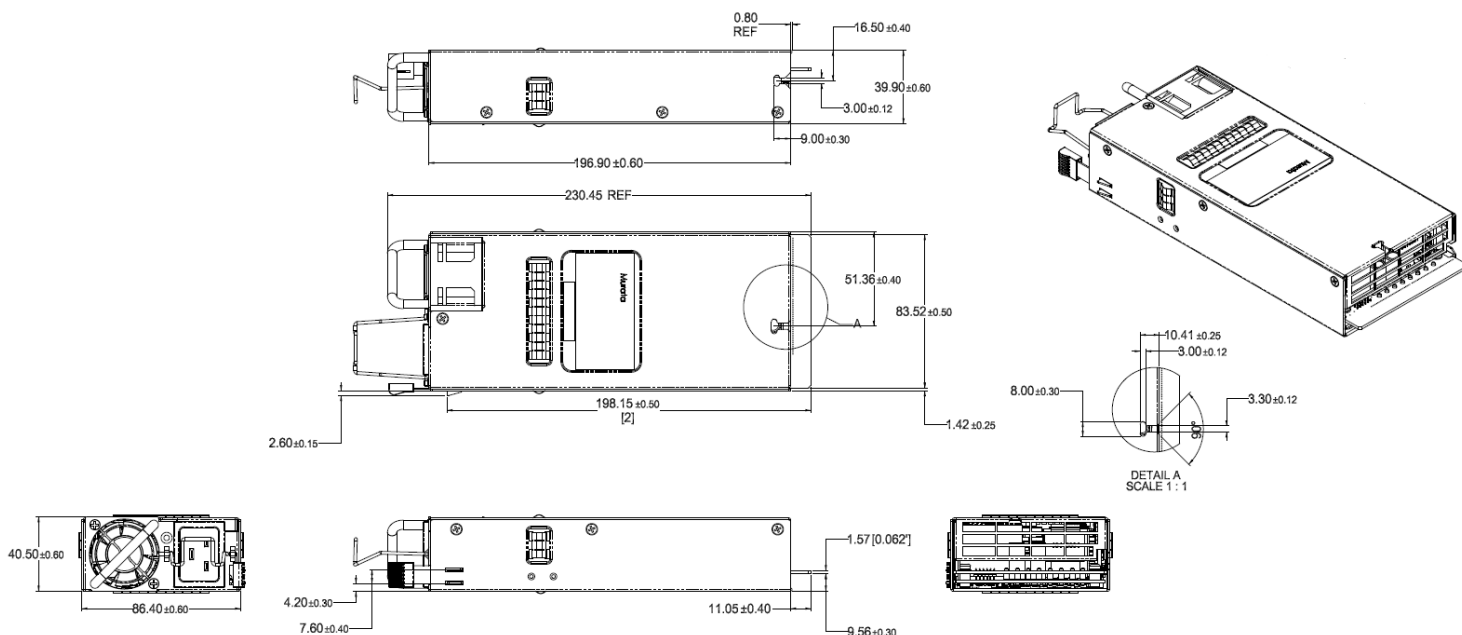
  
 D1U86P-W-2200-12-HB4DC – Airflow Back to Front



### Notes

1. AC input connector: IEC 60320-C20
2. Dimensions: 86.4 mm x 197.7mm x 40.5mm [3.4" x 7.78" x 1.59"]; metric measurements take precedent
3. This drawing is a graphical representation of the product and may not show all fine details.
4. Reference File: I:\Eng\_wip\UserPDDwg\1830\D1U86P-W-2200-12-HB3C\_M1830-260CT17
5. Dimensions in mm unless otherwise noted
6. For illustration purposes of the envelope and main features only. Refer to 3D model should additional detail be required.

### ADDR ADDRESS SELECTION

ADDR pin resistor to GND (K-ohm, ±5%)	Power Supply Main Controller (Serial Communications Slave Address)	Power Supply External EEPROM (Serial Communications Slave Address)
0.82	0xB0	0xA0
2.7	0xB2	0xA2
5.6	0xB4	0xA4
8.2	0xB6	0xA6
15	0xB8	0xA8
27	0xBA	0xAA
56	0xBC	0xAC
180	0xBE	0xAE

Link Back to [Status and Control Signals](#), [Pinout Table](#)

### Airflow Characteristics

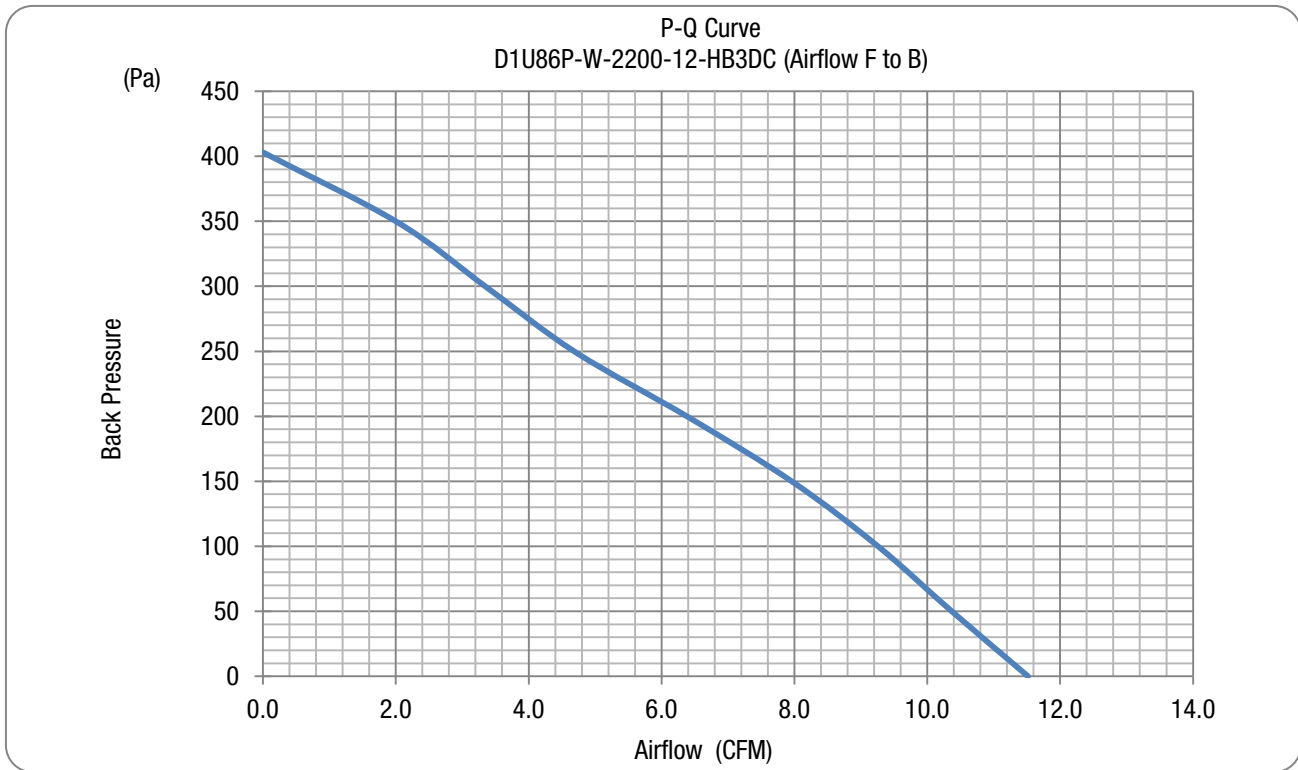

### OPTIONAL ACCESSORIES

Description	Part Number
12V D1U86P Output Connector Card	D1U86P-CONC-2200W

### APPLICATION NOTES

Document Number	Description	Link to Document
ACAN-75	D1U86P Output Connector Card	<a href="http://power.murata.com/datasheet?/data/apnotes/acan-75.pdf">http://power.murata.com/datasheet?/data/apnotes/acan-75.pdf</a>
ACAN-76	D1U86P-W-2200 Communication Protocol	<a href="http://power.murata.com/datasheet?/data/apnotes/acan-76.pdf">http://power.murata.com/datasheet?/data/apnotes/acan-76.pdf</a>

[Back to introduction](#)

### MPS part number Guide:

Product	Internal MPS#
D1U86P-W-2200-12-HB3DC	M1830
D1U86P-W-2200-12-HB4DC	M2000
D1U86P-CONC-2200W	M7018

Murata Power Solutions, Inc.  
129 Flanders Rd. Westborough, Ma 01581, USA.  
ISO 9001 and 14001 REGISTERED

**This product is subject to the following operating requirements and the Life and Safety Critical Application Sales Policy:**

**Refer to:** <http://www.murata-ps.com/requirements/>

Murata Power Solutions, Inc. makes no representation that the use of its products in the circuits described herein, or the use of other technical information contained herein, will not infringe upon existing or future patent rights. The descriptions contained herein do not imply the granting of licenses to make, use, or sell equipment constructed in accordance therewith. Specifications are subject to change without notice.

©2016 Murata Power Solutions, Inc.