



The Future of Analog IC Technology®

EV3217DJ-00A

670kHz, 70V

Voltage Doubler Evaluation Board

GENERAL DESCRIPTION

The EV3217DJ-00A is the evaluation board for Voltage Doubler Circuit. It is implemented by MP3217, a current mode step up converter intended for small, low power applications. The MP3217 switches at 670kHz and allows the use of tiny, low cost capacitors and inductors to achieve a compact solution.

The MP3217 includes under-voltage lockout, over voltage protection and thermal overload protection preventing damage in the event of an output overload. The MP3217 is available in small 6-pin TSOT23 package.

FEATURES

- Internal 0.6Ω Power MOSFET
- Up to 70V Output Voltage
- 670kHz Fixed Switching Frequency
- Over Voltage Shutdown
- Cycle-by-Cycle Over Current Protection
- UVLO, Thermal Shutdown
- Available in TSOT23-6 Packages

APPLICATIONS

- APD Bias Generation
- Portable Applications
- Handheld Computers and PDAs
- Digital Still Cameras

ELECTRICAL SPECIFICATION

Parameter	Symbol	Value	Units
Input Voltage	V _{IN}	3.3	V
Output Voltage	V _{OUT}	70	V
Output Current	I _{OUT}	1	mA

"MPS" and "The Future of Analog IC Technology" are Registered Trademarks of Monolithic Power Systems, Inc.

EV3217DJ-00A EVALUATION BOARD



(L x W x H) 2.0" x 1.8" x 0.2"
5.0cm x 4.5cm x 0.5cm

Board Number	MPS IC Number
EV3217DJ-00A	MP3217DJ

EVALUATION BOARD SCHEMATIC

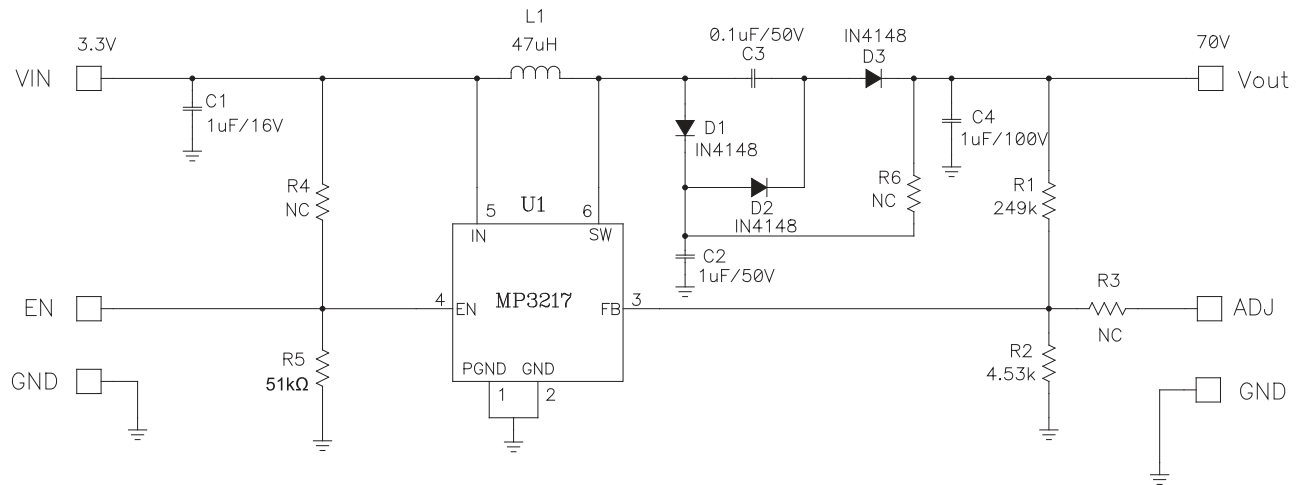

EV3217DJ-00A BILL OF MATERIALS

Qty	Ref	Value	Description	Package	Manufacturer	Part Number
1	C1	1µF	Ceramic Capacitor, 16V, X7R	0805	muRata	GRM21BR71C105KA01L
1	C2	1µF	Ceramic Capacitor, 50V, X7R	0805	muRata	GRM21BR71H105KA12L
1	C3	0.1µF	Ceramic Capacitor, 50V, X7R	0805	muRata	GRM21BR71H104KA01L
1	C4	1µF	Ceramic Capacitor, 100V, X7R	1210	muRata	GRM32ER72A105KA01L
3	D1, D2, D3	1N4148	Diode, 75V, 0.15A	SOD-323	Diodes Inc.	1N4148WS-7-F
1	L1	47µH	Inductor, 0.53A	D63LCB	TOKO	D63LCB-#A921CY-470M
1	R1	249kΩ	Resistor, 1%	0603	Yageo	RC0603FR-07249KL
1	R2	4.53kΩ	Resistor, 1%	0603	Yageo	RC0603FR-074K53L
3	R3, R4, R6	NC				
1	R5	51kΩ	Resistor	0603	Any	
1	U1	MP3217	Boost Converter	TSOT23-6	MPS	MP3217DJ-LF-Z

PRINTED CIRCUIT BOARD LAYOUT

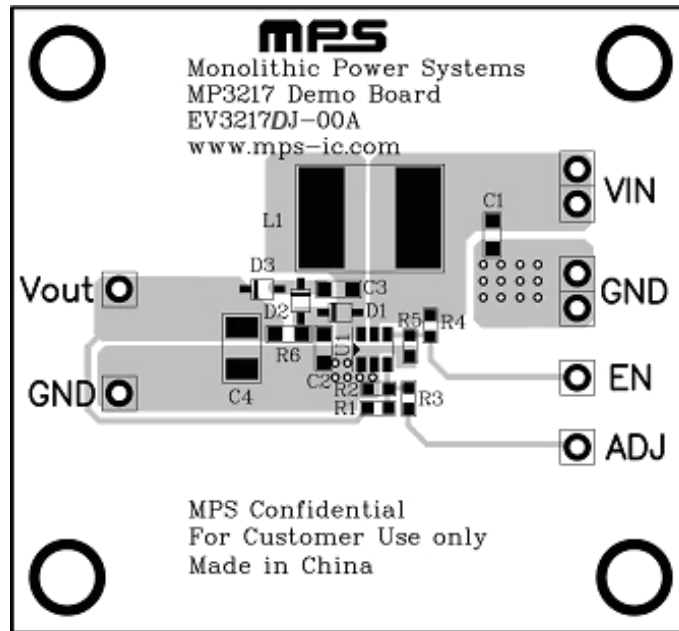

Figure 1—Top Layer

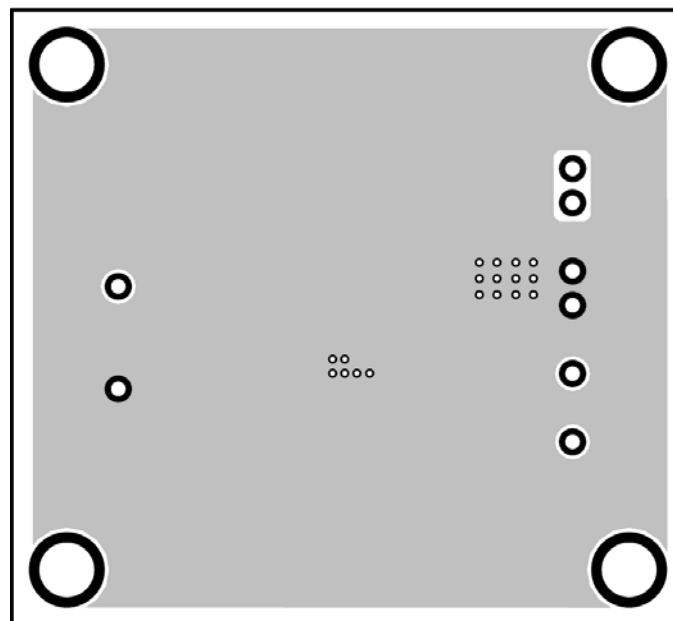

Figure 2—Bottom Layer

QUICK START GUIDE

The output voltage of this board is set to 70V. The board layout accommodates most commonly used inductors and output capacitors.

1. Preset Power Supply to $V_{IN} = 3.3V$.
2. Turn Power Supply off.
3. Connect Power Supply terminals to:
 - Positive (+): V_{in}
 - Negative (-): GND
4. Connect Load to:
 - Positive (+): V_{out}
 - Negative (-): GND
5. Turn Power Supply on after making connections.
6. The MP3217 is enabled once $V_{EN} > 2V$. To disable the MP3217, short EN to GND.
7. The output voltage V_{OUT} can be changed by varying R1. Calculate the new value using the formula:

$$R1 = \frac{R2(V_{OUT} - V_{FB})}{V_{FB}}$$

Where $V_{FB} = 1.24V$ and $R2 = 4.53k\Omega$

For example, for $V_{OUT} = 70V$

$$R1 = \left(\frac{70 - 1.24}{1.24} \right) \times 4.53k\Omega = 251.19k\Omega$$

There choose a 249 kΩ standard 1% value.

8. The output voltage V_{OUT} can be also modified by external adjustable voltage V_{ADJ} thru ADJ pin. Calculate the adjustable voltage value using the formula:

$$V_{ADJ} = \left(1 + \frac{R3}{R1} + \frac{R3}{R2} \right) \cdot V_{FB} - \frac{R3}{R1} \cdot V_{OUT}$$

9. For normal boost application, open D2, D3, C2 and short R6, the output voltage can be boosted up to 36V by varying R1 using the formula above.

NOTICE: The information in this document is subject to change without notice. Please contact MPS for current specifications. Users should warrant and guarantee that third party Intellectual Property rights are not infringed upon when integrating MPS products into any application. MPS will not assume any legal responsibility for any said applications.