

P.C.B. HOLE DRILLINGS
 (P.C.B. TOP SIDE)

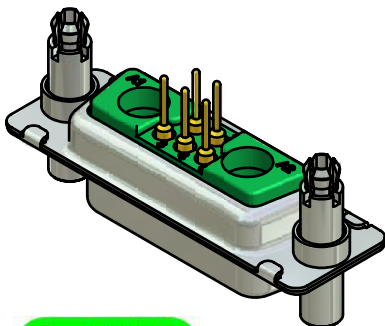
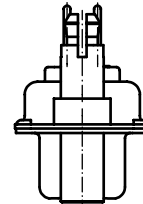
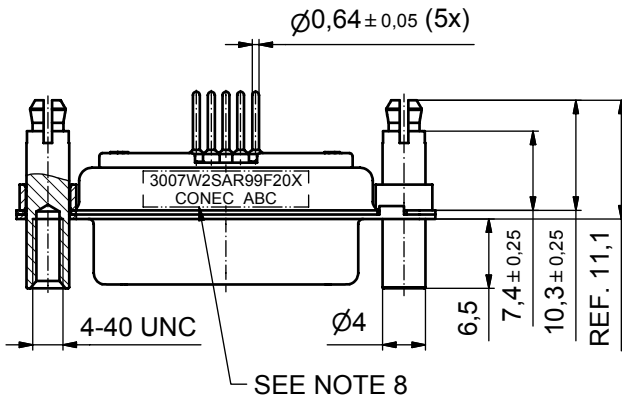
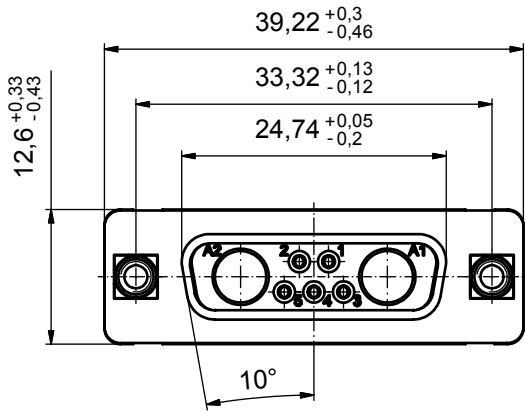
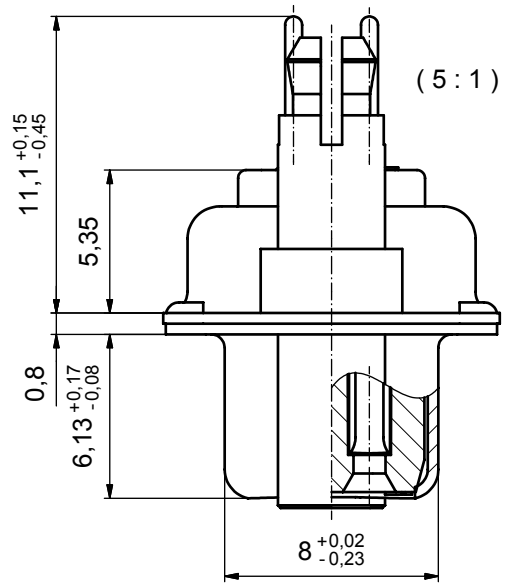

NOTES:

- METALSHELLS: STEEL; min. 315µm TIN over 40-80µm NICKEL
- INSULATORS: PBT GF UL 94 V-0; GREEN
- SIGNAL CONTACTS: COPPER ALLOY
 PLATING: 8µm HARD GOLD over min. 50µm NICKEL
- NO CONTACTS ON POS A1 + A2
- THREADED LOCKS AND SPACER CLIPS: COPPER ALLOY; min. 200µm TIN over 80µm NICKEL
 PCB-HOLE: Ø3,1 ± 0,1mm; PCB-THICKNESS: 1,6mm
- COLLARS: COPPER ALLOY; min. 200µm TIN over 80µm NICKEL
- MAXIMUM TORQUE VALUE FOR THREAD: 6 in.LB
- CONNECTOR IS PART MARKED: 3007W2SAR99F20X CONEC ABC

Directive 2002/95/EC
 „RoHS“
 Compliant

APPROVAL # FREIGABE # DEBLOCAGE # AUTORIZACION # APPROVAL	
CUSTOMER APPROVAL DATE:	
NAME:	TITLE:
COMPANY NAME:	
APPROVAL # FREIGABE # DEBLOCAGE # AUTORIZACION # APPROVAL	

THIS DRAWING MAY NOT BE COPIED OR REPRODUCED IN ANY WAY, AND MAY NOT BE PASSED ON TO A THIRD PARTY WITHOUT WRITTEN PERMISSION. OWNERSHIP AND COPYRIGHT OF CONEC GmbH			
DO NOT ALTER CAD DRAWING BY HAND			
rev.	description	date	name

tolerance	dim. in mm
date	name
drawn	29.10.09 Lehmenkühler
appd.	30.10.09 Koch
norm	
d-old	
CONEC	

scale:	2:1 (5:1)	
material:	SEE NOTES	
title:	D-SUB COMBINATION FEMALE 7W2S with threaded lock and spacer clip	
dwg no:	Inventor 10	DIN-A3
	13K1A2995	sh: 1
part no:	3007W2SAR99F20X	