

REVISION

THIS PRODUCT MANUFACTURED WITH LEAD-FREE PROCESSING

DESIGNED & DIMENSIONED IN MILLIMETERS [INCHES]

DO NOT SCALE FROM THIS PRINT

TNC-P-C-XX-ST-CA1S

GENDER -P: PLUG
 TYPE -C: CABLE
 TERMINATION CA1S: CCA-316-S (RG-316 CABLE, DOUBLE SHIELD)
 ORIENTATION -ST: STRAIGHT

PLATING SPECIFICATION
 -GN: 10μ" GOLD CENTER CONTACT,
 3μ" GOLD OUTER CONTACT
 100μ" NICKEL REMAINING PARTS
 (SEE TABLE 1)

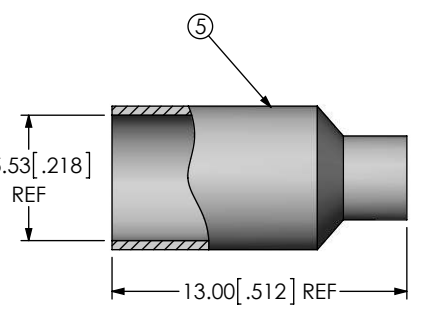
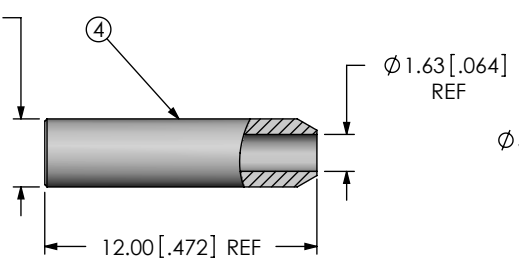
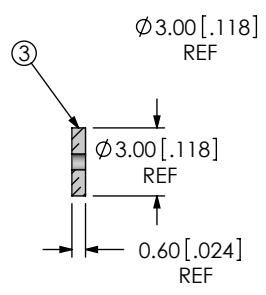
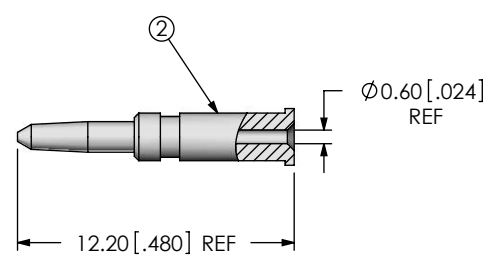
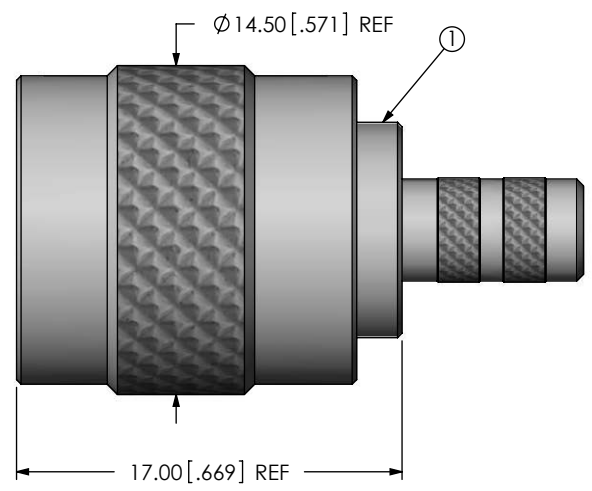



TABLE 1

| ITEM | COMPONENT | -GN |
|------|--------------|----------------------|
| 1 | SUB ASSEMBLY | SUB-TNC-P-C-N-ST-CA1 |
| 2 | PIN | TNC-PIN-001-G |
| 3 | INSULATOR | TNC-INS-001 |
| 4 | FERRULE 1 | TNC-FER-001-N |
| 5 | FERRULE 2 | TNC-FER-005-N |

- NOTES:
- ① REPRESENTS A CRITICAL DIMENSION.
 - PRODUCT TO BE PACKAGED PER PACKING STANDARD CO-RF-WI-3040-M.
 TRAY: TY-BNC002-1
 COVER: TY-BNC002-2
 36 PARTS PER TRAY (1 PARTS PER POCKET).
 - PIN & FERRULE TO BE PACKAGED SEPARATELY.

| | | | |
|---------------------------------------------------------------------------------------------------------------------------------------------------------------------------|--------------------------------------------------------------------------------------------------------------------------------------------------------------------------------------------------------------------------------------------------------------------------------------------------------------|-----------------------------------------------------------------------------------------------------------------------------------------------------------------------------------------------------------------|--|
| UNLESS OTHERWISE SPECIFIED DIMENSIONS ARE IN MILLIMETERS [INCHES] TOLERANCES ARE: DECIMALS ANGLES .X: ±0.3 [.01] 5° .XX: ±0.13 [.005] .XXX: ±0.051 [.0020] | PROPRIETARY NOTE THIS DOCUMENT CONTAINS INFORMATION CONFIDENTIAL AND PROPRIETARY TO SAMTEC, INC. AND SHALL NOT BE REPRODUCED OR TRANSFERRED TO OTHER DOCUMENTS OR DISCLOSED TO OTHERS OR USED FOR ANY PURPOSE OTHER THAN THAT WHICH IT WAS OBTAINED WITHOUT THE EXPRESSED WRITTEN CONSENT OF SAMTEC, INC. |  520 PARK EAST BLVD, NEW ALBANY, IN 47150 PHONE: 812-944-6733 FAX: 812-948-5047 e-Mail info@SAMTEC.com code 55322 | |
| | | DESCRIPTION: TNC STRAIGHT CABLE PLUG, RD316 - 50 OHM | |
| MATERIAL: DO NOT SCALE DRAWING SHEET SCALE: 3:1 SHELL, FERRULE: BRASS CONTACT: BRASS DIELECTRIC: PTFE GASKET: SILICONE | | DWG. NO. TNC-P-C-XX-ST-CA1S | |
| BY: ALVIN W 06/27/2013 | | SHEET 1 OF 2 | |



IN-PROCESS 1
STRIP AND TIN INNER CONDUCTOR

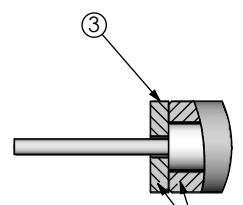

DETAIL 'B'
SCALE 4 : 1

TNC-INS-001 & TNC-FER-001-X
TO BE FLUSH WITH CABLE DIELECTRIC

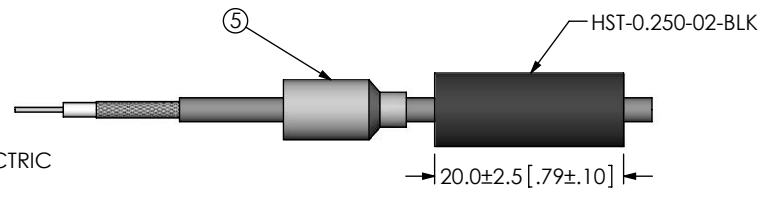

IN-PROCESS 2
ADD HEAT SHRINK TUBE AND FERRULE

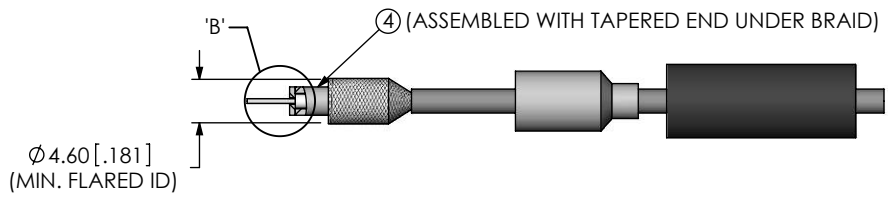

IN-PROCESS 3
FLARE SHIELD, ADD INNER FERRULE AND INSULATOR

0.45 [.018] REF
TO CENTER CONTACT

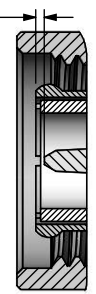

DETAIL 'A'
SCALE 2.5 : 1

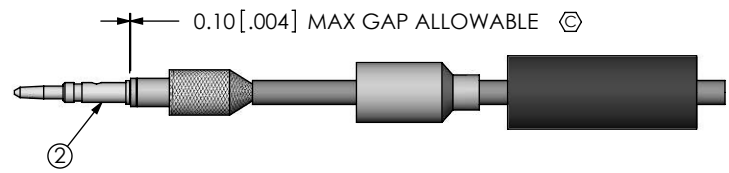

IN-PROCESS 4
SOLDER SIGNAL PIN

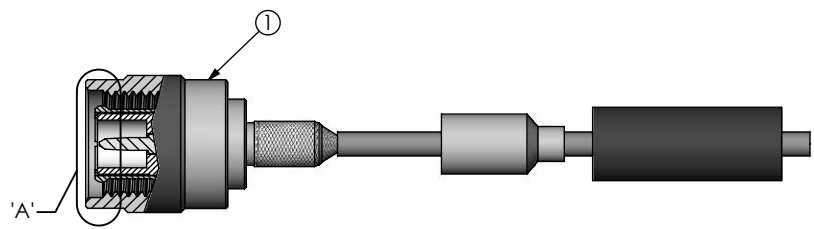

IN-PROCESS 5
ADD SUB-TNC-P-C-X-ST-CA1

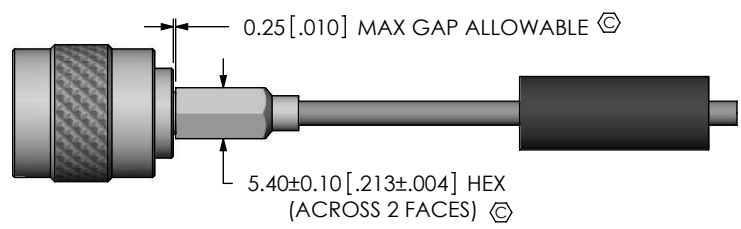

IN-PROCESS 6
"CRIMP FERRULE"
(USE RF CRIMP HAND TOOL #CAT-HT-126667-21 OR EQUIVALENT)
(USE .213" HEX DIE)

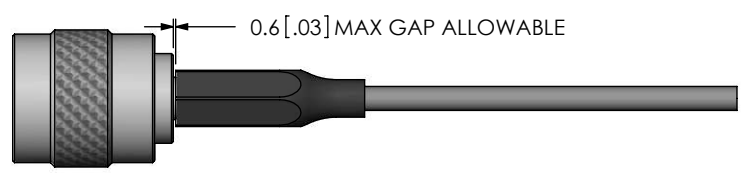

IN-PROCESS 7
APPLY HEAT SHRINK TUBE

| | | | |
|-------------------------------------------------------------------------------------------------------------------------------------------------------------------------------------------------------------------------------------------------------------------------------------------------------------------------|-----------------------------------------------------------------------------------------------------------------------------------|-----------------------------------------------------------------|---------------------|
| <p>PROPRIETARY NOTE</p> <p>THIS DOCUMENT CONTAINS INFORMATION CONFIDENTIAL AND PROPRIETARY TO SAMTEC, INC. AND SHALL NOT BE REPRODUCED OR TRANSFERRED TO OTHER DOCUMENTS OR DISCLOSED TO OTHERS OR USED FOR ANY PURPOSE OTHER THAN THAT WHICH IT WAS OBTAINED WITHOUT THE EXPRESSED WRITTEN CONSENT OF SAMTEC, INC.</p> | | | |
| | <p>520 PARK EAST BLVD., NEW ALBANY, IN 47150 PHONE: 812-944-6733 FAX: 812-948-5047 e-Mail: info@SAMTEC.com code 55322</p> | | |
| | <p>DO NOT SCALE DRAWING</p> | <p>DESCRIPTION: TNC STRAIGHT CABLE PLUG, RD316 - 50 OHM</p> | |
| <p>SHEET SCALE: 1:0.8</p> | <p>DWG. NO. TNC-P-C-XX-ST-CA1S</p> | | |
| | <p>BY: ALVIN W</p> | <p>06/27/2013</p> | <p>SHEET 2 OF 2</p> |