



The following document contains information on Cypress products. The document has the series name, product name, and ordering part numbering with the prefix “MB”. However, Cypress will offer these products to new and existing customers with the series name, product name, and ordering part number with the prefix “CY”.

#### **How to Check the Ordering Part Number**

1. Go to [www.cypress.com/pcn](http://www.cypress.com/pcn).
2. Enter the keyword (for example, ordering part number) in the **SEARCH PCNS** field and click **Apply**.
3. Click the corresponding title from the search results.
4. Download the Affected Parts List file, which has details of all changes

#### **For More Information**

Please contact your local sales office for additional information about Cypress products and solutions.

#### **About Cypress**

Cypress is the leader in advanced embedded system solutions for the world's most innovative automotive, industrial, smart home appliances, consumer electronics and medical products. Cypress' microcontrollers, analog ICs, wireless and USB-based connectivity solutions and reliable, high-performance memories help engineers design differentiated products and get them to market first. Cypress is committed to providing customers with the best support and development resources on the planet enabling them to disrupt markets by creating new product categories in record time. To learn more, go to [www.cypress.com](http://www.cypress.com).



The MB9A310K Series are a highly integrated 32-bit microcontrollers dedicated for embedded controllers with high-performance and low cost.

These series are based on the ARM® Cortex®-M3 Processor with on-chip Flash memory and SRAM, and has peripheral functions such as Motor Control Timers, ADCs and Communication Interfaces (USB, UART, CSIO, I<sup>2</sup>C, LIN).

The products which are described in this Datasheet are placed into TYPE5 product categories in "FM3 Family Peripheral Manual".

## Features

### 32-bit ARM Cortex-M3 Core

- Processor version: r2p1
- Up to 40MHz Frequency Operation
- Integrated Nested Vectored Interrupt Controller (NVIC): 1 NMI (non-maskable interrupt) and 48 peripheral interrupts and 16 priority levels
- 24-bit System timer (Sys Tick): System timer for OS task management

### On-chip Memories

#### [Flash memory]

This Series are based on two independent on-chip Flash memories.

- MainFlash
  - Up to 128Kbyte
  - Read cycle: 0 wait-cycle
  - Security function for code protection
- WorkFlash
  - 32Kbyte
  - Read cycle: 0 wait-cycle
  - Security function is shared with code protection

#### [SRAM]

This Series contain a total of up to 16Kbyte on-chip SRAM. This is composed of two independent SRAM (SRAM0, SRAM1). SRAM0 is connected to I-code bus and D-code bus of Cortex-M3 core. SRAM1 is connected to System bus.

- SRAM0: 8 Kbyte
- SRAM1: 8 Kbyte

### USB Interface

USB interface is composed of Device and Host. PLL for USB is built-in, USB clock can be generated by multiplication of Main clock.

#### [USB device]

- USB2.0 Full-Speed supported
- Max 6 EndPoint supported
  - EndPoint 0 is control transfer
  - EndPoint 1, 2 can be selected Bulk-transfer, Interrupt-transfer or Isochronous-transfer
  - EndPoint 3 to 5 can be selected Bulk-transfer or Interrupt-transfer
  - EndPoint 1 to 5 is comprised Double Buffer
  - The size of each EndPoint is as follows.
    - EndPoint 0, 2 to 5: 64 bytes
    - EndPoint 1: 256 bytes

#### [USB host]

- USB2.0 Full/Low-speed supported
- Bulk-transfer, interrupt-transfer and Isochronous-transfer support
- USB Device connected/dis-connected automatically detect
- IN/OUT token handshake packet automatically
- Max 256-byte packet-length supported
- Wake-up function supported

### Multi-function Serial Interface (Max 4 channels)

- 2 channels with 16-steps × 9-bits FIFO (ch.0, ch.1), 2 channels without FIFO (ch.3, ch.5)
- Operation mode is selectable from the followings for each channel. (In ch.5, only UART and LIN are available.)
  - UART
  - CSIO
  - LIN
  - I<sup>2</sup>C

**[UART]**

- Full-duplex double buffer
- Selection with or without parity supported
- Built-in dedicated baud rate generator
- External clock available as a serial clock
- Hardware Flow control: Automatically control the transmission by CTS/RTS (only ch.4)
- Various error detect functions available (parity errors, framing errors, and overrun errors)

**[CSIO]**

- Full-duplex double buffer
- Built-in dedicated baud rate generator
- Overrun error detect function available

**[LIN]**

- LIN protocol Rev.2.1 supported
- Full-duplex double buffer
- Master/Slave mode supported
- LIN break field generate (can be changed 13 to 16-bit length)
- LIN break delimiter generate (can be changed 1 to 4-bit length)
- Various error detect functions available (parity errors, framing errors, and overrun errors)

**[I<sup>2</sup>C]**

- Standard mode (Max 100 kbps) / Fast-mode (Max 400 kbps) supported

**DMA Controller (4 channels)**

DMA Controller has an independent bus for CPU, so CPU and DMA Controller can process simultaneously.

- 8 independently configured and operated channels
- Transfer can be started by software or request from the built-in peripherals
- Transfer address area: 32-bit (4 Gbyte)
- Transfer mode: Block transfer/Burst transfer/Demand transfer
- Transfer data type: byte/half-word/word
- Transfer block count: 1 to 16
- Number of transfers: 1 to 65536

**A/D Converter (Max 8 channels)**
**[12-bit A/D Converter]**

- Successive Approximation Register type
- Built-in 2 unit
- Conversion time: 1.0  $\mu$ s@5 V
- Priority conversion available (priority at 2 levels)
- Scanning conversion mode
- Built-in FIFO for conversion data storage (for SCAN conversion: 16 steps, for Priority conversion: 4 steps)

**Base Timer (Max 8 channels)**

Operation mode is selectable from the followings for each channel.

- 16-bit PWM timer
- 16-bit PPG timer
- 16-/32-bit reload timer
- 16-/32-bit PWC timer

**General Purpose I/O Port**

This series can use its pins as General Purpose I/O ports when they are not used for external bus or peripherals. Moreover, the port relocate function is built in. It can set which I/O port the peripheral function can be allocated.

- Capable of pull-up control per pin
- Capable of reading pin level directly
- Built-in the port relocate function
- Up 36 fast General Purpose I/O Ports
- Some pin is 5V tolerant I/O.  
See "Pin Description" to confirm the corresponding pins.

**Multi-function Timer**

The Multi-function Timer is composed of the following blocks.

- 16-bit free-run timer  $\times$  3 ch.
- Input capture  $\times$  4 ch.
- Output compare  $\times$  6 ch.
- A/D activating compare  $\times$  3 ch.
- Waveform generator  $\times$  3 ch.
- 16-bit PPG timer  $\times$  3 ch.

The following function can be used to achieve the motor control.

- PWM signal output function
- DC chopper waveform output function
- Dead time function
- Input capture function
- A/D convertor activate function

- DTIF (Motor emergency stop) interrupt function

### Real-time clock (RTC)

The Real-time clock can count Year/Month/Day/Hour/Minute/Second/A day of the week from 00 to 99.

- Interrupt function with specifying date and time (Year/Month/Day/Hour/Minute) is available. This function is also available by specifying only Year, Month, Day, Hour or Minute.
- Timer interrupt function after set time or each set time.
- Capable of rewriting the time with continuing the time count.
- Leap year automatic count is available.

### Quadrature Position/Revolution Counter (QPRC)

The Quadrature Position/Revolution Counter (QPRC) is used to measure the position of the position encoder. Moreover, it is possible to use up/down counter.

- The detection edge of the three external event input pins AIN, BIN and ZIN is configurable.
- 16-bit position counter
- 16-bit revolution counter
- Two 16-bit compare registers

### Dual Timer (32-/16-bit Down Counter)

The Dual Timer consists of two programmable 32-/16-bit down counters. Operation mode is selectable from the followings for each channel.

- Free-running
- Periodic (= Reload)
- One-shot

### Watch Counter

The Watch counter is used for wake up from Low Power Consumption mode.

- Interval timer: up to 64 s (Max) @ Sub Clock: 32.768 kHz

### External Interrupt Controller Unit

- Up to 6 external interrupt input pin
- Include one non-maskable interrupt (NMI)

### Watchdog Timer (2channels)

A watchdog timer can generate interrupts or a reset when a time-out value is reached.

This series consists of two different watchdogs, a "Hardware" watchdog and a "Software" watchdog.

"Hardware" watchdog timer is clocked by low-speed internal CR oscillator. Therefore, "Hardware" watchdog is active in any power saving mode except RTC and STOP and Deep stand-by RTC and Deep stand-by STOP.

### CRC (Cyclic Redundancy Check) Accelerator

The CRC accelerator helps a verify data transmission or storage integrity.

CCITT CRC16 and IEEE-802.3 CRC32 are supported.

- CCITT CRC16 Generator Polynomial: 0x1021
- IEEE-802.3 CRC32 Generator Polynomial: 0x04C11DB7

### Clock and Reset

#### [Clocks]

Five clock sources (2 external oscillators, 2 internal CR oscillator, and Main PLL) that are dynamically selectable.

- Main Clock: 4 MHz to 48 MHz
- Sub Clock: 32.768 kHz
- High-speed internal CR Clock: 4 MHz
- Low-speed internal CR Clock: 100 kHz
- Main PLL Clock

#### [Resets]

- Reset requests from INITX pin
- Power on reset
- Software reset
- Watchdog timers reset
- Low-voltage detector reset
- Clock supervisor reset

### Clock Super Visor (CSV)

Clocks generated by internal CR oscillators are used to supervise abnormality of the external clocks.

- External OSC clock failure (clock stop) is detected, reset is asserted.
- External OSC frequency anomaly is detected, interrupt or reset is asserted.

### Low-Voltage Detector (LVD)

This Series include 2-stage monitoring of voltage on the VCC pins. When the voltage falls below the voltage has been set, Low-Voltage Detector generates an interrupt or reset.

- LVD1: error reporting via interrupt
- LVD2: auto-reset operation

**Low Power Consumption Mode**

Six Low Power Consumption modes supported.

- SLEEP
- TIMER
- RTC
- STOP
- Deep stand-by RTC
- Deep stand-by STOP

**Debug**

Serial Wire JTAG Debug Port (SWJ-DP)

**Power Supply**

- Wide range voltage:  
VCC = 2.7 V to 5.5 V
- Power supply for USB I/O:  
USBVCC0 = 3.0 V to 3.6 V (when USB is used)  
= 2.7 V to 5.5 V (when GPIO is used)

## Contents

<b>1.</b>	<b>Product Lineup</b> .....	<b>7</b>
<b>2.</b>	<b>Packages</b> .....	<b>8</b>
<b>3.</b>	<b>Pin Assignment</b> .....	<b>9</b>
<b>4.</b>	<b>List of Pin Functions</b> .....	<b>12</b>
<b>5.</b>	<b>I/O Circuit Type</b> .....	<b>21</b>
<b>6.</b>	<b>Handling Precautions</b> .....	<b>26</b>
6.1	Precautions for Product Design.....	26
6.2	Precautions for Package Mounting .....	27
6.3	Precautions for Use Environment.....	28
<b>7.</b>	<b>Handling Devices</b> .....	<b>29</b>
<b>8.</b>	<b>Block Diagram</b> .....	<b>32</b>
<b>9.</b>	<b>Memory Size</b> .....	<b>32</b>
<b>10.</b>	<b>Memory Map</b> .....	<b>33</b>
<b>11.</b>	<b>Pin Status in Each CPU State</b> .....	<b>36</b>
<b>12.</b>	<b>Electrical Characteristics</b> .....	<b>42</b>
12.1	Absolute Maximum Ratings.....	42
12.2	Recommended Operating Conditions .....	44
12.3	DC Characteristics .....	45
12.3.1	Current Rating.....	45
12.3.2	Pin Characteristics .....	48
12.4	AC Characteristics .....	49
12.4.1	Main Clock Input Characteristics.....	49
12.4.2	Sub Clock Input Characteristics .....	50
12.4.3	Internal CR Oscillation Characteristics .....	50
12.4.4	Operating Conditions of Main and USB PLL (In the case of using main clock for input of PLL .....	51
12.4.5	Operating Conditions of Main PLL (In the case of using high-speed internal CR).....	51
12.4.6	Reset Input Characteristics .....	52
12.4.7	Power-on Reset Timing.....	52
12.4.8	Base Timer Input Timing .....	53
12.4.9	CSIO/UART Timing.....	54
12.4.10	External Input Timing .....	62
12.4.11	Quadrature Position/Revolution Counter timing .....	63
12.4.12	I <sup>2</sup> C Timing .....	65
12.4.13	JTAG Timing .....	66
12.5	12-bit A/D Converter .....	67
12.6	USB Characteristics .....	70
12.7	Low-voltage Detection Characteristics .....	74
12.7.1	Low-voltage Detection Reset .....	74
12.7.2	Interrupt of Low-voltage Detection .....	74
12.8	MainFlash Memory Write/Erase Characteristics .....	75
12.8.1	Write / Erase time.....	75
12.8.2	Erase/write cycles and data hold time.....	75
12.9	WorkFlash Memory Write/Erase Characteristics .....	75
12.9.1	Write / Erase time.....	75
12.9.2	Erase/write cycles and data hold time.....	75
12.10	Return Time from Low-Power Consumption Mode .....	76
12.10.1	Return Factor: Interrupt/WKUP .....	76
12.10.2	Return Factor: Reset.....	78
<b>13.</b>	<b>Ordering Information</b> .....	<b>80</b>
<b>14.</b>	<b>Package Dimensions</b> .....	<b>81</b>
<b>15.</b>	<b>Major Changes</b> .....	<b>84</b>

Document History .....	86
Sales, Solutions, and Legal Information.....	87

## 1. Product Lineup

### Memory size

Product name		MB9AF311K	MB9AF312K
On-chip Flash memory	MainFlash	64 Kbyte	128 Kbyte
	WorkFlash	32 Kbyte	32 Kbyte
On-chip SRAM	SRAM0	8 Kbyte	8 Kbyte
	SRAM1	8 Kbyte	8 Kbyte
	Total	16 Kbyte	16 Kbyte

### Function

Product name		MB9AF311K MB9AF312K
Pin count		48/52
CPU		Cortex-M3
Freq.		40 MHz
Power supply voltage range		2.7 V to 5.5 V (USBVCC: 3.0 V to 3.6 V)
USB2.0 (Device/Host)		1 ch. (Max)
DMAC		4 ch. (Max)
Multi-function Serial Interface (UART/CSIO/LIN/I <sup>2</sup> C)		4 ch. (Max) with 16-steps × 9-bits FIFO : ch.0, ch.1 without FIFO : ch.3, ch.5 (In ch.5, only UART and LIN are available.)
Base Timer (PWC/ Reload timer/PWM/PPG)		8 ch. (Max)
MF-Timer	A/D activation compare	3 ch.
	Input capture	4 ch.
	Free-run timer	3 ch.
	Output compare	6 ch.
	Waveform generator	3 ch.
	PPG	3 ch.
		1 unit (Max)
QPRC		1 ch. (Max)
Dual Timer		1 unit
Real-time clock		1 unit
Watch Counter		1 unit
CRC Accelerator		Yes
Watchdog timer		1 ch. (SW) + 1 ch. (HW)
External Interrupts		6 pins (Max) + NMI × 1
General Purpose I/O ports		36 pins (Max)
12-bit A/D converter		8 ch. (2 units)
CSV (Clock Super Visor)		Yes
LVD (Low-Voltage Detector)		2 ch.
Built-in OSC	High-speed	4 MHz
	Low-speed	100 kHz
Debug Function		SWJ-DP

#### Note:

- All signals of the peripheral function in each product cannot be allocated by limiting the pins of package. It is necessary to use the port relocate function of the General I/O port according to your function use. See "12. Electrical Characteristics 12.4. AC Characteristics" for accuracy of built-in CR.



## 2. Packages

Package	Product name	MB9AF311K MB9AF312K
LQFP: LQA048 (0.5 mm pitch)		○
QFN: VNA048 (0.5 mm pitch)		○
LQFP: LQC052 (0.65 mm pitch)		○

○: Supported

**Note:**

- See "14.Package Dimensions" for detailed information on each package.

### 3. Pin Assignment

#### LQA048

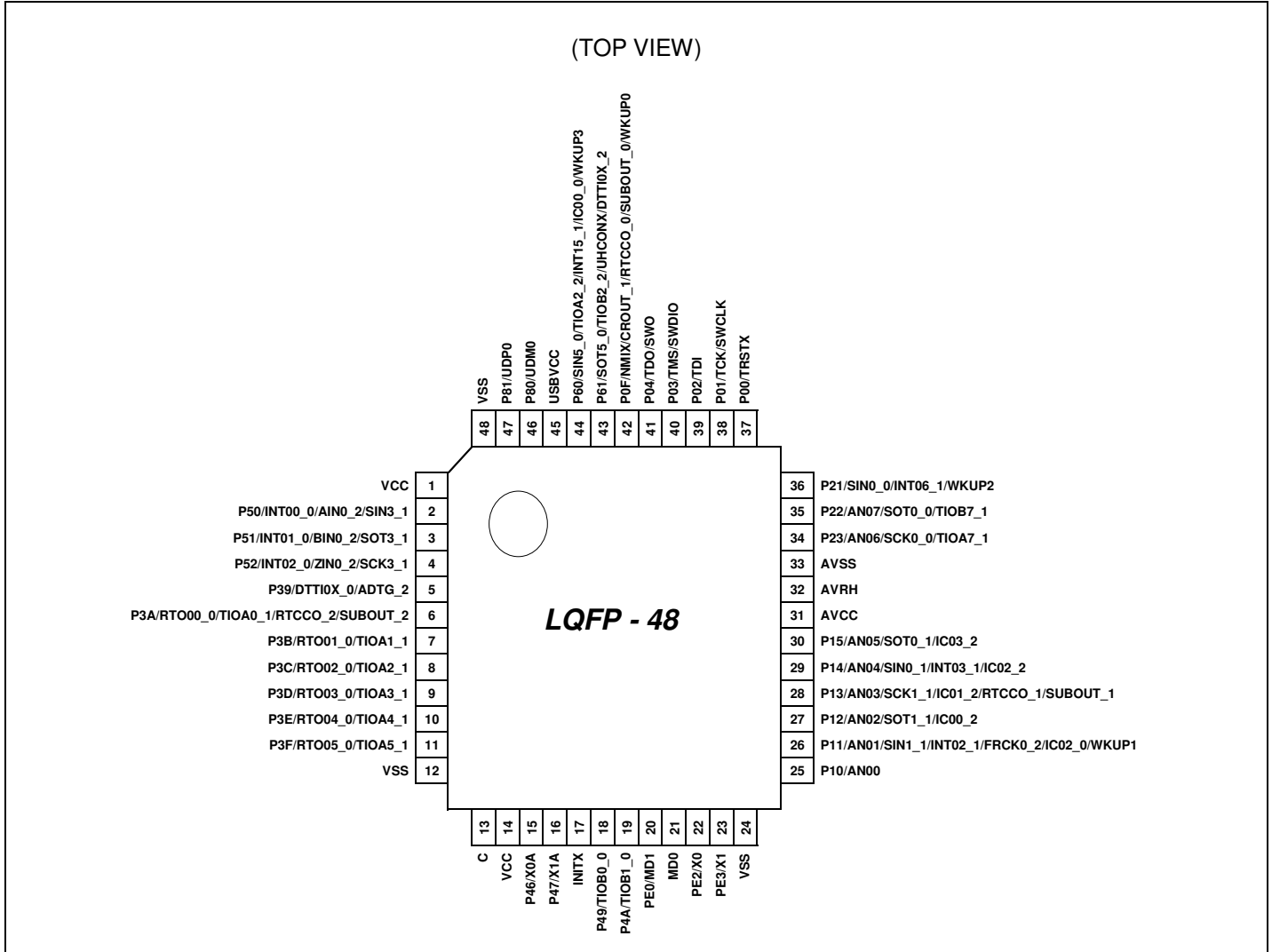

**Note:**

- The number after the underscore ("\_") in pin names such as XXX\_1 and XXX\_2 indicates the relocated port number. For these pins, there are multiple pins that provide the same function for the same channel. Use the extended port function register (EPFR) to select the pin.





#### 4. List of Pin Functions

##### List of pin numbers

The number after the underscore ("\_") in pin names such as XXX\_1 and XXX\_2 indicates the relocated port number. For these pins, there are multiple pins that provide the same function for the same channel. Use the extended port function register (EPFR) to select the pin.

Pin No		Pin Name	I/O circuit type	Pin state type
LQFP-48 QFN-48	LQFP-52			
1	1	VCC	-	
2	2	P50	I <sup>**</sup>	H
		INT00_0		
		AIN0_2		
		SIN3_1		
3	3	P51	I <sup>**</sup>	H
		INT01_0		
		BIN0_2		
		SOT3_1		
4	4	P52	I <sup>**</sup>	H
		INT02_0		
		ZIN0_2		
		SCK3_1		
-	5	NC	-	
5	6	P39	E	I
		DTTI0X_0		
		ADTG_2		
6	7	P3A	G	I
		RTO00_0		
		TIOA0_1		
		RTCCO_2		
7	8	P3B	G	I
		RTO01_0		
		TIOA1_1		
8	9	P3C	G	I
		RTO02_0		
		TIOA2_1		
9	10	P3D	G	I
		RTO03_0		
		TIOA3_1		
10	11	P3E	G	I
		RTO04_0		
		TIOA4_1		
11	12	P3F	G	I
		RTO05_0		
		TIOA5_1		

Pin No		Pin Name	I/O circuit type	Pin state type
LQFP-48 QFN-48	LQFP-52			
12	13	VSS	-	
13	14	C	-	
14	15	VCC	-	
15	16	P46	D	M
		X0A		
16	17	P47	D	N
		X1A		
17	18	INITX	B	C
18	19	P49	E	I
		TIOB0_0		
19	20	P4A	E	I
		TIOB1_0		
-	21	NC	-	
20	22	PE0	C	P
		MD1		
21	23	MD0	J	D
22	24	PE2	A	A
		X0		
23	25	PE3	A	B
		X1		
24	26	VSS	-	
25	27	P10	F	K
		AN00		
26	28	P11	F	F
		AN01		
		SIN1_1		
		INT02_1		
		FRCK0_2		
		IC02_0		
27	29	WKUP1	F	K
		P12		
		AN02		
		SOT1_1		
28	30	IC00_2	F	K
		P13		
		AN03		
		SCK1_1		
		IC01_2		
		RTCCO_1		
SUBOUT_1				

Pin No		Pin Name	I/O circuit type	Pin state type
LQFP-48 QFN-48	LQFP-52			
29	31	P14	F	L
		AN04		
		SIN0_1		
		INT03_1		
		IC02_2		
30	32	P15	F	K
		AN05		
		SOT0_1		
		IC03_2		
31	33	AVCC	-	
32	34	AVRH	-	
33	35	AVSS	-	
-	36	NC	-	
34	37	P23	F	K
		AN06		
		SCK0_0		
		TIOA7_1		
35	38	P22	F	K
		AN07		
		SOT0_0		
		TIOB7_1		
36	39	P21	E	G
		SIN0_0		
		INT06_1		
		WKUP2		
-	40	NC	-	
37	41	P00	E	E
		TRSTX		
38	42	P01	E	E
		TCK		
		SWCLK		
39	43	P02	E	E
		TDI		
40	44	P03	E	E
		TMS		
		SWDIO		
41	45	P04	E	E
		TDO		
		SWO		
42	46	P0F	E	J
		NMIX		
		CROUT_1		
		RTCCO_0		
		SUBOUT_0		
		WKUP0		

Pin No		Pin Name	I/O circuit type	Pin state Type
LQFP-48 QFN-48	LQFP-52			
43	47	P61	E	I
		SOT5_0		
		TIOB2_2		
		UHCONX		
		DTTI0X_2		
44	48	P60	I*1	G
		SIN5_0		
		TIOA2_2		
		INT15_1		
		IC00_0		
		WKUP3		
45	49	USBVCC	-	
46	50	P80	H	O
		UDM0		
47	51	P81	H	O
		UDP0		
48	52	VSS	-	

\*1: 5V tolerant I/O



**List of pin functions**

The number after the underscore ("\_") in pin names such as XXX\_1 and XXX\_2 indicates the relocated port number. For these pins, there are multiple pins that provide the same function for the same channel. Use the extended port function register (EPFR) to select the pin.

Module	Pin name	Function	Pin No	
			LQFP-48 QFN-48	LQFP-52
ADC	ADTG_2	A/D converter external trigger input pin	5	6
	AN00	A/D converter analog input pin. ANxx describes ADC ch.xx.	25	27
	AN01		26	28
	AN02		27	29
	AN03		28	30
	AN04		29	31
	AN05		30	32
	AN06		34	37
AN07	35		38	
Base Timer 0	TIOA0_1	Base timer ch.0 TIOA pin	6	7
	TIOB0_0	Base timer ch.0 TIOB pin	18	19
Base Timer 1	TIOA1_1	Base timer ch.1 TIOA pin	7	8
	TIOB1_0	Base timer ch.1 TIOB pin	19	20
Base Timer 2	TIOA2_1	Base timer ch.2 TIOA pin	8	9
	TIOA2_2		44	48
	TIOB2_2	Base timer ch.2 TIOB pin	43	47
Base Timer 3	TIOA3_1	Base timer ch.3 TIOA pin	9	10
Base Timer 4	TIOA4_1	Base timer ch.4 TIOA pin	10	11
Base Timer 5	TIOA5_1	Base timer ch.5 TIOA pin	11	12
Base Timer 7	TIOA7_1	Base timer ch.7 TIOA pin	34	37
	TIOB7_1	Base timer ch.7 TIOB pin	35	38
Debugger	SWCLK	Serial wire debug interface clock input pin	38	42
	SWDIO	Serial wire debug interface data input/output pin	40	44
	SWO	Serial wire viewer output pin	41	45
	TCK	JTAG test clock input pin	38	42
	TDI	JTAG test data input pin	39	43
	TDO	JTAG debug data output pin	41	45
	TMS	JTAG test mode state input/output pin	40	44
	TRSTX	JTAG test reset Input pin	37	41
External Interrupt	INT00_0	External interrupt request 00 input pin	2	2
	INT01_0	External interrupt request 01 input pin	3	3
	INT02_0	External interrupt request 02 input pin	4	4
	INT02_1		26	28
	INT03_1	External interrupt request 03 input pin	29	31
	INT06_1	External interrupt request 06 input pin	36	39
	INT15_1	External interrupt request 15 input pin	44	48
	NMIX	Non-Maskable Interrupt input pin	42	46

Module	Pin name	Function	Pin No	
			LQFP-48 QFN-48	LQFP-52
GPIO	P00	General-purpose I/O port 0	37	41
	P01		38	42
	P02		39	43
	P03		40	44
	P04		41	45
	P0F		42	46
	P10	General-purpose I/O port 1	25	27
	P11		26	28
	P12		27	29
	P13		28	30
	P14		29	31
	P15		30	32
	P21	General-purpose I/O port 2	36	39
	P22		35	38
	P23		34	37
	P39	General-purpose I/O port 3	5	6
	P3A		6	7
	P3B		7	8
	P3C		8	9
	P3D		9	10
	P3E		10	11
	P3F	General-purpose I/O port 4	11	12
	P46		15	16
	P47		16	17
	P49		18	19
	P4A	General-purpose I/O port 5	19	20
	P50		2	2
	P51	General-purpose I/O port 5	3	3
	P52		4	4
	P60	General-purpose I/O port 6	44	48
	P61		43	47
	P80	General-purpose I/O port 8	46	50
P81	47		51	
PE0	General-purpose I/O port E	20	22	
PE2		22	24	
PE3		23	25	

Module	Pin name	Function	Pin No.	
			LQFP-48 QFN-48	LQFP-52
Multi- function Serial 0	SIN0_0	Multi-function serial interface ch.0 input pin	36	39
	SIN0_1		29	31
	SOT0_0 (SDA0_0)	Multi-function serial interface ch.0 output pin. This pin operates as SOT0 when it is used in a UART/CSIO/LIN (operation modes 0 to 3) and as SDA0 when it is used in an I <sup>2</sup> C (operation mode 4).	35	38
	SOT0_1 (SDA0_1)		30	32
	SCK0_0 (SCL0_0)	Multi-function serial interface ch.0 clock I/O pin. This pin operates as SCK0 when it is used in a CSIO (operation modes 2) and as SCL0 when it is used in an I <sup>2</sup> C (operation mode 4).	34	37
Multi- function Serial 1	SIN1_1	Multi-function serial interface ch.1 input pin	26	28
	SOT1_1 (SDA1_1)	Multi-function serial interface ch.1 output pin. This pin operates as SOT1 when it is used in a UART/CSIO/LIN (operation modes 0 to 3) and as SDA1 when it is used in an I <sup>2</sup> C (operation mode 4).	27	29
	SCK1_1 (SCL1_1)	Multi-function serial interface ch.1 clock I/O pin. This pin operates as SCK1 when it is used in a CSIO (operation modes 2) and as SCL1 when it is used in an I <sup>2</sup> C (operation mode 4).	28	30
Multi- function Serial 3	SIN3_1	Multi-function serial interface ch.3 input pin	2	2
	SOT3_1 (SDA3_1)	Multi-function serial interface ch.3 output pin. This pin operates as SOT3 when it is used in a UART/CSIO/LIN (operation modes 0 to 3) and as SDA3 when it is used in an I <sup>2</sup> C (operation mode 4).	3	3
	SCK3_1 (SCL3_1)	Multi-function serial interface ch.3 clock I/O pin. This pin operates as SCK3 when it is used in a CSIO (operation modes 2) and as SCL3 when it is used in an I <sup>2</sup> C (operation mode 4).	4	4
Multi- function Serial 5	SIN5_0	Multi-function serial interface ch.5 input pin	44	48
	SOT5_0	Multi-function serial interface ch.5 output pin. This pin operates as SOT5 when it is used in a UART/LIN (operation modes 0, 1, 3).	43	47

Module	Pin name	Function	Pin No	
			LQFP-48 QFN-48	LQFP-52
Multi- function Timer 0	DTTI0X_0	Input signal controlling wave form generator outputs RTO00 to RTO05 of multi-function timer 0.	5	6
	DTTI0X_2		43	47
	FRCK0_2	16-bit free-run timer ch.0 external clock input pin	26	28
	IC00_0	16-bit input capture ch.0 input pin of multi-function timer 0. ICxx describes channel number.	44	48
	IC00_2		27	29
	IC01_2		28	30
	IC02_0		26	28
	IC02_2		29	31
	IC03_2		30	32
	RTO00_0 (PPG00_0)	Wave form generator output pin of multi-function timer 0. This pin operates as PPG00 when it is used in PPG0 output modes.	6	7
	RTO01_0 (PPG00_0)	Wave form generator output pin of multi-function timer 0. This pin operates as PPG00 when it is used in PPG0 output modes.	7	8
	RTO02_0 (PPG02_0)	Wave form generator output pin of multi-function timer 0. This pin operates as PPG02 when it is used in PPG0 output modes.	8	9
	RTO03_0 (PPG02_0)	Wave form generator output pin of multi-function timer 0. This pin operates as PPG02 when it is used in PPG0 output modes.	9	10
	RTO04_0 (PPG04_0)	Wave form generator output pin of multi-function timer 0. This pin operates as PPG04 when it is used in PPG0 output modes.	10	11
RTO05_0 (PPG04_0)	Wave form generator output pin of multi-function timer 0. This pin operates as PPG04 when it is used in PPG0 output modes.	11	12	
Quadrature Position/ Revolution Counter 0	AIN0_2	QPRC ch.0 AIN input pin	2	2
	BIN0_2	QPRC ch.0 BIN input pin	3	3
	ZIN0_2	QPRC ch.0 ZIN input pin	4	4
Real-time clock	RTCCO_0	0.5 seconds pulse output pin of Real-time clock	42	46
	RTCCO_1		28	30
	RTCCO_2		6	7
	SUBOUT_0	Sub clock output pin	42	46
	SUBOUT_1		28	30
	SUBOUT_2		6	7
Low Power Consumption Mode	WKUP0	Deep stand-by mode return signal input pin 0	42	46
	WKUP1	Deep stand-by mode return signal input pin 1	26	28
	WKUP2	Deep stand-by mode return signal input pin 2	36	39
	WKUP3	Deep stand-by mode return signal input pin 3	44	48
USB	UDM0	USB ch.0 device/host D – pin	46	50
	UDP0	USB ch.0 device/host D + pin	47	51
	UHCONX	USB external pull-up control pin	43	47

Module	Pin name	Function	Pin No	
			LQFP-48 QFN-48	LQFP-52
Reset	INITX	External Reset Input pin. A reset is valid when INITX = "L".	17	18
Mode	MD0	Mode 0 pin. During normal operation, MD0 = "L" must be input. During serial programming to Flash memory, MD0 = "H" must be input.	21	23
	MD1	Mode 1 pin. During serial programming to Flash memory, MD1 = "L" must be input.	20	22
Power	VCC	Power supply Pin	1	1
	VCC	Power supply Pin	14	15
	USBVCC	3.3V Power supply port for USB I/O	45	49
GND	VSS	GND Pin	12	13
	VSS	GND Pin	24	26
	VSS	GND Pin	48	52
Clock	X0	Main clock (oscillation) input pin	22	24
	X0A	Sub clock (oscillation) input pin	15	16
	X1	Main clock (oscillation) I/O pin	23	25
	X1A	Sub clock (oscillation) I/O pin	16	17
	CROUT_1	Built-in high-speed CR-osc clock output port	42	46
Analog Power	AVCC	A/D converter analog power pin	31	33
	AVRH	A/D converter analog reference voltage input pin	32	34
Analog GND	AVSS	A/D converter GND pin	33	35
C pin	C	Power stabilization capacity pin	13	14
NC pin	NC	NC pin. NC pin should be kept open.	-	5
	NC	NC pin. NC pin should be kept open.	-	21
	NC	NC pin. NC pin should be kept open.	-	36
	NC	NC pin. NC pin should be kept open.	-	40

**Note:**

- While this device contains a Test Access Port (TAP) based on the IEEE 1149.1-2001 JTAG standard, it is not fully compliant to all requirements of that standard. This device may contain a 32-bit device ID that is the same as the 32-bit device ID in other devices with different functionality. The TAP pins may also be configurable for purposes other than access to the TAP controller.

**5. I/O Circuit Type**

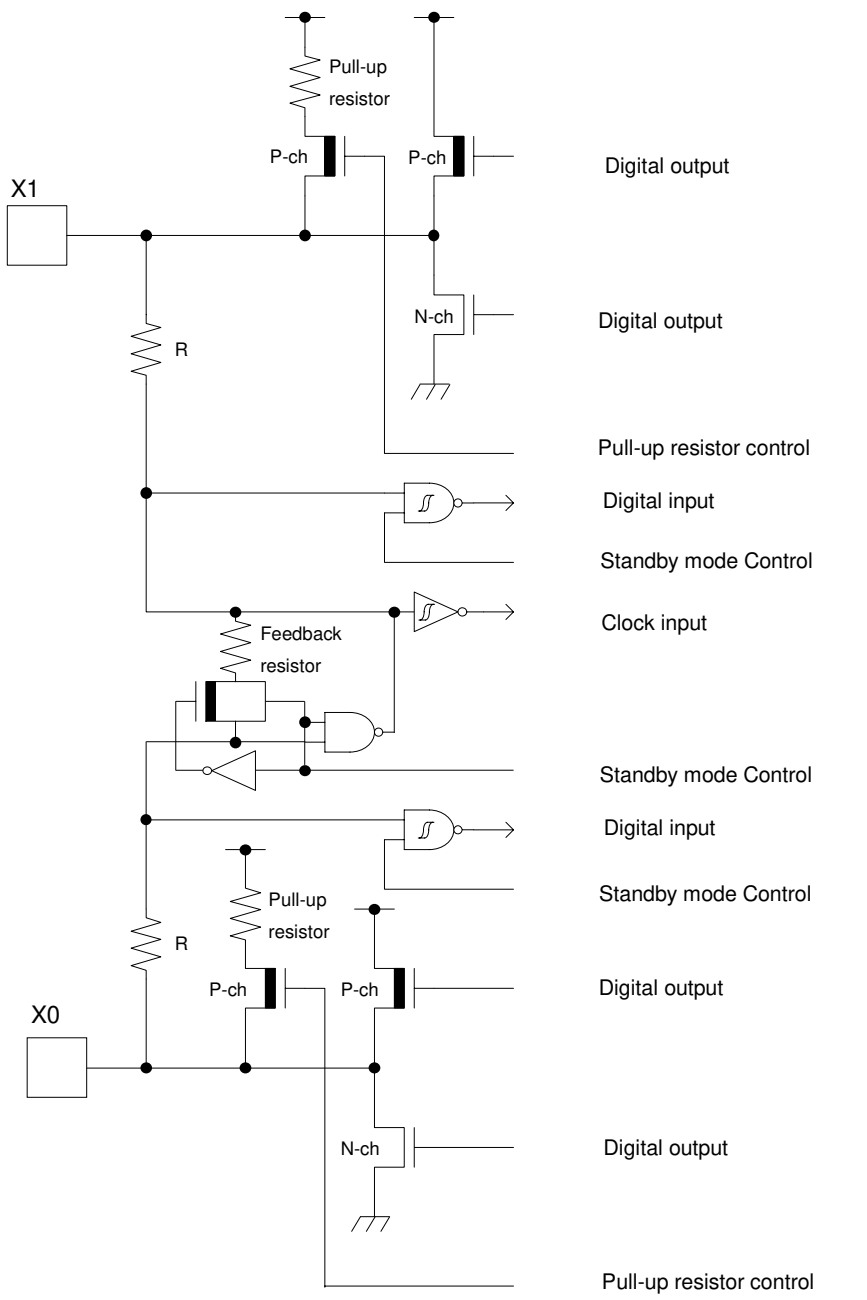
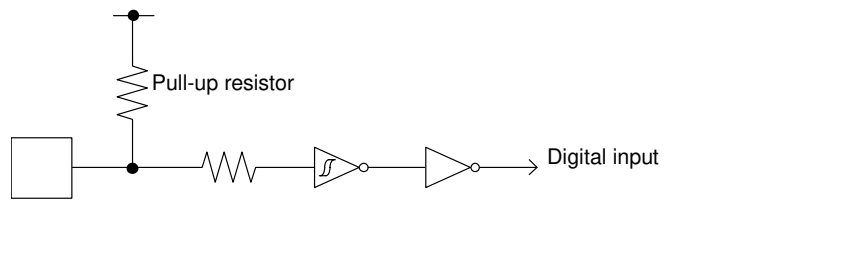
Type	Circuit	Remarks
A		<p>It is possible to select the main oscillation / GPIO function</p> <p>When the main oscillation is selected.</p> <ul style="list-style-type: none"> <li>- Oscillation feedback resistor : Approximately 1 MΩ</li> <li>- With Standby mode control</li> </ul> <p>When the GPIO is selected.</p> <ul style="list-style-type: none"> <li>- CMOS level output.</li> <li>- CMOS level hysteresis input</li> <li>- With pull-up resistor control</li> <li>- With standby mode control</li> <li>- Pull-up resistor: Approximately 50 kΩ</li> <li>- <math>I_{OH} = -4 \text{ mA}</math>, <math>I_{OL} = 4 \text{ mA}</math></li> </ul>
B		<ul style="list-style-type: none"> <li>- CMOS level hysteresis input</li> <li>- Pull-up resistor : Approximately 50 kΩ</li> </ul>

Type	Circuit	Remarks
C		<ul style="list-style-type: none"> <li>- Open drain output</li> <li>- CMOS level hysteresis input</li> </ul>
D		<p>It is possible to select the sub oscillation / GPIO function</p> <p>When the sub oscillation is selected.</p> <ul style="list-style-type: none"> <li>- Oscillation feedback resistor : Approximately 5 MΩ</li> <li>- With Standby mode control</li> </ul> <p>When the GPIO is selected.</p> <ul style="list-style-type: none"> <li>- CMOS level output.</li> <li>- CMOS level hysteresis input</li> <li>- With pull-up resistor control</li> <li>- With standby mode control</li> <li>- Pull-up resistor : Approximately 50 kΩ</li> <li>- <math>I_{OH} = -4 \text{ mA}</math>, <math>I_{OL} = 4 \text{ mA}</math></li> </ul>

Type	Circuit	Remarks
E	<p>The circuit diagram for Type E shows a digital pin configuration. It includes a pull-up resistor R connected to a supply voltage. A P-channel MOSFET (P-ch) is connected to the supply voltage and the pin. An N-channel MOSFET (N-ch) is connected to the pin and ground. The P-ch transistor's gate is connected to the pin through a pull-up resistor. The N-ch transistor's gate is connected to the pin through a pull-up resistor. The P-ch transistor's drain is connected to the supply voltage, and the N-ch transistor's drain is connected to ground. The digital output is taken from the pin. A digital input is connected to the pin through a pull-up resistor. A standby mode control input is connected to the pin through a pull-up resistor.</p>	<ul style="list-style-type: none"> <li>- CMOS level output</li> <li>- CMOS level hysteresis input</li> <li>- With pull-up resistor control</li> <li>- With standby mode control</li> <li>- Pull-up resistor : Approximately 50 kΩ</li> <li>- <math>I_{OH} = -4 \text{ mA}</math>, <math>I_{OL} = 4 \text{ mA}</math></li> <li>- When this pin is used as an I2C pin, the digital output P-ch transistor is always off</li> <li>- +B input is available</li> </ul>
F	<p>The circuit diagram for Type F shows a digital pin configuration with additional analog input capabilities. It includes a pull-up resistor R connected to a supply voltage. A P-channel MOSFET (P-ch) is connected to the supply voltage and the pin. An N-channel MOSFET (N-ch) is connected to the pin and ground. The P-ch transistor's gate is connected to the pin through a pull-up resistor. The N-ch transistor's gate is connected to the pin through a pull-up resistor. The P-ch transistor's drain is connected to the supply voltage, and the N-ch transistor's drain is connected to ground. The digital output is taken from the pin. A digital input is connected to the pin through a pull-up resistor. A standby mode control input is connected to the pin through a pull-up resistor. An analog input is connected to the pin through a pull-up resistor. An input control input is connected to the pin through a pull-up resistor.</p>	<ul style="list-style-type: none"> <li>- CMOS level output</li> <li>- CMOS level hysteresis input</li> <li>- With input control</li> <li>- Analog input</li> <li>- With pull-up resistor control</li> <li>- With standby mode control</li> <li>- Pull-up resistor : Approximately 50 kΩ</li> <li>- <math>I_{OH} = -4 \text{ mA}</math>, <math>I_{OL} = 4 \text{ mA}</math></li> <li>- When this pin is used as an I2C pin, the digital output P-ch transistor is always off</li> <li>- +B input is available</li> </ul>

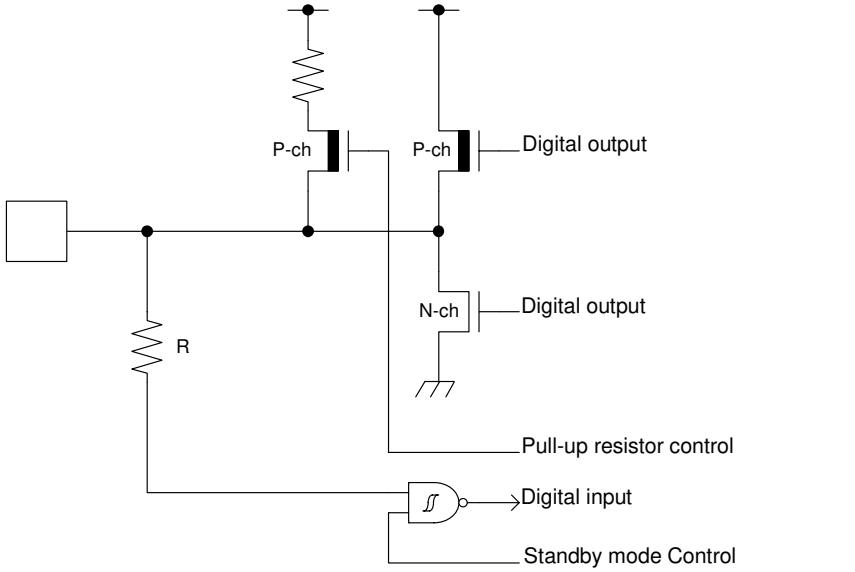
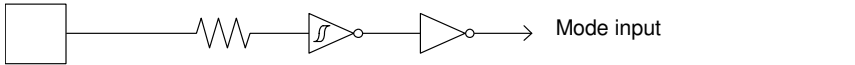

Type	Circuit	Remarks
G	<p>The diagram shows a digital output stage. It features a pull-up resistor <math>R</math> connected to a supply rail. The output node is driven by a P-channel MOSFET (P-ch) and an N-channel MOSFET (N-ch). The P-ch MOSFET's gate is controlled by a 'Pull-up resistor control' signal. The N-ch MOSFET's gate is controlled by a 'Standby mode Control' signal. The output node is also connected to a 'Digital input' through an inverter.</p>	<ul style="list-style-type: none"> <li>- CMOS level output</li> <li>- CMOS level hysteresis input</li> <li>- With pull-up resistor control</li> <li>- With standby mode control</li> <li>- Pull-up resistor : Approximately 50 k<math>\Omega</math></li> <li>- <math>I_{OH} = -12 \text{ mA}</math>, <math>I_{OL} = 12 \text{ mA}</math></li> <li>- +B input is available</li> </ul>
H	<p>The diagram illustrates a complex digital interface circuit. It includes several input and output blocks: <ul style="list-style-type: none"> <li><b>GPIO Digital output</b>: A buffer stage.</li> <li><b>GPIO Digital input/output direction</b>: A control signal for the GPIO output.</li> <li><b>GPIO Digital input</b>: An input signal.</li> <li><b>GPIO Digital input circuit control</b>: A control signal for the GPIO input.</li> <li><b>UDP output</b>: A buffer stage.</li> <li><b>USB Full-speed/Low-speed control</b>: A control signal.</li> <li><b>UDP input</b>: An input signal.</li> <li><b>Differential input</b>: A differential input stage.</li> <li><b>USB/GPIO select</b>: A control signal.</li> <li><b>UDM input</b>: An input signal.</li> <li><b>UDM output</b>: A buffer stage.</li> <li><b>USB Digital input/output direction</b>: A control signal.</li> <li><b>GPIO Digital input</b>: An input signal.</li> <li><b>GPIO Digital input/output direction</b>: A control signal.</li> <li><b>GPIO Digital input circuit control</b>: A control signal.</li> </ul> </p>	<p>It is possible to select the USB I/O / GPIO function. When the USB I/O is selected.</p> <ul style="list-style-type: none"> <li>- Full-speed, Low-speed control</li> </ul> <p>When the GPIO is selected.</p> <ul style="list-style-type: none"> <li>- CMOS level output</li> <li>- CMOS level hysteresis input</li> <li>- With standby mode control</li> <li><math>I_{OH} = -20.5 \text{ mA}</math>, <math>I_{OL} = 18.5 \text{ mA}</math></li> </ul>

Type	Circuit	Remarks
I	 <p>The diagram shows a pull-up resistor R connected to a node. This node is connected to the gates of two P-channel MOSFETs (P-ch) and the gate of one N-channel MOSFET (N-ch). One P-ch MOSFET is connected to a Digital output. The N-ch MOSFET is connected to ground and also to a Digital output. The gates of the P-ch MOSFETs are also connected to a Digital input through an inverter. The gates of both P-ch MOSFETs are connected to a Standby mode Control input through an inverter. The gates of both P-ch MOSFETs are also connected to a Pull-up resistor control input through an inverter.</p>	<ul style="list-style-type: none"> <li>- CMOS level output</li> <li>- CMOS level hysteresis input</li> <li>- 5V tolerant</li> <li>- With pull-up resistor control</li> <li>- With standby mode control</li> <li>- Pull-up resistor : Approximately 50 kΩ</li> <li>- <math>I_{OH} = -4 \text{ mA}</math>, <math>I_{OL} = 4 \text{ mA}</math></li> <li>- Available to control of PZR registers.</li> </ul>
J	 <p>The diagram shows a resistor connected to a Mode input through two inverters in series.</p>	<ul style="list-style-type: none"> <li>- CMOS level hysteresis input</li> </ul>

## 6. Handling Precautions

Any semiconductor devices have inherently a certain rate of failure. The possibility of failure is greatly affected by the conditions in which they are used (circuit conditions, environmental conditions, etc.). This page describes precautions that must be observed to minimize the chance of failure and to obtain higher reliability from your Cypress semiconductor devices.

### 6.1 Precautions for Product Design

This section describes precautions when designing electronic equipment using semiconductor devices.

#### Absolute Maximum Ratings

Semiconductor devices can be permanently damaged by application of stress (voltage, current, temperature, etc.) in excess of certain established limits, called absolute maximum ratings. Do not exceed these ratings.

#### Recommended Operating Conditions

Recommended operating conditions are normal operating ranges for the semiconductor device. All the device's electrical characteristics are warranted when operated within these ranges.

Always use semiconductor devices within the recommended operating conditions. Operation outside these ranges may adversely affect reliability and could result in device failure.

No warranty is made with respect to uses, operating conditions, or combinations not represented on the Datasheet. Users considering application outside the listed conditions are advised to contact their sales representative beforehand.

#### Processing and Protection of Pins

These precautions must be followed when handling the pins which connect semiconductor devices to power supply and input/output functions.

1. Preventing Over-Voltage and Over-Current Conditions

Exposure to voltage or current levels in excess of maximum ratings at any pin is likely to cause deterioration within the device, and in extreme cases leads to permanent damage of the device. Try to prevent such overvoltage or over-current conditions at the design stage.

2. Protection of Output Pins

Shorting of output pins to supply pins or other output pins, or connection to large capacitance can cause large current flows. Such conditions if present for extended periods of time can damage the device. Therefore, avoid this type of connection.

3. Handling of Unused Input Pins

Unconnected input pins with very high impedance levels can adversely affect stability of operation. Such pins should be connected through an appropriate resistance to a power supply pin or ground pin.

#### Latch-up

Semiconductor devices are constructed by the formation of P-type and N-type areas on a substrate. When subjected to abnormally high voltages, internal parasitic PNP junctions (called thyristor structures) may be formed, causing large current levels in excess of several hundred mA to flow continuously at the power supply pin. This condition is called latch-up.

**CAUTION:** The occurrence of latch-up not only causes loss of reliability in the semiconductor device, but can cause injury or damage from high heat, smoke or flame. To prevent this from happening, do the following:

1. Be sure that voltages applied to pins do not exceed the absolute maximum ratings. This should include attention to abnormal noise, surge levels, etc.
2. Be sure that abnormal current flows do not occur during the power-on sequence.

#### Observance of Safety Regulations and Standards

Most countries in the world have established standards and regulations regarding safety, protection from electromagnetic interference, etc. Customers are requested to observe applicable regulations and standards in the design of products.

#### Fail-Safe Design

Any semiconductor devices have inherently a certain rate of failure. You must protect against injury, damage or loss from such failures by incorporating safety design measures into your facility and equipment such as redundancy, fire protection, and prevention of over-current levels and other abnormal operating conditions.

## Precautions Related to Usage of Devices

Cypress semiconductor devices are intended for use in standard applications (computers, office automation and other office equipment, industrial, communications, and measurement equipment, personal or household devices, etc.).

**CAUTION:** Customers considering the use of our products in special applications where failure or abnormal operation may directly affect human lives or cause physical injury or property damage, or where extremely high levels of reliability are demanded (such as aerospace systems, atomic energy controls, sea floor repeaters, vehicle operating controls, medical devices for life support, etc.) are requested to consult with sales representatives before such use. The company will not be responsible for damages arising from such use without prior approval.

## 6.2 Precautions for Package Mounting

Package mounting may be either lead insertion type or surface mount type. In either case, for heat resistance during soldering, you should only mount under Cypress recommended conditions. For detailed information about mount conditions, contact your sales representative.

### Lead Insertion Type

Mounting of lead insertion type packages onto printed circuit boards may be done by two methods: direct soldering on the board, or mounting by using a socket.

Direct mounting onto boards normally involves processes for inserting leads into through-holes on the board and using the flow soldering (wave soldering) method of applying liquid solder. In this case, the soldering process usually causes leads to be subjected to thermal stress in excess of the absolute ratings for storage temperature. Mounting processes should conform to Cypress recommended mounting conditions.

If socket mounting is used, differences in surface treatment of the socket contacts and IC lead surfaces can lead to contact deterioration after long periods. For this reason it is recommended that the surface treatment of socket contacts and IC leads be verified before mounting.

### Surface Mount Type

Surface mount packaging has longer and thinner leads than lead-insertion packaging, and therefore leads are more easily deformed or bent. The use of packages with higher pin counts and narrower pin pitch results in increased susceptibility to open connections caused by deformed pins, or shorting due to solder bridges.

You must use appropriate mounting techniques. Cypress recommends the solder reflow method, and has established a ranking of mounting conditions for each product. Users are advised to mount packages in accordance with Cypress ranking of recommended conditions.

### Lead-Free Packaging

**CAUTION:** When ball grid array (BGA) packages with Sn-Ag-Cu balls are mounted using Sn-Pb eutectic soldering, junction strength may be reduced under some conditions of use.

## Storage of Semiconductor Devices

Because plastic chip packages are formed from plastic resins, exposure to natural environmental conditions will cause absorption of moisture. During mounting, the application of heat to a package that has absorbed moisture can cause surfaces to peel, reducing moisture resistance and causing packages to crack. To prevent, do the following:

1. Avoid exposure to rapid temperature changes, which cause moisture to condense inside the product. Store products in locations where temperature changes are slight.
2. Use dry boxes for product storage. Products should be stored below 70% relative humidity, and at temperatures between 5°C and 30°C.  
When you open Dry Package that recommends humidity 40% to 70% relative humidity.
3. When necessary, Cypress packages semiconductor devices in highly moisture-resistant aluminum laminate bags, with a silica gel desiccant. Devices should be sealed in their aluminum laminate bags for storage.
4. Avoid storing packages where they are exposed to corrosive gases or high levels of dust.

**Baking**

Packages that have absorbed moisture may be de-moisturized by baking (heat drying). Follow the Cypress recommended conditions for baking.

Condition: 125°C/24 h

**Static Electricity**

Because semiconductor devices are particularly susceptible to damage by static electricity, you must take the following precautions:

1. Maintain relative humidity in the working environment between 40% and 70%. Use of an apparatus for ion generation may be needed to remove electricity.
2. Electrically ground all conveyors, solder vessels, soldering irons and peripheral equipment.
3. Eliminate static body electricity by the use of rings or bracelets connected to ground through high resistance (on the level of 1 MΩ).  
Wearing of conductive clothing and shoes, use of conductive floor mats and other measures to minimize shock loads is recommended.
4. Ground all fixtures and instruments, or protect with anti-static measures.
5. Avoid the use of styrofoam or other highly static-prone materials for storage of completed board assemblies.

**6.3 Precautions for Use Environment**

Reliability of semiconductor devices depends on ambient temperature and other conditions as described above.

For reliable performance, do the following:

1. Humidity  
Prolonged use in high humidity can lead to leakage in devices as well as printed circuit boards. If high humidity levels are anticipated, consider anti-humidity processing.
2. Discharge of Static Electricity  
When high-voltage charges exist close to semiconductor devices, discharges can cause abnormal operation. In such cases, use anti-static measures or processing to prevent discharges.
3. Corrosive Gases, Dust, or Oil  
Exposure to corrosive gases or contact with dust or oil may lead to chemical reactions that will adversely affect the device. If you use devices in such conditions, consider ways to prevent such exposure or to protect the devices.
4. Radiation, Including Cosmic Radiation  
Most devices are not designed for environments involving exposure to radiation or cosmic radiation. Users should provide shielding as appropriate.
5. Smoke, Flame  
**CAUTION:** Plastic molded devices are flammable, and therefore should not be used near combustible substances. If devices begin to smoke or burn, there is danger of the release of toxic gases.

Customers considering the use of Cypress products in other special environmental conditions should consult with sales representatives.

## 7. Handling Devices

### Power supply pins

In products with multiple VCC and VSS pins, respective pins at the same potential are interconnected within the device in order to prevent malfunctions such as latch-up. However, all of these pins should be connected externally to the power supply or ground lines in order to reduce electromagnetic emission levels, to prevent abnormal operation of strobe signals caused by the rise in the ground level, and to conform to the total output current rating.

Moreover, connect the current supply source with each Power supply pins and GND pins of this device at low impedance. It is also advisable that a ceramic capacitor of approximately 0.1  $\mu\text{F}$  be connected as a bypass capacitor between each Power supply pins and GND pins, between AVCC pin and AVSS pin near this device.

### Stabilizing power supply voltage

A malfunction may occur when the power supply voltage fluctuates rapidly even though the fluctuation is within the recommended operating conditions of the VCC power supply voltage. As a rule, with voltage stabilization, suppress the voltage fluctuation so that the fluctuation in VCC ripple (peak-to-peak value) at the commercial frequency (50 Hz/60 Hz) does not exceed 10% of the VCC value in the recommended operating conditions, and the transient fluctuation rate does not exceed 0.1 V/ $\mu\text{s}$  when there is a momentary fluctuation on switching the power supply.

### Crystal oscillator circuit

Noise near the X0/X1 and X0A/X1A pins may cause the device to malfunction. Design the printed circuit board so that X0/X1, X0A/X1A pins, the crystal oscillator (or ceramic oscillator), and the bypass capacitor to ground are located as close to the device as possible.

It is strongly recommended that the PC board artwork be designed such that the X0/X1 and X0A/X1A pins are surrounded by ground plane as this is expected to produce stable operation.

Evaluate oscillation of your using crystal oscillator by your mount board.

### Using an external clock

When using an external clock, the clock signal should be input to the X0, X0A pin only and the X1, X1A pin should be kept open.

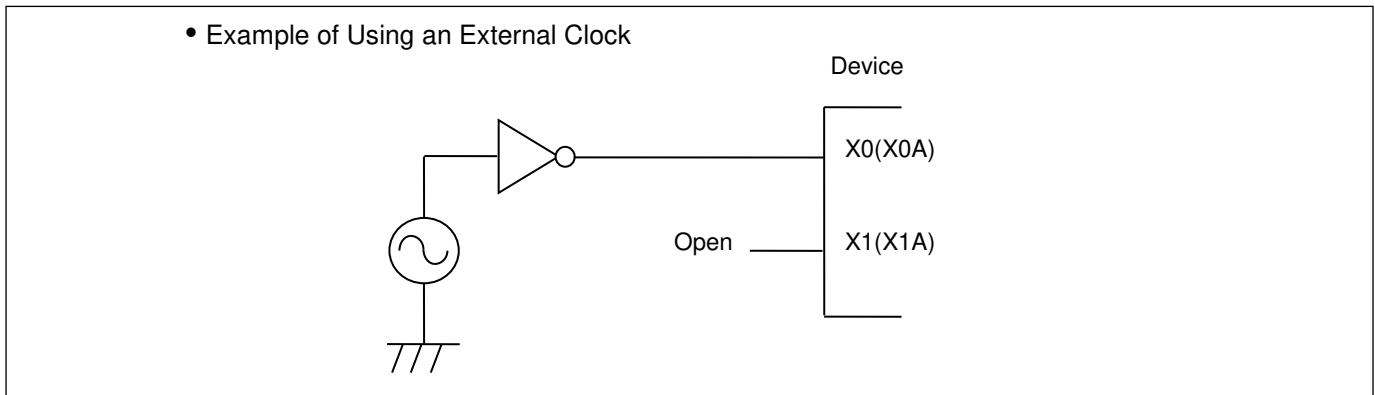

### Handling when using Multi-function serial pin as I<sup>2</sup>C pin

If it is using Multi-function serial pin as I<sup>2</sup>C pins, P-ch transistor of digital output is always disable. However, I<sup>2</sup>C pins need to keep the electrical characteristic like other pins and not to connect to external I<sup>2</sup>C bus system with power OFF.

## C pin

This series contains the regulator. Be sure to connect a smoothing capacitor ( $C_s$ ) for the regulator between the C pin and the GND pin. Please use a ceramic capacitor or a capacitor of equivalent frequency characteristics as a smoothing capacitor. However, some laminated ceramic capacitors have the characteristics of capacitance variation due to thermal fluctuation (F characteristics and Y5V characteristics). Please select the capacitor that meets the specifications in the operating conditions to use by evaluating the temperature characteristics of a capacitor. A smoothing capacitor of about 4.7  $\mu\text{F}$  would be recommended for this series.

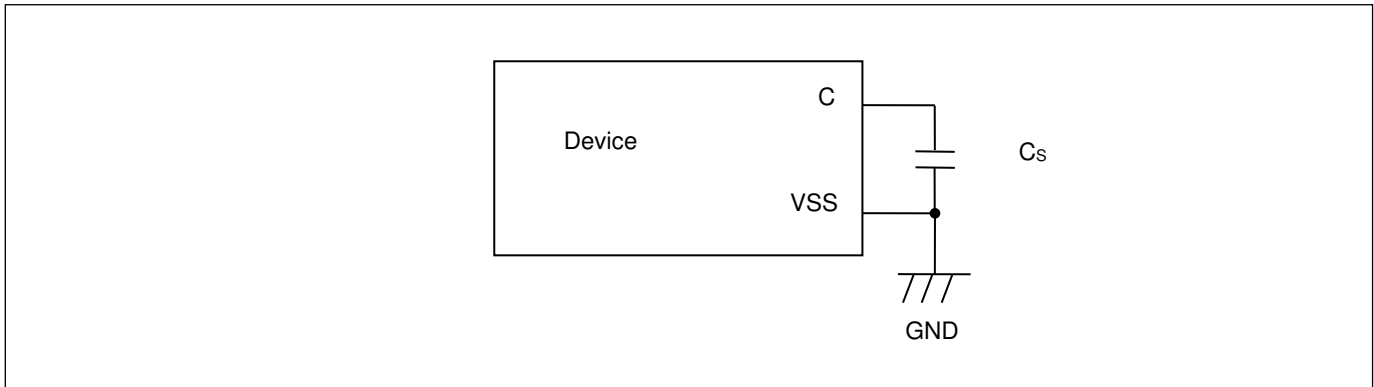

## Mode pins (MD0)

Connect the MD pin (MD0) directly to VCC or VSS pins. Design the printed circuit board such that the pull-up/down resistance stays low, as well as the distance between the mode pins and VCC pins or VSS pins is as short as possible and the connection impedance is low, when the pins are pulled-up/down such as for switching the pin level and rewriting the Flash memory data. It is because of preventing the device erroneously switching to test mode due to noise.

## NC pins

NC pin should be kept open.

## Notes on power-on

Turn power on/off in the following order or at the same time.

If not using the A/D converter, connect  $\text{AVCC} = \text{VCC}$  and  $\text{AVSS} = \text{VSS}$ .

Turning on:  $\text{VCC} \rightarrow \text{USBVCC}$   
 $\text{VCC} \rightarrow \text{AVCC} \rightarrow \text{AVRH}$

Turning off:  $\text{AVRH} \rightarrow \text{AVCC} \rightarrow \text{VCC}$   
 $\text{USBVCC} \rightarrow \text{VCC}$

## Serial Communication

There is a possibility to receive wrong data due to the noise or other causes on the serial communication.

Therefore, design a printed circuit board so as to avoid noise.

Consider the case of receiving wrong data due to noise, perform error detection such as by applying a checksum of data at the end. If an error is detected, retransmit the data.

**Differences in features among the products with different memory sizes and between Flash products and MASK products**

The electric characteristics including power consumption, ESD, latch-up, noise characteristics, and oscillation characteristics among the products with different memory sizes and between Flash products and MASK products are different because chip layout and memory structures are different.

If you are switching to use a different product of the same series, please make sure to evaluate the electric characteristics.

**Pull-Up function of 5V tolerant I/O**

Please do not input the signal more than VCC voltage at the time of Pull-Up function use of 5V tolerant I/O.



### 8. Block Diagram

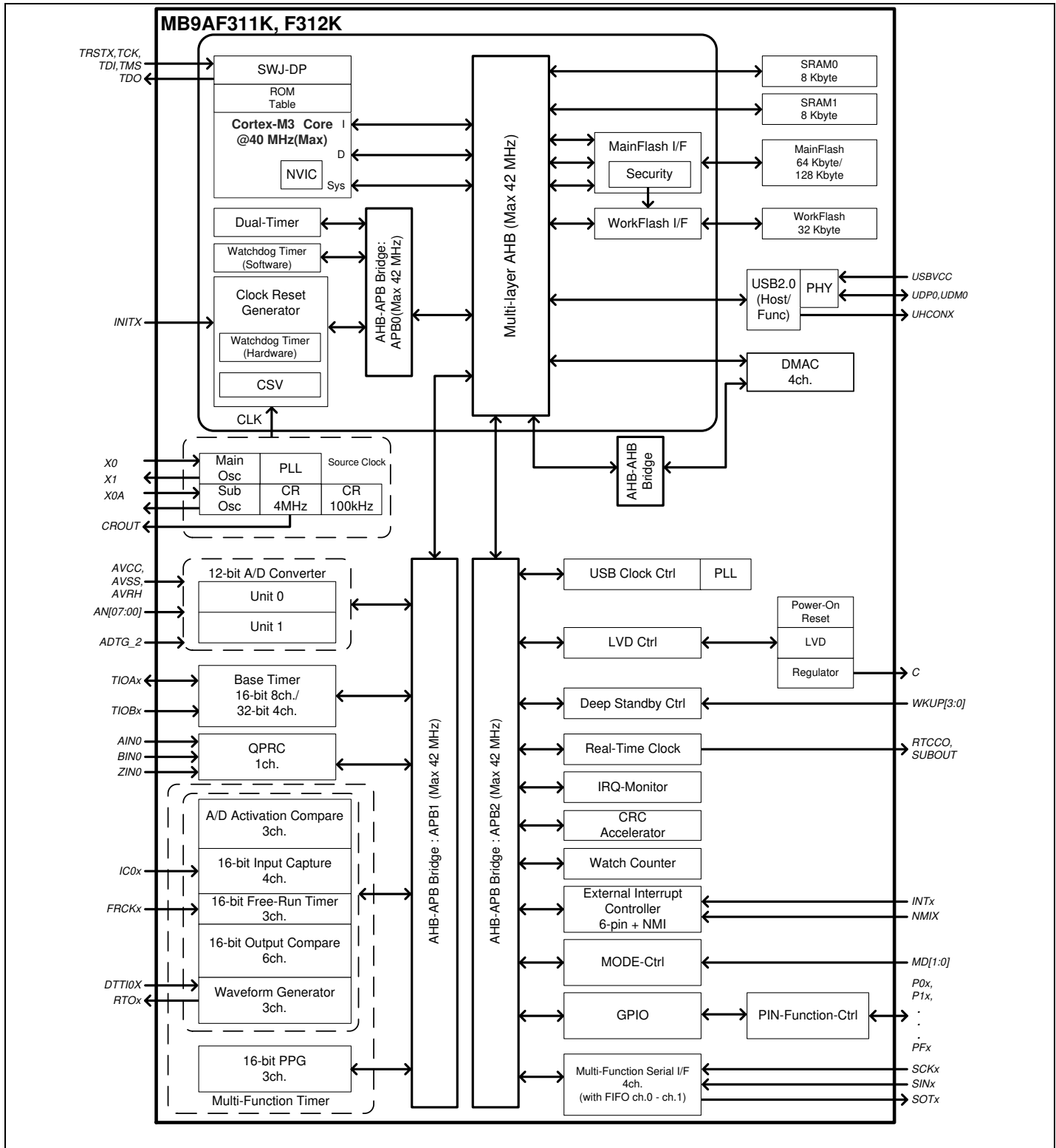

### 9. Memory Size

See "Memory size" in "0." to confirm the memory size.



## Memory Map (2)

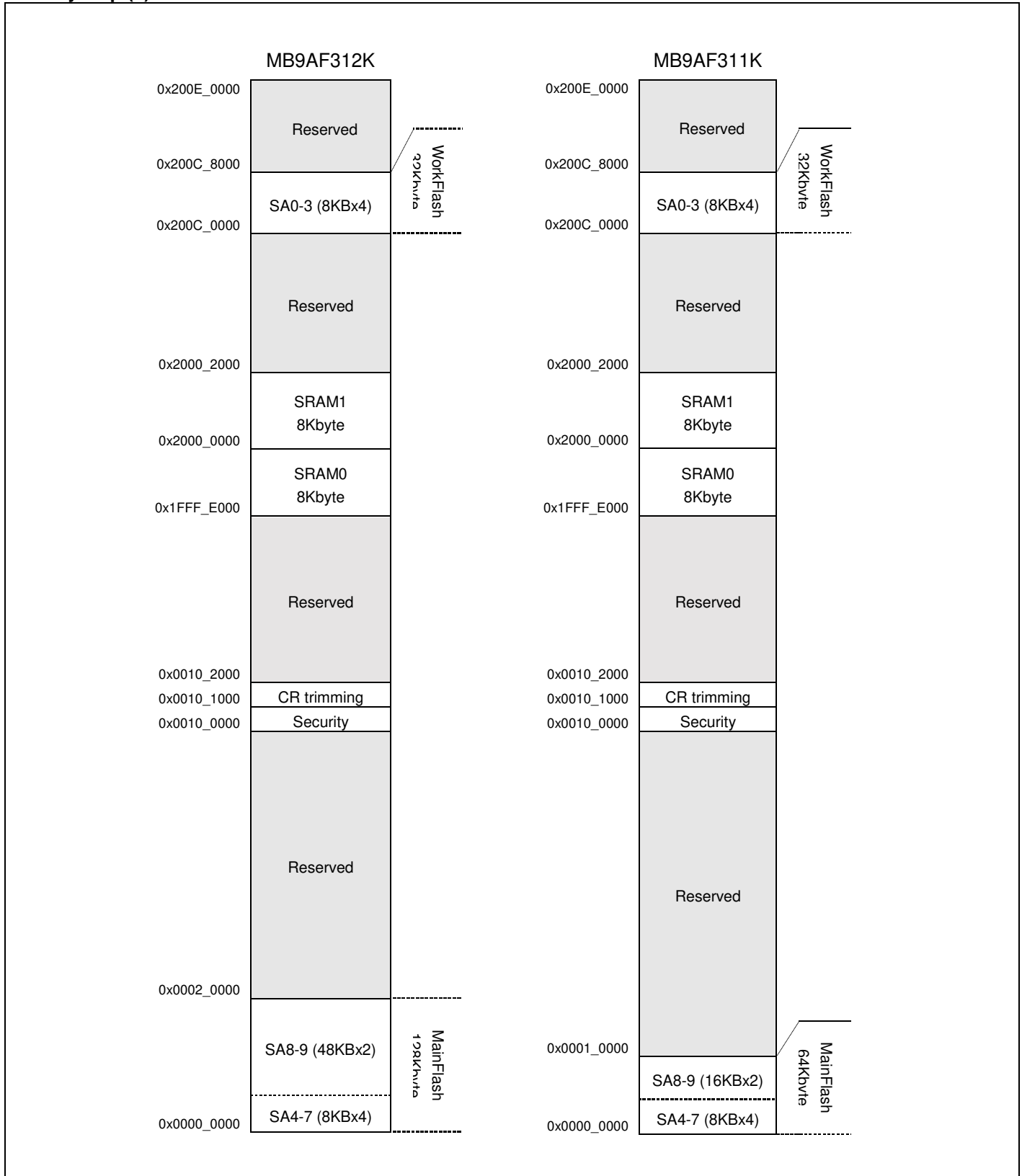

See "MB9A310K/110K Series Flash programming Manual" for sector structure of Flash.

**Peripheral Address Map**

Start address	End address	Bus	Peripherals	
0x4000_0000	0x4000_0FFF	AHB	MainFlash I/F register	
0x4000_1000	0x4000_FFFF		Reserved	
0x4001_0000	0x4001_0FFF	APB0	Clock/Reset Control	
0x4001_1000	0x4001_1FFF		Hardware Watchdog timer	
0x4001_2000	0x4001_2FFF		Software Watchdog timer	
0x4001_3000	0x4001_4FFF		Reserved	
0x4001_5000	0x4001_5FFF		Dual-Timer	
0x4001_6000	0x4001_FFFF		Reserved	
0x4002_0000	0x4002_0FFF		APB1	Multi-function timer unit0
0x4002_1000	0x4002_3FFF			Reserved
0x4002_4000	0x4002_4FFF	PPG		
0x4002_5000	0x4002_5FFF	Base Timer		
0x4002_6000	0x4002_6FFF	Quadrature Position/Revolution Counter		
0x4002_7000	0x4002_7FFF	A/D Converter		
0x4002_8000	0x4002_DFFF	Reserved		
0x4002_E000	0x4002_EFFF	Internal CR trimming		
0x4002_F000	0x4002_FFFF	Reserved		
0x4003_0000	0x4003_0FFF	APB2		External Interrupt Controller
0x4003_1000	0x4003_1FFF			Interrupt Request Batch-Read Function
0x4003_2000	0x4003_2FFF		Reserved	
0x4003_3000	0x4003_3FFF		GPIO	
0x4003_4000	0x4003_4FFF		Reserved	
0x4003_5000	0x4003_57FF		Low-Voltage Detector	
0x4003_5800	0x4003_5FFF		Deep stand-by mode Controller	
0x4003_6000	0x4003_6FFF		USB clock generator	
0x4003_7000	0x4003_7FFF		Reserved	
0x4003_8000	0x4003_8FFF		Multi-function serial Interface	
0x4003_9000	0x4003_9FFF		CRC	
0x4003_A000	0x4003_AFFF		Watch Counter	
0x4003_B000	0x4003_BFFF		Real-time clock	
0x4003_C000	0x4003_FFFF		Reserved	
0x4004_0000	0x4004_FFFF		AHB	USB ch.0
0x4005_0000	0x4005_FFFF			Reserved
0x4006_0000	0x4006_0FFF	DMAC register		
0x4006_1000	0x41FF_FFFF	Reserved		
0x200E_0000	0x200E_FFFF	WorkFlash I/F register		

## 11. Pin Status in Each CPU State

The terms used for pin status have the following meanings.

■ **INITX = 0**

This is the period when the INITX pin is the "L" level.

■ **INITX = 1**

This is the period when the INITX pin is the "H" level.

■ **SPL = 0**

This is the status that standby pin level setting bit (SPL) in standby mode control register (STB\_CTL) is set to "0".

■ **SPL = 1**

This is the status that standby pin level setting bit (SPL) in standby mode control register (STB\_CTL) is set to "1".

■ **Input enabled**

Indicates that the input function can be used.

■ **Internal input fixed at "0"**

This is the status that the input function cannot be used. Internal input is fixed at "L".

■ **Hi-Z**

Indicates that the output drive transistor is disabled and the pin is put in the Hi-Z state.

■ **Setting disabled**

Indicates that the setting is disabled.

■ **Maintain previous state**

Maintains the state that was immediately prior to entering the current mode.

If a built-in peripheral function is operating, the output follows the peripheral function.

If the pin is being used as a port, that output is maintained.

■ **Analog input is enabled**

Indicates that the analog input is enabled.

■ **GPIO selected**

In Deep stand-by mode, pins switch to the general-purpose I/O port.

**List of Pin Status**

Pin status type	Function group	Power-on reset or low-voltage detection state	INITX input state	Device internal reset state	Run mode or sleep mode state	Timer mode, RTC mode, or sleep mode state		Deep stand-by RTC mode or Deep stand-by STOP mode state		Return from Deep stand-by mode state
		Power supply unstable	Power supply stable		Power supply stable	Power supply stable		Power supply stable		Power supply stable
		-	INITX = 0	INITX = 1	INITX = 1	INITX = 1		INITX = 1		INITX = 1
		-	-	-	-	SPL = 0	SPL = 1	SPL = 0	SPL = 1	-
A	GPIO selected	Setting disabled	Setting disabled	Setting disabled	Maintain previous state	Maintain previous state	Hi-Z / Internal input fixed at "0"	Maintain previous state	Hi-Z / Internal input fixed at "0"	Maintain previous state
	Main crystal oscillator input pin	Input enabled	Input enabled	Input enabled	Input enabled	Input enabled	Input enabled	Input enabled	Input enabled	Input enabled
B	GPIO selected	Setting disabled	Setting disabled	Setting disabled	Maintain previous state	Maintain previous state	Hi-Z / Internal input fixed at "0"	Maintain previous state	Hi-Z / Internal input fixed at "0"	Maintain previous state
	Main crystal oscillator output pin	Hi-Z / Internal input fixed at "0" / or Input enable	Hi-Z / Internal input fixed at "0"	Hi-Z / Internal input fixed at "0"	Maintain previous state	Maintain previous state /When oscillation stop *1, Hi-Z / Internal input fixed at "0"	Maintain previous state /When oscillation stop *1, Hi-Z / Internal input fixed at "0"	Maintain previous state /When oscillation stop *1, Hi-Z / Internal input fixed at "0"	Maintain previous state /When oscillation stop *1, Hi-Z / Internal input fixed at "0"	Maintain previous state /When oscillation stop *1, Hi-Z / Internal input fixed at "0"
C	INITX input pin	Pull-up / Input enabled	Pull-up / Input enabled	Pull-up / Input enabled	Pull-up / Input enabled	Pull-up / Input enabled	Pull-up / Input enabled	Pull-up / Input enabled	Pull-up / Input enabled	Pull-up / Input enabled
D	Mode input pin	Input enabled	Input enabled	Input enabled	Input enabled	Input enabled	Input enabled	Input enabled	Input enabled	Input enabled

Pin status type	Function group	Power-on reset or low-voltage detection state	INITX input state	Device internal reset state	Run mode or sleep mode state	Timer mode, RTC mode, or sleep mode state		Deep stand-by RTC mode or Deep stand-by STOP mode state		Return from Deep stand-by mode state	
		Power supply unstable	Power supply stable		Power supply stable	Power supply stable		Power supply stable		Power supply stable	
		-	INITX = 0	INITX = 1	INITX = 1	INITX = 1		INITX = 1		INITX = 1	
		-	-	-	-	SPL = 0	SPL = 1	SPL = 0	SPL = 1	-	
E	JTAG selected	Hi-Z	Pull-up / Input enabled	Pull-up / Input enabled	Maintain previous state	Maintain previous state	Maintain previous state	Maintain previous state	Maintain previous state	Maintain previous state	
	GPIO selected	Setting disabled	Setting disabled	Setting disabled	Maintain previous state	Maintain previous state	Hi-Z / Internal input fixed at "0"	Maintain previous state	Hi-Z / Internal input fixed at "0"	Maintain previous state	
F	WKUP enabled	Setting disabled	Setting disabled	Setting disabled	Maintain previous state	Maintain previous state	Maintain previous state	WKUP input enabled	Hi-Z / WKUP input enabled	GPIO selected	
	Analog input selected	Hi-Z	Hi-Z / Internal input fixed at "0" / Analog input enabled	Hi-Z / Internal input fixed at "0" / Analog input enabled	Hi-Z / Internal input fixed at "0" / Analog input enabled	Hi-Z / Internal input fixed at "0" / Analog input enabled	Hi-Z / Internal input fixed at "0" / Analog input enabled	Hi-Z / Internal input fixed at "0" / Analog input enabled	Hi-Z / Internal input fixed at "0" / Analog input enabled	Hi-Z / Internal input fixed at "0" / Analog input enabled	
	External interrupt enabled selected	Setting disabled	Setting disabled	Setting disabled	Maintain previous state	Maintain previous state	Maintain previous state	GPIO selected	Hi-Z / Internal input fixed at "0"	GPIO selected	
	Resource other than above selected						Hi-Z / Internal input fixed at "0"				Maintain previous state
GPIO selected	Maintain previous state						Maintain previous state				
G	WKUP enabled	Setting disabled	Setting disabled	Setting disabled	Maintain previous state	Maintain previous state	Maintain previous state	WKUP input enabled	Hi-Z / WKUP input enabled	GPIO selected	
	External interrupt enabled selected	Setting disabled	Setting disabled	Setting disabled	Maintain previous state	Maintain previous state	Maintain previous state	GPIO selected	Hi-Z / Internal input fixed at "0"	GPIO selected	
	Resource other than above selected	Hi-Z	Hi-Z / Input enabled	Hi-Z / Input enabled			Hi-Z / Internal input fixed at "0"				Maintain previous state
	GPIO selected						Maintain previous state				Maintain previous state

Pin status type	Function group	Power-on reset or low-voltage detection state	INITX input state	Device internal reset state	Run mode or sleep mode state	Timer mode, RTC mode, or sleep mode state		Deep stand-by RTC mode or Deep stand-by STOP mode state		Return from Deep stand-by mode state		
		Power supply unstable	Power supply stable		Power supply stable	Power supply stable		Power supply stable		Power supply stable		
		-	INITX = 0	INITX = 1	INITX = 1	INITX = 1		INITX = 1		INITX = 1		
		-	-	-	-	SPL = 0	SPL = 1	SPL = 0	SPL = 1	-		
H	External interrupt enabled selected	Setting disabled	Setting disabled	Setting disabled	Maintain previous state	Maintain previous state	Maintain previous state	GPIO selected	Hi-Z / Internal input fixed at "0"	GPIO selected		
	Resource other than above selected	Hi-Z	Hi-Z / Input enabled	Hi-Z / Input enabled			Maintain previous state				Maintain previous state	Hi-Z / Internal input fixed at "0"
	GPIO selected											Maintain previous state
I	resource selected	Hi-Z	Hi-Z / Input enabled	Hi-Z / Input enabled	Maintain previous state	Maintain previous state	Hi-Z / Internal input fixed at "0"	GPIO selected	Hi-Z / Internal input fixed at "0"	GPIO selected		
	GPIO selected						Maintain previous state				Maintain previous state	
J	NMIX selected	Setting disabled	Setting disabled	Setting disabled	Maintain previous state	Maintain previous state	Maintain previous state	WKUP input enabled	Hi-Z / WKUP input enabled	GPIO selected		
	Resource other than above selected	Hi-Z	Hi-Z / Input enabled	Hi-Z / Input enabled			Maintain previous state				Maintain previous state	Hi-Z / Internal input fixed at "0"
	GPIO selected											Maintain previous state
K	Analog input selected	Hi-Z	Hi-Z / Internal input fixed at "0" / Analog input enabled	Hi-Z / Internal input fixed at "0" / Analog input enabled	Hi-Z / Internal input fixed at "0" / Analog input enabled	Hi-Z / Internal input fixed at "0" / Analog input enabled	Hi-Z / Internal input fixed at "0" / Analog input enabled	Hi-Z / Internal input fixed at "0" / Analog input enabled	Hi-Z / Internal input fixed at "0" / Analog input enabled	Hi-Z / Internal input fixed at "0" / Analog input enabled		
	Resource other than above selected		Setting disabled	Setting disabled	Setting disabled	Maintain previous state	Maintain previous state	Hi-Z / Internal input fixed at "0"	GPIO selected	Hi-Z / Internal input fixed at "0"	GPIO selected	
	GPIO selected	Maintain previous state						Maintain previous state				



Pin status type	Function group	Power-on reset or low-voltage detection state	INITX input state	Device internal reset state	Run mode or sleep mode state	Timer mode, RTC mode, or sleep mode state		Deep stand-by RTC mode or Deep stand-by STOP mode state		Return from Deep stand-by mode state
		Power supply unstable	Power supply stable		Power supply stable	Power supply stable		Power supply stable		Power supply stable
		-	INITX = 0	INITX = 1	INITX = 1	INITX = 1		INITX = 1		INITX = 1
		-	-	-	-	SPL = 0	SPL = 1	SPL = 0	SPL = 1	-
L	Analog input selected	Hi-Z	Hi-Z / Internal input fixed at "0" / Analog input enabled	Hi-Z / Internal input fixed at "0" / Analog input enabled	Hi-Z / Internal input fixed at "0" / Analog input enabled	Hi-Z / Internal input fixed at "0" / Analog input enabled	Hi-Z / Internal input fixed at "0" / Analog input enabled	Hi-Z / Internal input fixed at "0" / Analog input enabled	Hi-Z / Internal input fixed at "0" / Analog input enabled	Hi-Z / Internal input fixed at "0" / Analog input enabled
	External interrupt enabled selected	Setting disabled	Setting disabled	Setting disabled	Maintain previous state	Maintain previous state	Maintain previous state	GPIO selected	Hi-Z / Internal input fixed at "0"	GPIO selected
	Resource other than above selected						Hi-Z / Internal input fixed at "0"			
GPIO selected							Maintain previous state			Maintain previous state
M	GPIO selected	Setting disabled	Setting disabled	Setting disabled	Maintain previous state	Maintain previous state	Hi-Z / Internal input fixed at "0"	Maintain previous state	Hi-Z / Internal input fixed at "0"	Maintain previous state
	Sub crystal oscillator input pin	Input enabled	Input enabled	Input enabled	Input enabled	Input enabled	Input enabled	Input enabled	Input enabled	Input enabled
N	GPIO selected	Setting disabled	Setting disabled	Setting disabled	Maintain previous state	Maintain previous state	Hi-Z / Internal input fixed at "0"	Maintain previous state	Hi-Z / Internal input fixed at "0"	Maintain previous state
	Sub crystal oscillator output pin	Hi-Z / Internal input fixed at "0" / or Input enable	Hi-Z / Internal input fixed at "0"	Hi-Z / Internal input fixed at "0"	Maintain previous state	Maintain previous state /When oscillation stop <sup>2</sup> , Hi-Z / Internal input fixed at "0"	Maintain previous state /When oscillation stop <sup>2</sup> , Hi-Z / Internal input fixed at "0"	Maintain previous state /When oscillation stop <sup>2</sup> , Hi-Z / Internal input fixed at "0"	Maintain previous state /When oscillation stop <sup>2</sup> , Hi-Z / Internal input fixed at "0"	Maintain previous state /When oscillation stop <sup>2</sup> , Hi-Z / Internal input fixed at "0"

Pin status type	Function group	Power-on reset or low-voltage detection state	INITX input state	Device internal reset state	Run mode or sleep mode state	Timer mode, RTC mode, or sleep mode state		Deep stand-by RTC mode or Deep stand-by STOP mode state		Return from Deep stand-by mode state
		Power supply unstable	Power supply stable		Power supply stable	Power supply stable		Power supply stable		Power supply stable
		-	INITX = 0	INITX = 1	INITX = 1	INITX = 1		INITX = 1		INITX = 1
		-	-	-	-	SPL = 0	SPL = 1	SPL = 0	SPL = 1	-
O	GPIO selected	Hi-Z	Hi-Z / Input enabled	Hi-Z / Input enabled	Maintain previous state	Maintain previous state	Hi-Z / Internal input fixed at "0"	Maintain previous state	Hi-Z / Internal input fixed at "0"	Maintain previous state
	USB I/O pin	Setting disabled	Setting disabled	Setting disabled	Maintain previous state	Hi-Z at transmission / Input enabled / Internal input fixed at "0" at reception	Hi-Z at transmission / Input enabled / Internal input fixed at "0" at reception	Hi-Z / Input enabled	Hi-Z / Input enabled	Hi-Z / Input enabled
P	Mode input pin	Input enabled	Input enabled	Input enabled	Input enabled	Input enabled	Input enabled	Input enabled	Input enabled	Input enabled
	GPIO selected	Setting disabled	Setting disabled	Setting disabled	Maintain previous state	Maintain previous state	Hi-Z / Input enabled	Maintain previous state	Hi-Z / Input enabled	Maintain previous state

\*1: Oscillation is stopped at Sub timer mode, Low-speed CR timer mode, RTC mode, STOP mode, Deep stand-by RTC mode, and Deep stand-by STOP mode.

\*2: Oscillation is stopped at STOP mode and Deep stand-by STOP mode.

## 12. Electrical Characteristics

### 12.1 Absolute Maximum Ratings

Parameter	Symbol	Rating		Unit	Remarks
		Min	Max		
Power supply voltage <sup>*1, *2</sup>	V <sub>CC</sub>	V <sub>SS</sub> - 0.5	V <sub>SS</sub> + 6.5	V	
Power supply voltage (for USB) <sup>*1, *3</sup>	USBV <sub>CC</sub>	V <sub>SS</sub> - 0.5	V <sub>SS</sub> + 6.5	V	
Analog power supply voltage <sup>*1, *4</sup>	AV <sub>CC</sub>	V <sub>SS</sub> - 0.5	V <sub>SS</sub> + 6.5	V	
Analog reference voltage <sup>*1, *2</sup>	AV <sub>RH</sub>	V <sub>SS</sub> - 0.5	V <sub>SS</sub> + 6.5	V	
Input voltage	V <sub>I</sub>	V <sub>SS</sub> - 0.5	V <sub>CC</sub> + 0.5 (≤6.5 V)	V	Except for USB pin
		V <sub>SS</sub> - 0.5	USBV <sub>CC0</sub> + 0.5 (≤6.5 V)	V	USB pin
		V <sub>SS</sub> - 0.5	V <sub>SS</sub> + 6.5	V	5V tolerant
Analog pin input voltage	V <sub>IA</sub>	V <sub>SS</sub> - 0.5	AV <sub>CC</sub> + 0.5 (≤6.5 V)	V	
Output voltage	V <sub>O</sub>	V <sub>SS</sub> - 0.5	V <sub>CC</sub> + 0.5 (≤6.5 V)	V	
Clamp maximum current	I <sub>CLAMP</sub>	-2	+2	mA	*8
Clamp total maximum current	Σ[I <sub>CLAMP</sub> ]		+20	mA	*8
"L" level maximum output current <sup>*5</sup>	I <sub>OL</sub>	-	10	mA	4mA type
			20	mA	12mA type
			39	mA	P80, P81
"L" level average output current <sup>*6</sup>	I <sub>OLAV</sub>	-	4	mA	4mA type
			12	mA	12mA type
			18.5	mA	P80, P81
"L" level total maximum output current	ΣI <sub>OL</sub>	-	100	mA	
"L" level total average output current <sup>*7</sup>	ΣI <sub>OLAV</sub>	-	50	mA	
"H" level maximum output current <sup>*5</sup>	I <sub>OH</sub>	-	- 10	mA	4mA type
			- 20	mA	12mA type
			- 39	mA	P80, P81
"H" level average output current <sup>*6</sup>	I <sub>OHAV</sub>	-	- 4	mA	4mA type
			- 12	mA	12mA type
			- 20.5	mA	P80, P81
"H" level total maximum output current	ΣI <sub>OH</sub>	-	- 100	mA	
"H" level total average output current <sup>*7</sup>	ΣI <sub>OHAV</sub>	-	- 50	mA	
Power consumption	P <sub>D</sub>	-	300	mW	
Storage temperature	T <sub>STG</sub>	- 55	+ 150	°C	

\*1: These parameters are based on the condition that V<sub>SS</sub> = AV<sub>SS</sub> = 0.0 V.

\*2: V<sub>CC</sub> must not drop below V<sub>SS</sub> - 0.5 V.

\*3: USBV<sub>CC</sub> must not drop below V<sub>SS</sub> - 0.5 V.

\*4: Ensure that the voltage does not to exceed V<sub>CC</sub> + 0.5 V, for example, when the power is turned on.

\*5: The maximum output current is the peak value for a single pin.

\*6: The average output is the average current for a single pin over a period of 100 ms.

\*7: The total average output current is the average current for all pins over a period of 100 ms.

- \*8:
- See "List of Pin Functions" and "I/O Circuit Type" about +B input available pin.
  - Use within recommended operating conditions.
  - Use at DC voltage (current) the +B input.
  - The +B signal should always be applied a limiting resistance placed between the +B signal and the device.
  - The value of the limiting resistance should be set so that when the +B signal is applied the input current to the device pin does not exceed rated values, either instantaneously or for prolonged periods.
  - Note that when the device drive current is low, such as in the low-power consumption modes, the +B input potential may pass through the protective diode and increase the potential at the VCC and AVCC pin, and this may affect other devices.
  - Note that if a +B signal is input when the device power supply is off (not fixed at 0 V), the power supply is provided from the pins, so that incomplete operation may result.
  - The following is a recommended circuit example (I/O equivalent circuit).

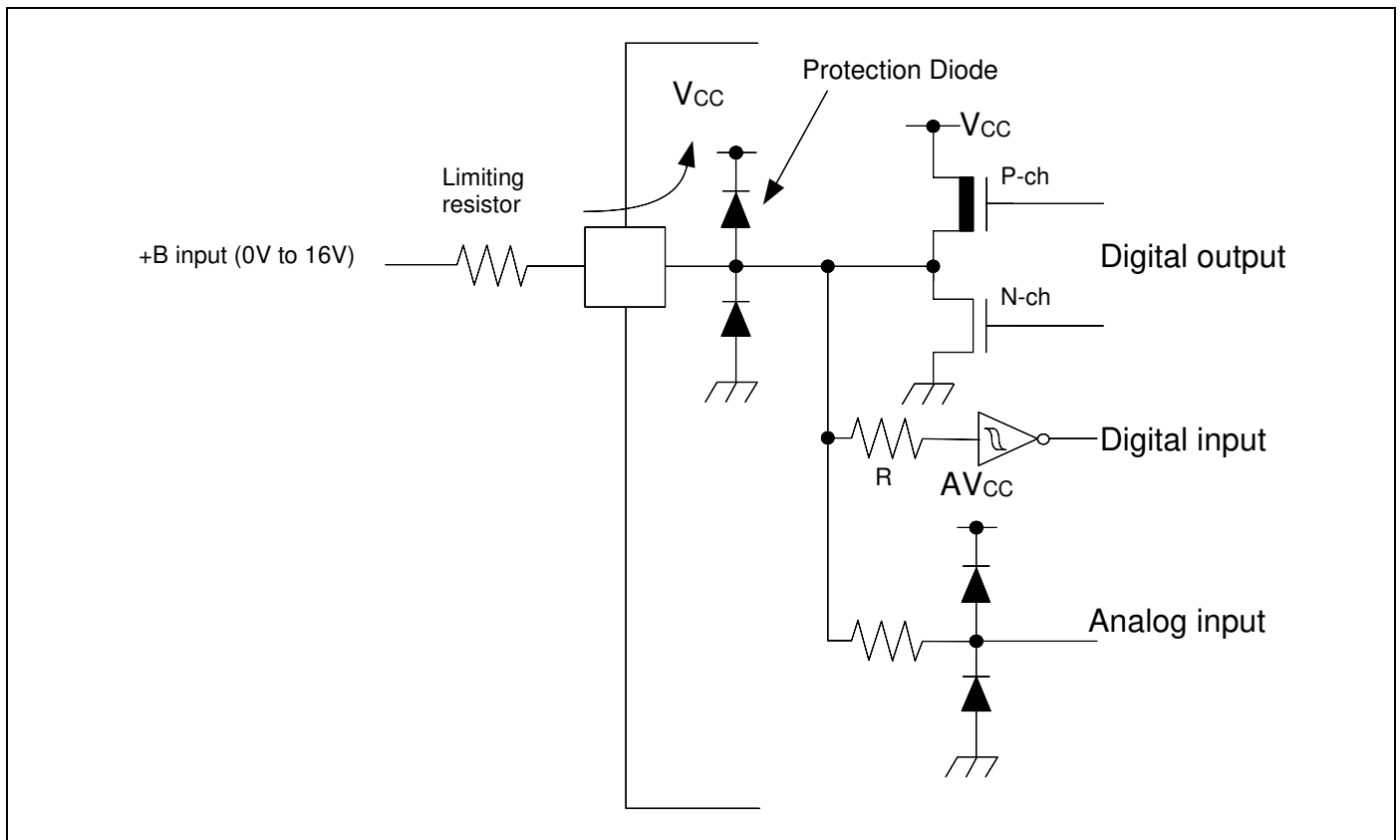

**WARNING:**

- Semiconductor devices can be permanently damaged by application of stress (voltage, current, temperature, etc.) in excess of absolute maximum ratings. Do not exceed these ratings.

**12.2 Recommended Operating Conditions**

 (V<sub>SS</sub> = AV<sub>SS</sub> = 0.0V)

Parameter	Symbol	Conditions	Value		Unit	Remarks
			Min	Max		
Power supply voltage	V <sub>CC</sub>	-	2.7 <sup>*4</sup>	5.5	V	
Power supply voltage for USB	USBV <sub>CC</sub>	-	3.0	3.6 (≤V <sub>CC</sub> )	V	*1
			2.7	5.5 (≤V <sub>CC</sub> )		*2
Analog power supply voltage	AV <sub>CC</sub>	-	2.7	5.5	V	AV <sub>CC</sub> = V <sub>CC</sub>
Analog reference voltage	AV <sub>RH</sub>	-	2.7	AV <sub>CC</sub>	V	
Smoothing capacitor	C <sub>S</sub>	-	1	10	μF	For built-in regulator <sup>*3</sup>
Operating temperature	T <sub>A</sub>	-	- 40	+ 105	°C	

\*1: When P81/UDP0 and P80/UDM0 pin are used as USB (UDP0, UDM0).

\*2: When P81/UDP0 and P80/UDM0 pin are used as GPIO (P81, P80).

\*3: See "C Pin" in "Handling Devices" for the connection of the smoothing capacitor.

\*4: In between less than the minimum power supply voltage and low voltage reset/interrupt detection voltage or more, instruction execution and low voltage detection function by built-in High-speed CR (including Main PLL is used) or built-in Low-speed CR is possible to operate only.

**WARNING:**

- *The recommended operating conditions are required in order to ensure the normal operation of the semiconductor device. All of the device's electrical characteristics are warranted when the device is operated within these ranges. Always use semiconductor devices within their recommended operating condition ranges. Operation outside these ranges may adversely affect reliability and could result in device failure. No warranty is made with respect to uses, operating conditions, or combinations not represented on the Datasheet. Users considering application outside the listed conditions are advised to contact their representatives beforehand.*

## 12.3 DC Characteristics

### 12.3.1 Current Rating

(V<sub>CC</sub> = AV<sub>CC</sub> = 2.7V to 5.5V, USBV<sub>CC</sub> = 3.0V to 3.6V, V<sub>SS</sub> = AV<sub>SS</sub> = 0V, T<sub>A</sub> = - 40°C to + 105°C)

Parameter	Symbol	Pin Name	Conditions	Value		Unit	Remarks
				Typ <sup>*3</sup>	Max <sup>*4</sup>		
RUN mode current	I <sub>CC</sub>	V <sub>CC</sub>	PLL RUN mode CPU: 40 MHz, Peripheral: 40 MHz, MainFlash 0 Wait FRWTR.RWT = 00 FSYNDN.SD = 000	32	41	mA	*1, *5
			High-speed CR RUN mode CPU: 40 MHz, Peripheral: 40 MHz, MainFlash 3 Wait FRWTR.RWT = 00 FSYNDN.SD = 011	21	28	mA	*1, *5
			High-speed CR RUN mode CPU/ Peripheral: 4 MHz <sup>*2</sup> MainFlash 0 Wait FRWTR.RWT = 00 FSYNDN.SD = 000	3.9	7.7	mA	*1
			Sub RUN mode CPU/ Peripheral: 32 kHz MainFlash 0 Wait FRWTR.RWT = 00 FSYNDN.SD = 000	0.15	3.2	mA	*1, *6
			Low-speed CR RUN mode CPU/ Peripheral: 100 kHz MainFlash 0 Wait FRWTR.RWT = 00 FSYNDN.SD = 000	0.2	3.3	mA	*1
SLEEP mode current	I <sub>CCS</sub>	V <sub>CC</sub>	PLL SLEEP mode Peripheral: 40 MHz	10	15	mA	*1, *5
			High-speed CR SLEEP mode Peripheral: 4 MHz <sup>*2</sup>	1.2	4.4	mA	*1
			Sub SLEEP mode Peripheral: 32 kHz	0.1	3.1	mA	*1, *6
			Low-speed CR SLEEP mode Peripheral: 100 kHz	0.1	3.1	mA	*1

\*1: When all ports are input and are fixed at "0".

\*2: When setting it to 4 MHz by trimming.

\*3: T<sub>A</sub> = +25°C, V<sub>CC</sub> = 5.5V

\*4: T<sub>A</sub> = +105°C, V<sub>CC</sub> = 5.5V

\*5: When using the crystal oscillator of 4 MHz (Including the current consumption of the oscillation circuit)

\*6: When using the crystal oscillator of 32 kHz (Including the current consumption of the oscillation circuit)

(V<sub>CC</sub> = AV<sub>CC</sub> = 2.7V to 5.5V, USBV<sub>CC</sub> = 3.0V to 3.6V, V<sub>SS</sub> = AV<sub>SS</sub> = 0V, T<sub>A</sub> = - 40°C to + 105°C)

Parameter	Symbol	Pin Name	Conditions	Value		Unit	Remarks	
				Typ*2	Max*2			
TIMER mode current	I <sub>CC1</sub>	VCC	Main TIMER mode	T <sub>A</sub> = + 25°C, When LVD is off	5.2	6	mA	*1, *3
				T <sub>A</sub> = + 105°C, When LVD is off	-	9	mA	*1, *3
			Sub TIMER mode	T <sub>A</sub> = + 25°C, When LVD is off	60	230	μA	*1, *4
				T <sub>A</sub> = + 105°C, When LVD is off	-	3.1	mA	*1, *4
RTC mode current	I <sub>CCR</sub>		RTC mode	T <sub>A</sub> = + 25°C, When LVD is off	50	210	μA	*1, *4
				T <sub>A</sub> = + 105°C, When LVD is off	-	3.1	mA	*1, *4
STOP mode current	I <sub>CCH</sub>		STOP mode	T <sub>A</sub> = + 25°C, When LVD is off	35	200	μA	*1
				T <sub>A</sub> = + 105°C, When LVD is off	-	3	mA	*1
Deep stand-by mode current	I <sub>CCRD</sub>	Deep stand-by RTC mode	T <sub>A</sub> = + 25°C, When LVD is off RAM hold off	30	160	μA	*1, *4	
			T <sub>A</sub> = + 25°C, When LVD is off RAM hold on	33	160	mA	*1, *4	
			T <sub>A</sub> = + 105°C, When LVD is off RAM hold off	-	600	μA	*1	
			T <sub>A</sub> = + 105°C, When LVD is off RAM hold on	-	610	mA	*1	
	I <sub>CCHD</sub>	Deep stand-by STOP mode	T <sub>A</sub> = + 25°C, When LVD is off RAM hold off	20	150	μA	*1, *4	
			T <sub>A</sub> = + 25°C, When LVD is off RAM hold on	23	150	mA	*1, *4	
			T <sub>A</sub> = + 105°C, When LVD is off RAM hold off	-	600	μA	*1	
			T <sub>A</sub> = + 105°C, When LVD is off RAM hold on	-	610	mA	*1	

\*1: When all ports are input and are fixed at "0".

 \*2: V<sub>CC</sub> = 5.5 V

\*3: When using the crystal oscillator of 4 MHz (Including the current consumption of the oscillation circuit)

\*4: When using the crystal oscillator of 32 kHz (Including the current consumption of the oscillation circuit)

**Low-Voltage Detection Current**
 $(V_{CC} = 2.7V \text{ to } 5.5V, V_{SS} = 0V, T_A = -40^{\circ}C \text{ to } +105^{\circ}C)$ 

Parameter	Symbol	Pin name	Conditions	Value		Unit	Remarks
				Typ	Max		
Low-voltage detection circuit (LVD) power supply current	I <sub>CC</sub> LVD	VCC	At operation for interrupt V <sub>CC</sub> = 5.5 V	4	7	μA	At not detect

**Flash Memory Current**
 $(V_{CC} = 2.7V \text{ to } 5.5V, V_{SS} = 0V, T_A = -40^{\circ}C \text{ to } +105^{\circ}C)$ 

Parameter	Symbol	Pin name	Conditions	Value		Unit	Remarks
				Typ	Max		
Flash memory write/erase current	I <sub>CC</sub> FLASH	VCC	MainFlash At Write/Erase	11.4	13.1	mA	
			WorkFlash At Write/Erase	11.4	13.1	mA	

**A/D Converter Current**
 $(V_{CC} = AV_{CC} = 2.7V \text{ to } 5.5V, V_{SS} = AV_{SS} = AV_{RL} = 0V, T_A = -40^{\circ}C \text{ to } +105^{\circ}C)$ 

Parameter	Symbol	Pin name	Conditions	Value		Unit	Remarks
				Typ	Max		
Power supply current	I <sub>CC</sub> AD	AVCC	At 1unit operation	0.57	0.72	mA	
			At stop	0.06	20	μA	
Reference power supply current	I <sub>CC</sub> AVRH	AVRH	At 1unit operation AVRH = 5.5 V	1.1	1.96	mA	
			At stop	0.06	4	μA	



**12.3.2 Pin Characteristics**
 $(V_{CC} = AV_{CC} = 2.7V \text{ to } 5.5V, V_{SS} = AV_{SS} = 0V, T_A = -40^{\circ}C \text{ to } +105^{\circ}C)$ 

Parameter	Symbol	Pin name	Conditions	Value			Unit	Remarks
				Min	Typ	Max		
"H" level input voltage (hysteresis input)	$V_{IHS}$	CMOS hysteresis input pin, MD0, MD1	-	$V_{CC} \times 0.8$	-	$V_{CC} + 0.3$	V	
		5V tolerant input pin	-	$V_{CC} \times 0.8$	-	$V_{SS} + 5.5$	V	
"L" level input voltage (hysteresis input)	$V_{ILS}$	CMOS hysteresis input pin, MD0, MD1	-	$V_{SS} - 0.3$	-	$V_{CC} \times 0.2$	V	
		5V tolerant input pin	-	$V_{SS} - 0.3$	-	$V_{CC} \times 0.2$	V	
"H" level output voltage	$V_{OH}$	4mA type	$V_{CC} \geq 4.5 V$ $I_{OH} = -4 \text{ mA}$	$V_{CC} - 0.5$	-	$V_{CC}$	V	
			$V_{CC} < 4.5 V$ $I_{OH} = -2 \text{ mA}$					
		12mA type	$V_{CC} \geq 4.5 V$ $I_{OH} = -12 \text{ mA}$	$V_{CC} - 0.5$	-	$V_{CC}$	V	
			$V_{CC} < 4.5 V$ $I_{OH} = -8 \text{ mA}$					
		P80/P81	$USBV_{CC} \geq 4.5 V$ $I_{OH} = -20.5 \text{ mA}$	$USBV_{CC} - 0.4$	-	$USBV_{CC}$	V	
			$USBV_{CC} < 4.5 V$ $I_{OH} = -13.0 \text{ mA}$					
"L" level output voltage	$V_{OL}$	4mA type	$V_{CC} \geq 4.5 V$ $I_{OL} = 4 \text{ mA}$	$V_{SS}$	-	0.4	V	
			$V_{CC} < 4.5 V$ $I_{OL} = 2 \text{ mA}$					
		12mA type	$V_{CC} \geq 4.5 V$ $I_{OL} = 12 \text{ mA}$	$V_{SS}$	-	0.4	V	
			$V_{CC} < 4.5 V$ $I_{OL} = 8 \text{ mA}$					
		P80/P81	$USBV_{CC} \geq 4.5 V$ $I_{OL} = 18.5 \text{ mA}$	$V_{SS}$	-	0.4	V	
			$USBV_{CC} < 4.5 V$ $I_{OL} = 10.5 \text{ mA}$					
Input leak current	$I_{IL}$	-	-	-5	-	+5	$\mu A$	
Pull-up resistance Value	$R_{PU}$	Pull-up pin	$V_{CC} \geq 4.5 V$	25	50	100	k $\Omega$	
			$V_{CC} < 4.5 V$	30	80	200		
Input capacitance	$C_{IN}$	Other than VCC, USBVCC, VSS, AVCC, AVSS, AVRH	-	-	5	15	pF	

## 12.4 AC Characteristics

### 12.4.1 Main Clock Input Characteristics

(V<sub>CC</sub> = 2.7V to 5.5V, V<sub>SS</sub> = 0V, T<sub>A</sub> = - 40°C to + 105°C)

Parameter	Symbol	Pin name	Conditions	Value		Unit	Remarks	
				Min	Max			
Input frequency	F <sub>CH</sub>	X0 X1	V <sub>CC</sub> ≥ 4.5 V	4	48	MHz	When crystal oscillator is connected	
			V <sub>CC</sub> < 4.5 V	4	20			
			V <sub>CC</sub> ≥ 4.5 V	4	48	MHz	When using external Clock	
			V <sub>CC</sub> < 4.5 V	4	20			
Input clock cycle	t <sub>CY LH</sub>		V <sub>CC</sub> ≥ 4.5 V	20.83	250	ns	When using external Clock	
			V <sub>CC</sub> < 4.5 V	50	250			
Input clock pulse width	-			P <sub>WH</sub> /t <sub>CY LH</sub> P <sub>WL</sub> /t <sub>CY LH</sub>	45	55	%	When using external Clock
Input clock rise time and fall time	t <sub>CF</sub> t <sub>CR</sub>			-	-	5	ns	When using external Clock
Internal operating clock frequency* <sup>1</sup>	F <sub>CM</sub>	-	-	-	42	MHz	Master clock	
	F <sub>CC</sub>	-	-	-	42	MHz	Base clock (HCLK/FCLK)	
	F <sub>CP0</sub>	-	-	-	42	MHz	APB0 bus clock* <sup>2</sup>	
	F <sub>CP1</sub>	-	-	-	42	MHz	APB1 bus clock* <sup>2</sup>	
	F <sub>CP2</sub>	-	-	-	42	MHz	APB2 bus clock* <sup>2</sup>	
Internal operating clock cycle time* <sup>1</sup>	t <sub>CYCC</sub>	-	-	23.8	-	ns	Base clock (HCLK/FCLK)	
	t <sub>CYCP0</sub>	-	-	23.8	-	ns	APB0 bus clock* <sup>2</sup>	
	t <sub>CYCP1</sub>	-	-	23.8	-	ns	APB1 bus clock* <sup>2</sup>	
	t <sub>CYCP2</sub>	-	-	23.8	-	ns	APB2 bus clock* <sup>2</sup>	

\*1: For more information about each internal operating clock, see "Chapter 2-1: Clock" in "FM3 Family Peripheral Manual".

\*2: For about each APB bus which each peripheral is connected to, see "Block Diagram" in this datasheet.

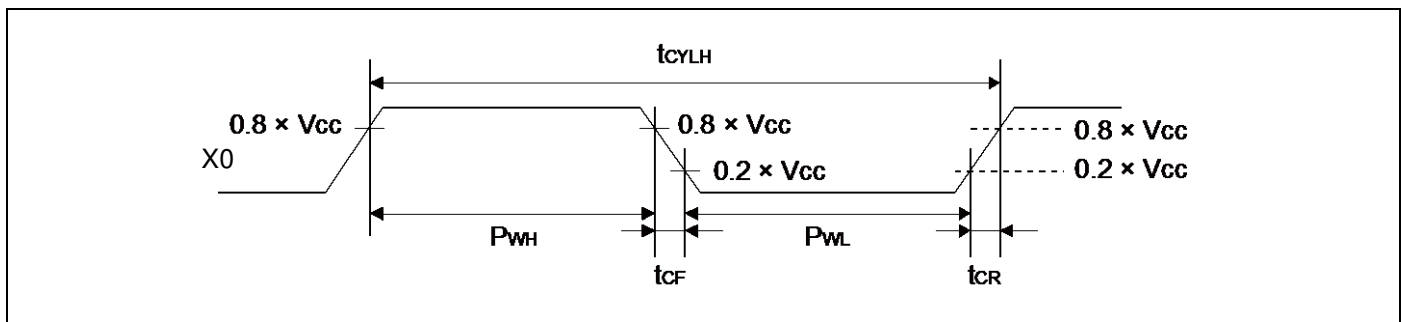

**12.4.2 Sub Clock Input Characteristics**

 (V<sub>CC</sub> = 2.7V to 5.5V, V<sub>SS</sub> = 0V, T<sub>A</sub> = - 40°C to + 105°C)

Parameter	Symbol	Pin name	Conditions	Value			Unit	Remarks
				Min	Typ	Max		
Input frequency	1/ t <sub>CYLL</sub>	X0A X1A	-	-	32.768	-	kHz	When crystal oscillator is connected
Input clock cycle	t <sub>CYLL</sub>		-	32	-	100	kHz	When using external clock
Input clock pulse width	-		P <sub>WH</sub> /t <sub>CYLL</sub>	45	-	55	%	When using external clock
			P <sub>WL</sub> /t <sub>CYLL</sub>					

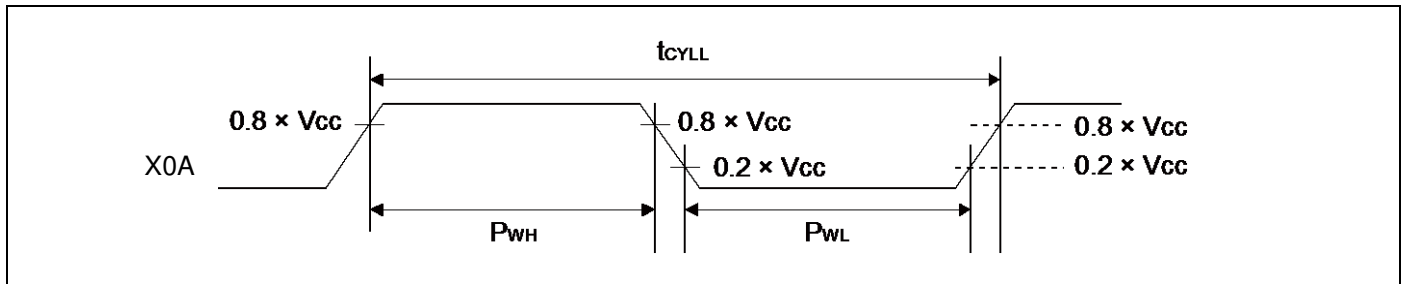
**12.4.3 Internal CR Oscillation Characteristics**
**High-speed Internal CR**

 (V<sub>CC</sub> = 2.7V to 5.5V, V<sub>SS</sub> = 0V, T<sub>A</sub> = - 40°C to + 105°C)

Parameter	Symbol	Conditions	Value			Unit	Remarks
			Min	Typ	Max		
Clock frequency	F <sub>CRH</sub>	T <sub>A</sub> = + 25°C	3.96	4	4.04	MHz	When trimming <sup>*1</sup>
		T <sub>A</sub> = 0°C to + 70°C	3.84	4	4.16		
		T <sub>A</sub> = - 40°C to + 85°C	3.8	4	4.2		
		T <sub>A</sub> = - 40°C to + 85°C	3	4	5		When not trimming
Frequency stability time	t <sub>CRWT</sub>	-	-	-	90	μs	*2

\*1: In the case of using the values in CR trimming area of Flash memory at shipment for frequency trimming.

\*2: Frequency stable time is time to stable of the frequency of the High-speed CR clock after the trim value is set. After setting the trim value, the period when the frequency stability time passes can use the High-speed CR clock as a source clock.

**Low-speed Internal CR**

 (V<sub>CC</sub> = 2.7V to 5.5V, V<sub>SS</sub> = 0V, T<sub>A</sub> = - 40°C to + 105°C)

Parameter	Symbol	Conditions	Value			Unit	Remarks
			Min	Typ	Max		
Clock frequency	F <sub>CRL</sub>	-	50	100	150	kHz	

### 12.4.4 Operating Conditions of Main and USB PLL (In the case of using main clock for input of PLL)

(V<sub>CC</sub> = 2.7V to 5.5V, V<sub>SS</sub> = 0V, T<sub>A</sub> = - 40°C to + 105°C)

Parameter	Symbol	Value			Unit	Remarks
		Min	Typ	Max		
PLL oscillation stabilization wait time <sup>*1</sup> (LOCK UP time)	t <sub>LOCK</sub>	100	-	-	μs	
PLL input clock frequency	F <sub>PLLI</sub>	4	-	16	MHz	
PLL multiple rate	-	13	-	75	multiple	
PLL macro oscillation clock frequency	F <sub>PLLO</sub>	200	-	300	MHz	
Main PLL clock frequency <sup>*2</sup>	F <sub>CLKPLL</sub>	-	-	40	MHz	
USB clock frequency <sup>*3</sup>	F <sub>CLKSPLL</sub>	-	-	48	MHz	After the M frequency division

\*1: Time from when the PLL starts operating until the oscillation stabilizes.

\*2: For more information about Main PLL clock (CLKPLL), see "Chapter 2-1: Clock" in "FM3 Family Peripheral Manual".

\*3: For more information about USB clock, see "Chapter 2-2: USB Clock Generation" in "FM3 Family Peripheral Manual Communication Macro Part".

### 12.4.5 Operating Conditions of Main PLL (In the case of using high-speed internal CR)

(V<sub>CC</sub> = 2.7V to 5.5V, V<sub>SS</sub> = 0V, T<sub>A</sub> = - 40°C to + 105°C)

Parameter	Symbol	Value			Unit	Remarks
		Min	Typ	Max		
PLL oscillation stabilization wait time <sup>*1</sup> (LOCK UP time)	t <sub>LOCK</sub>	100	-	-	μs	
PLL input clock frequency	F <sub>PLLI</sub>	3.8	4	4.2	MHz	
PLL multiple rate	-	50	-	71	multiple	
PLL macro oscillation clock frequency	F <sub>PLLO</sub>	190	-	300	MHz	
Main PLL clock frequency <sup>*2</sup>	F <sub>CLKPLL</sub>	-	-	42	MHz	

\*1: Time from when the PLL starts operating until the oscillation stabilizes.

\*2: For more information about Main PLL clock (CLKPLL), see "Chapter 2-1: Clock" in "FM3 Family Peripheral Manual".

When setting PLL multiple rate, please take the accuracy of the built-in high-speed CR clock into account and prevent the master clock from exceeding the maximum frequency.

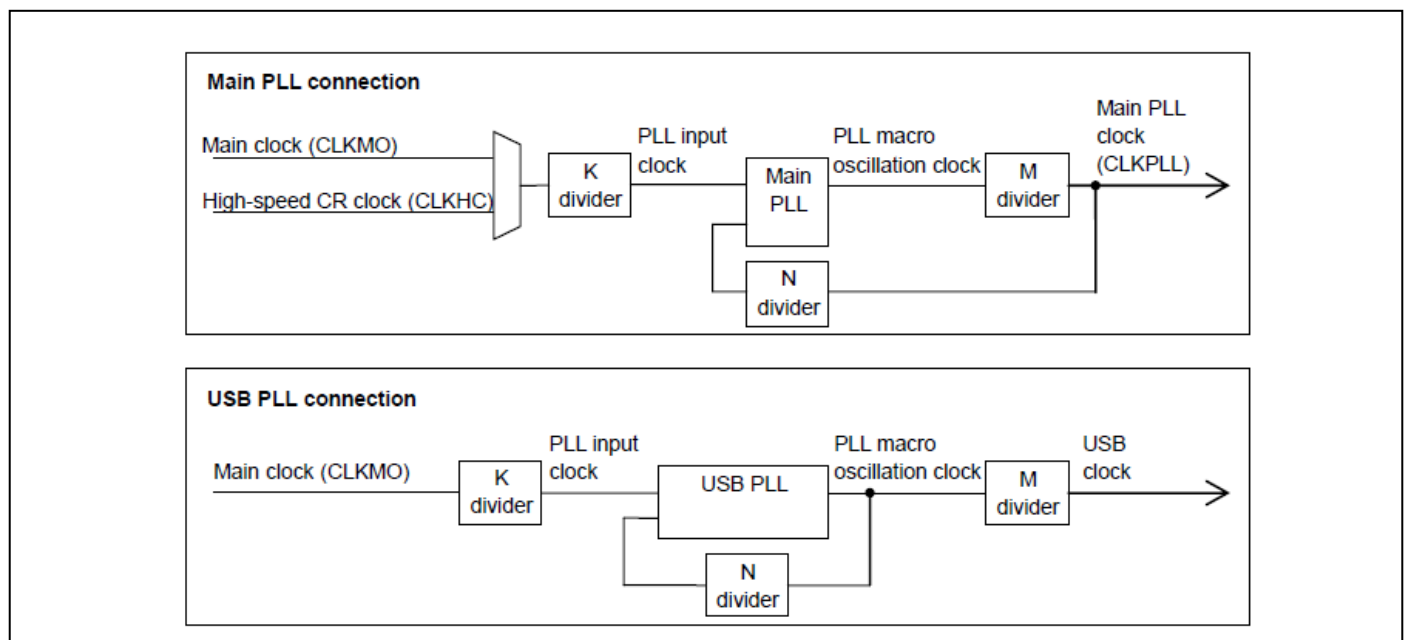

## 12.4.6 Reset Input Characteristics

(V<sub>CC</sub> = 2.7V to 5.5V, V<sub>SS</sub> = 0V, T<sub>A</sub> = - 40°C to + 105°C)

Parameter	Symbol	Pin name	Conditions	Value		Unit	Remarks
				Min	Max		
Reset input time	t <sub>INITX</sub>	INITX	-	500	-	ns	

## 12.4.7 Power-on Reset Timing

(V<sub>SS</sub> = 0V, T<sub>A</sub> = - 40°C to + 85°C)

Parameter	Symbol	Pin Name	Conditions	Value			Unit	Remarks
				Min	Typ	Max		
Power supply shut down time	t <sub>OFF</sub>	V <sub>CC</sub>	-	50	-	-	ms	*1
Power ramp rate	dV/dt		V <sub>CC</sub> : 0.2 V to 2.70 V	0.7	-	1000	mV/μs	*2
Time until releasing Power-on reset	t <sub>PRT</sub>		-	0.66	-	0.89	ms	

\*1: V<sub>CC</sub> must be held below 0.2 V for a minimum period of t<sub>OFF</sub>. Improper initialization may occur if this condition is not met.

\*2: This dV/dt characteristic is applied at the power-on of cold start (t<sub>OFF</sub>>50 ms).

### Note:

- t<sub>OFF</sub> must be satisfied. When t<sub>OFF</sub> cannot be satisfied, assert external reset (INITX) at power-up and at any brownout event.

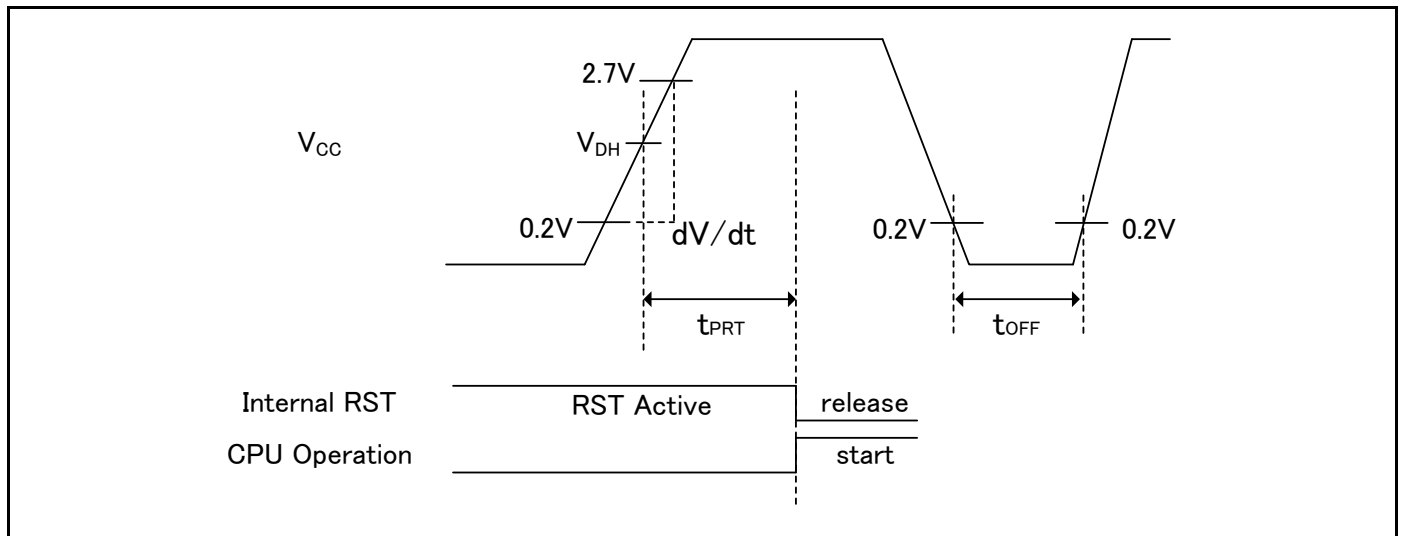

### Glossary

- V<sub>DH</sub>: detection voltage of Low-Voltage detection reset. See 12.7 Low-voltage Detection Characteristics.

### 12.4.8 Base Timer Input Timing

#### Timer input timing

( $V_{CC} = 2.7V$  to  $5.5V$ ,  $V_{SS} = 0V$ ,  $T_A = -40^{\circ}C$  to  $+105^{\circ}C$ )

Parameter	Symbol	Pin name	Conditions	Value		Unit	Remarks
				Min	Max		
Input pulse width	$t_{TIWH}$ $t_{TIWL}$	TIOAn/TIOBn (when using as ECK, TIN)	-	$2t_{CYCP}$	-	ns	

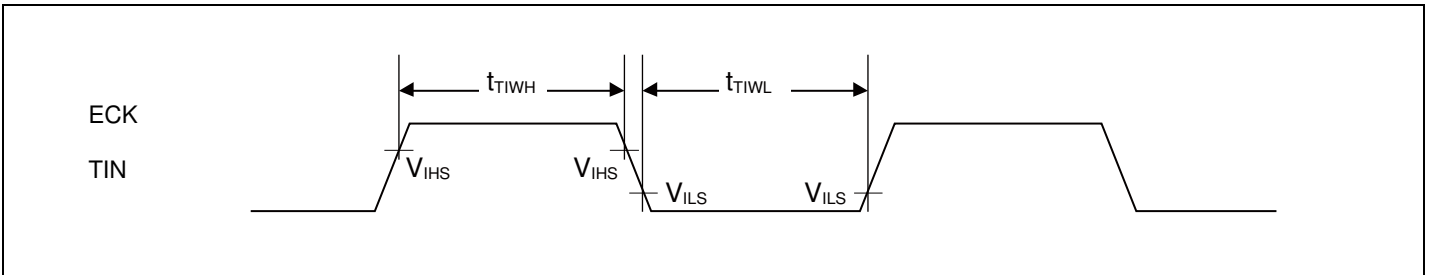

#### Trigger input timing

( $V_{CC} = 2.7V$  to  $5.5V$ ,  $V_{SS} = 0V$ ,  $T_A = -40^{\circ}C$  to  $+105^{\circ}C$ )

Parameter	Symbol	Pin name	Conditions	Value		Unit	Remarks
				Min	Max		
Input pulse width	$t_{TRGH}$ $t_{TRGL}$	TIOAn/TIOBn (when using as TGIN)	-	$2t_{CYCP}$	-	ns	

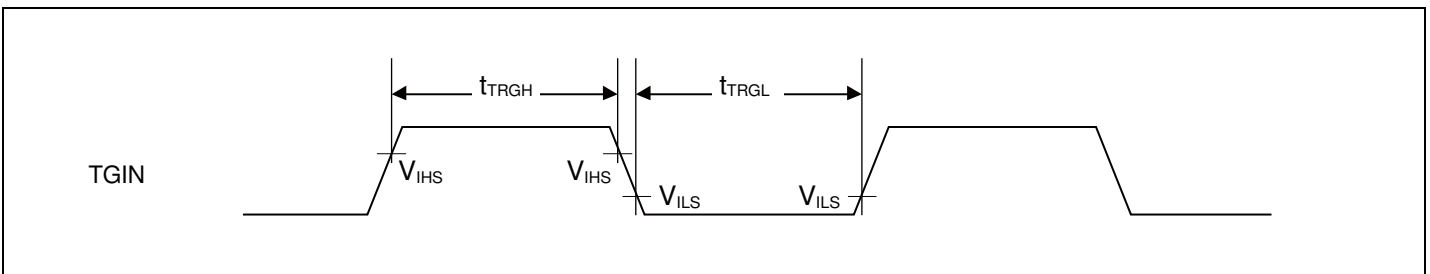

#### Note:

- $t_{CYCP}$  indicates the APB bus clock cycle time.  
About the APB bus number which UART is connected to, see "Block Diagram" in this datasheet.

**12.4.9 CSIO/UART Timing**
**CSIO (SPI = 0, SCINV = 0)**

 (V<sub>CC</sub> = 2.7V to 5.5V, V<sub>SS</sub> = 0V, T<sub>A</sub> = - 40°C to + 105°C)

Parameter	Symbol	Pin name	Conditions	V <sub>CC</sub> < 4.5 V		V <sub>CC</sub> ≥ 4.5 V		Unit
				Min	Max	Min	Max	
Baud rate	-	-	-	-	8	-	8	Mbps
Serial clock cycle time	t <sub>SCYC</sub>	SCKx	Master mode	4t <sub>CYCP</sub>	-	4t <sub>CYCP</sub>	-	ns
SCK ↓ → SOT delay time	t <sub>SLOVI</sub>	SCKx SOTx		-30	+30	- 20	+ 20	ns
SIN → SCK ↑ setup time	t <sub>IVSHI</sub>	SCKx SINx		50	-	30	-	ns
SCK ↑ → SIN hold time	t <sub>SHIXI</sub>	SCKx SINx		0	-	0	-	ns
Serial clock "L" pulse width	t <sub>SLSH</sub>	SCKx	Slave mode	2t <sub>CYCP</sub> - 10	-	2t <sub>CYCP</sub> - 10	-	ns
Serial clock "H" pulse width	t <sub>SHSL</sub>	SCKx		t <sub>CYCP</sub> + 10	-	t <sub>CYCP</sub> + 10	-	ns
SCK ↓ → SOT delay time	t <sub>SLOVE</sub>	SCKx SOTx		-	50	-	30	ns
SIN → SCK ↑ setup time	t <sub>IVSHE</sub>	SCKx SINx		10	-	10	-	ns
SCK ↑ → SIN hold time	t <sub>SHIXE</sub>	SCKx SINx		20	-	20	-	ns
SCK fall time	t <sub>F</sub>	SCKx		-	5	-	5	ns
SCK rise time	t <sub>R</sub>	SCKx		-	5	-	5	ns

**Notes:**

- The above characteristics apply to CLK synchronous mode.
- t<sub>CYCP</sub> indicates the APB bus clock cycle time.  
About the APB bus number which Multi-function Serial is connected to, see "Block Diagram" in this Datasheet.
- These characteristics only guarantee the same relocate port number.  
For example, the combination of SCKx\_0 and SOTx\_1 is not guaranteed.
- When the external load capacitance = 30 pF.

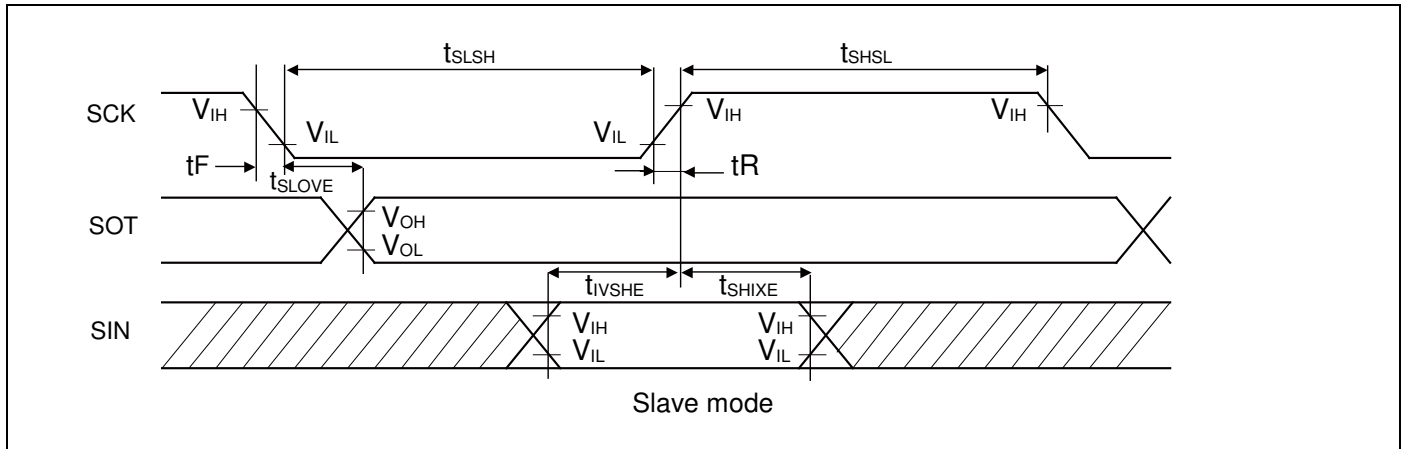
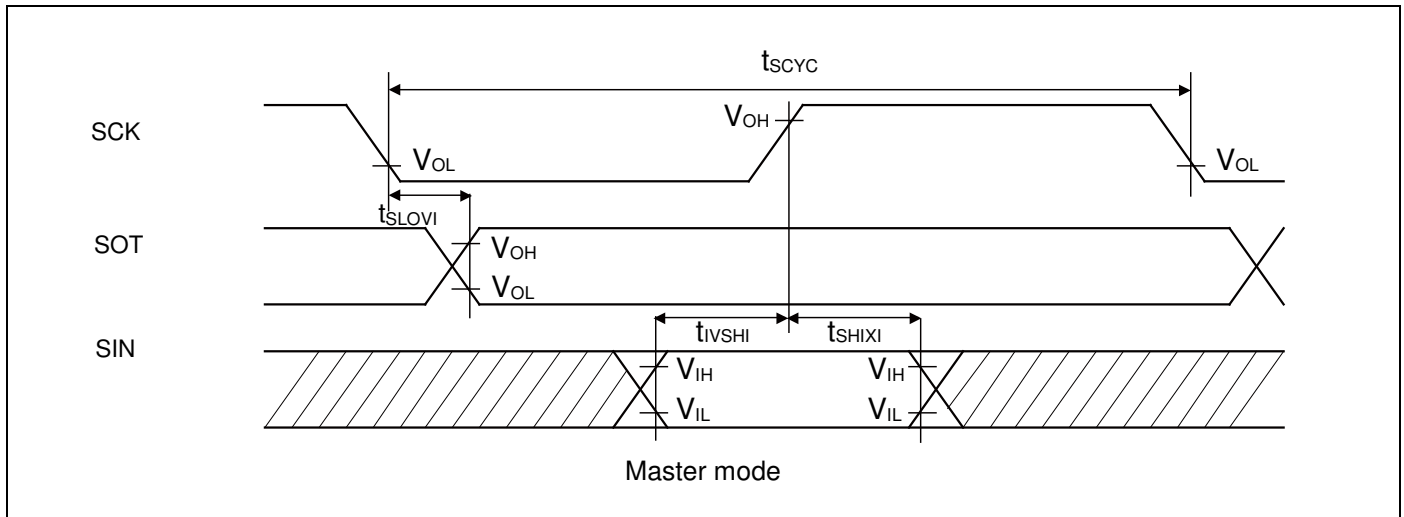



**CSIO (SPI = 0, SCINV = 1)**

 (V<sub>CC</sub> = 2.7V to 5.5V, V<sub>SS</sub> = 0V, T<sub>A</sub> = - 40°C to + 105°C)

Parameter	Symbol	Pin name	Conditions	V <sub>CC</sub> < 4.5 V		V <sub>CC</sub> ≥ 4.5 V		Unit
				Min	Max	Min	Max	
Baud rate	-	-	-	-	8	-	8	Mbps
Serial clock cycle time	t <sub>SCYC</sub>	SCKx	Master mode	4t <sub>CYCP</sub>	-	4t <sub>CYCP</sub>	-	ns
SCK ↑ → SOT delay time	t <sub>SHOVI</sub>	SCKx SOTx		-30	+30	- 20	+ 20	ns
SIN → SCK ↓ setup time	t <sub>IVSLI</sub>	SCKx SINx		50	-	30	-	ns
SCK ↓ → SIN hold time	t <sub>SLIXI</sub>	SCKx SINx		0	-	0	-	ns
Serial clock "L" pulse width	t <sub>LSLH</sub>	SCKx		2t <sub>CYCP</sub> - 10	-	2t <sub>CYCP</sub> - 10	-	ns
Serial clock "H" pulse width	t <sub>SHSL</sub>	SCKx	t <sub>CYCP</sub> + 10	-	t <sub>CYCP</sub> + 10	-	ns	
SCK ↑ → SOT delay time	t <sub>SHOVE</sub>	SCKx SOTx	Slave mode	-	50	-	30	ns
SIN → SCK ↓ setup time	t <sub>IVSLE</sub>	SCKx SINx		10	-	10	-	ns
SCK ↓ → SIN hold time	t <sub>SLIXE</sub>	SCKx SINx		20	-	20	-	ns
SCK fall time	t <sub>F</sub>	SCKx		-	5	-	5	ns
SCK rise time	t <sub>R</sub>	SCKx		-	5	-	5	ns

**Notes:**

- The above characteristics apply to CLK synchronous mode.
- t<sub>CYCP</sub> indicates the APB bus clock cycle time.  
About the APB bus number which Multi-function Serial is connected to, see "Block Diagram" in this Datasheet.
- These characteristics only guarantee the same relocate port number.  
For example, the combination of SCKx\_0 and SOTx\_1 is not guaranteed.
- When the external load capacitance = 30 pF.

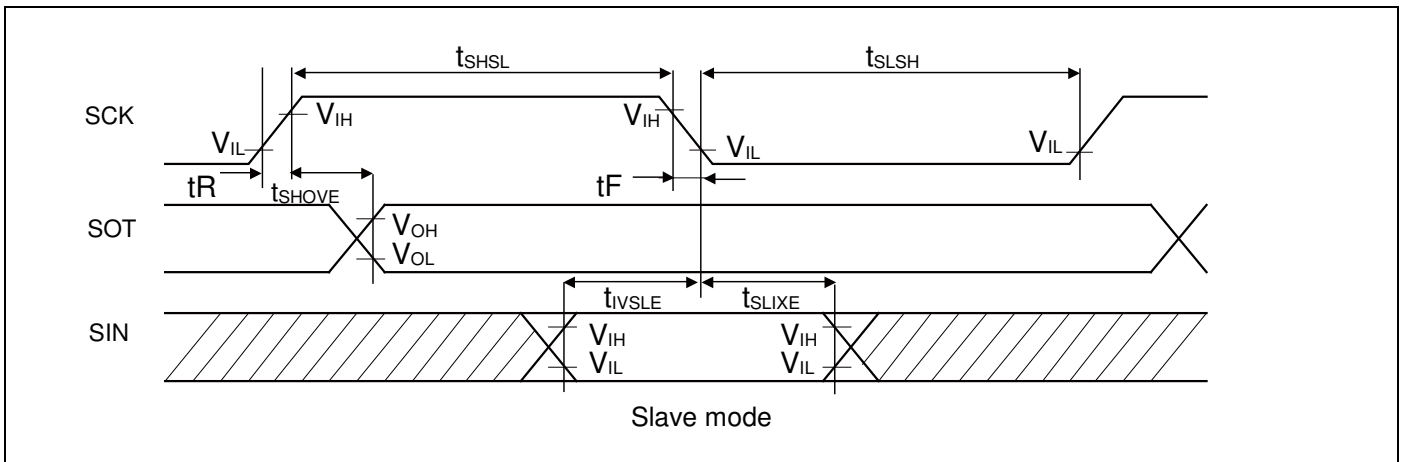
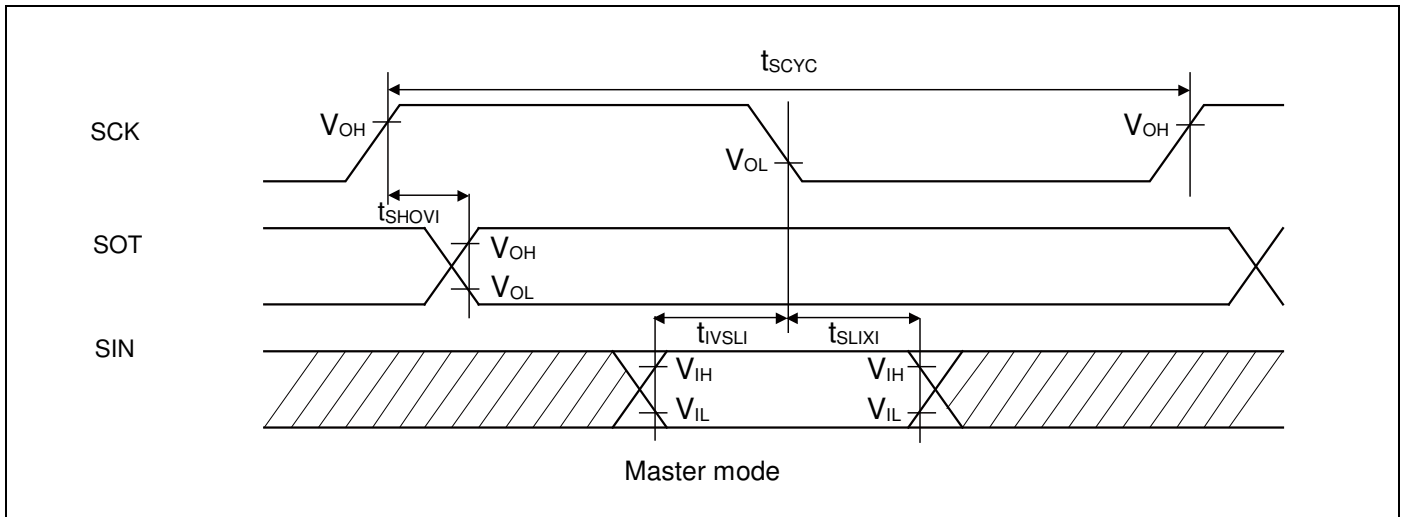

**CSIO (SPI = 1, SCINV = 0)**

 (V<sub>CC</sub> = 2.7V to 5.5V, V<sub>SS</sub> = 0V, T<sub>A</sub> = - 40°C to + 105°C)

Parameter	Symbol	Pin name	Conditions	V <sub>CC</sub> < 4.5 V		V <sub>CC</sub> ≥ 4.5 V		Unit
				Min	Max	Min	Max	
Baud rate	-	-	-	-	8	-	8	Mbps
Serial clock cycle time	t <sub>SCYC</sub>	SCKx	Master mode	4t <sub>CYCP</sub>	-	4t <sub>CYCP</sub>	-	ns
SCK ↑ → SOT delay time	t <sub>SHOVI</sub>	SCKx SOTx		-30	+30	- 20	+ 20	ns
SIN → SCK ↓ setup time	t <sub>IVSLI</sub>	SCKx SINx		50	-	30	-	ns
SCK ↓ → SIN hold time	t <sub>SLIXI</sub>	SCKx SINx		0	-	0	-	ns
SOT → SCK ↓ delay time	t <sub>SOVLI</sub>	SCKx SOTx		2t <sub>CYCP</sub> - 30	-	2t <sub>CYCP</sub> - 30	-	ns
Serial clock "L" pulse width	t <sub>SLSH</sub>	SCKx		2t <sub>CYCP</sub> - 10	-	2t <sub>CYCP</sub> - 10	-	ns
Serial clock "H" pulse width	t <sub>SHSL</sub>	SCKx	t <sub>CYCP</sub> + 10	-	t <sub>CYCP</sub> + 10	-	ns	
SCK ↑ → SOT delay time	t <sub>SHOVE</sub>	SCKx SOTx	Slave mode	-	50	-	30	ns
SIN → SCK ↓ setup time	t <sub>IVSLE</sub>	SCKx SINx		10	-	10	-	ns
SCK ↓ → SIN hold time	t <sub>SLIXE</sub>	SCKx SINx		20	-	20	-	ns
SCK fall time	t <sub>F</sub>	SCKx		-	5	-	5	ns
SCK rise time	t <sub>R</sub>	SCKx		-	5	-	5	ns

**Notes:**

- The above characteristics apply to CLK synchronous mode.
- t<sub>CYCP</sub> indicates the APB bus clock cycle time.  
About the APB bus number which Multi-function Serial is connected to, see "Block Diagram" in this Datasheet.
- These characteristics only guarantee the same relocate port number.  
For example, the combination of SCKx\_0 and SOTx\_1 is not guaranteed.
- When the external load capacitance = 30 pF.

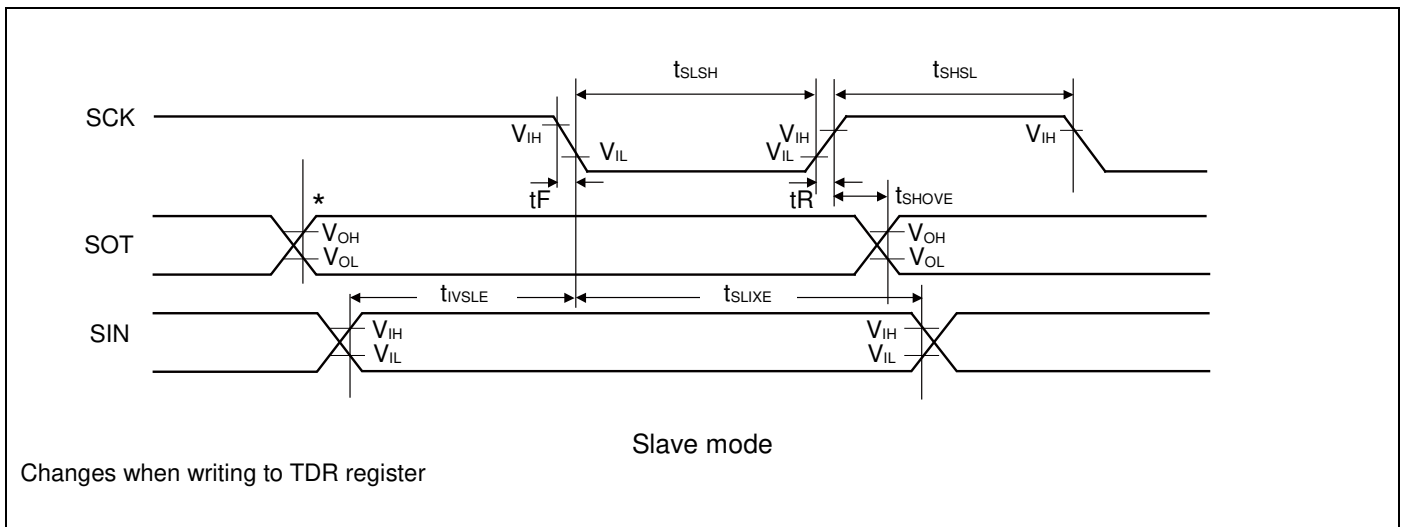
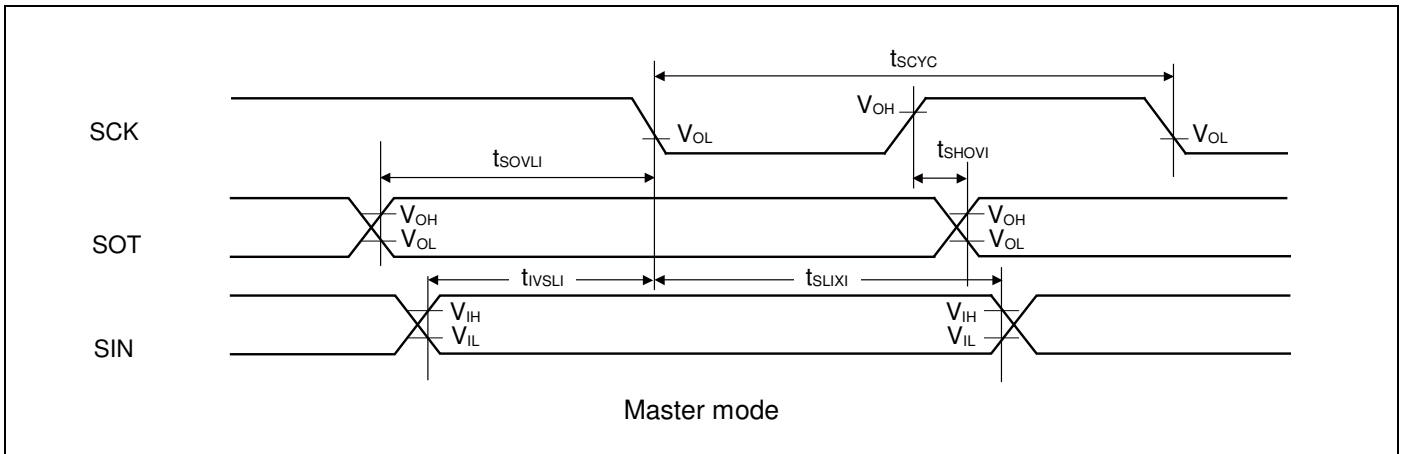

**CSIO (SPI = 1, SCINV = 1)**

 (V<sub>CC</sub> = 2.7V to 5.5V, V<sub>SS</sub> = 0V, T<sub>A</sub> = - 40°C to + 105°C)

Parameter	Symbol	Pin name	Conditions	V <sub>CC</sub> < 4.5 V		V <sub>CC</sub> ≥ 4.5 V		Unit
				Min	Max	Min	Max	
Baud rate	-	-	-	-	8	-	8	Mbps
Serial clock cycle time	t <sub>SCYC</sub>	SCKx	Master mode	4t <sub>CYCP</sub>	-	4t <sub>CYCP</sub>	-	ns
SCK ↓ → SOT delay time	t <sub>SLOVI</sub>	SCKx SOTx		-30	+30	- 20	+ 20	ns
SIN → SCK ↑ setup time	t <sub>IVSHI</sub>	SCKx SINx		50	-	30	-	ns
SCK ↑ → SIN hold time	t <sub>SHIXI</sub>	SCKx SINx		0	-	0	-	ns
SOT → SCK ↑ delay time	t <sub>SOVHI</sub>	SCKx SOTx		2t <sub>CYCP</sub> - 30	-	2t <sub>CYCP</sub> - 30	-	ns
Serial clock "L" pulse width	t <sub>LSLH</sub>	SCKx		2t <sub>CYCP</sub> - 10	-	2t <sub>CYCP</sub> - 10	-	ns
Serial clock "H" pulse width	t <sub>SHSL</sub>	SCKx	t <sub>CYCP</sub> + 10	-	t <sub>CYCP</sub> + 10	-	ns	
SCK ↓ → SOT delay time	t <sub>SLOVE</sub>	SCKx SOTx	Slave mode	-	50	-	30	ns
SIN → SCK ↑ setup time	t <sub>IVSHE</sub>	SCKx SINx		10	-	10	-	ns
SCK ↑ → SIN hold time	t <sub>SHIXE</sub>	SCKx SINx		20	-	20	-	ns
SCK fall time	t <sub>F</sub>	SCKx		-	5	-	5	ns
SCK rise time	t <sub>R</sub>	SCKx		-	5	-	5	ns

**Notes:**

- The above characteristics apply to CLK synchronous mode.
- t<sub>CYCP</sub> indicates the APB bus clock cycle time.  
About the APB bus number which Multi-function Serial is connected to, see "Block Diagram" in this datasheet.
- These characteristics only guarantee the same relocate port number.  
For example, the combination of SCKx\_0 and SOTx\_1 is not guaranteed.
- When the external load capacitance = 30 pF.

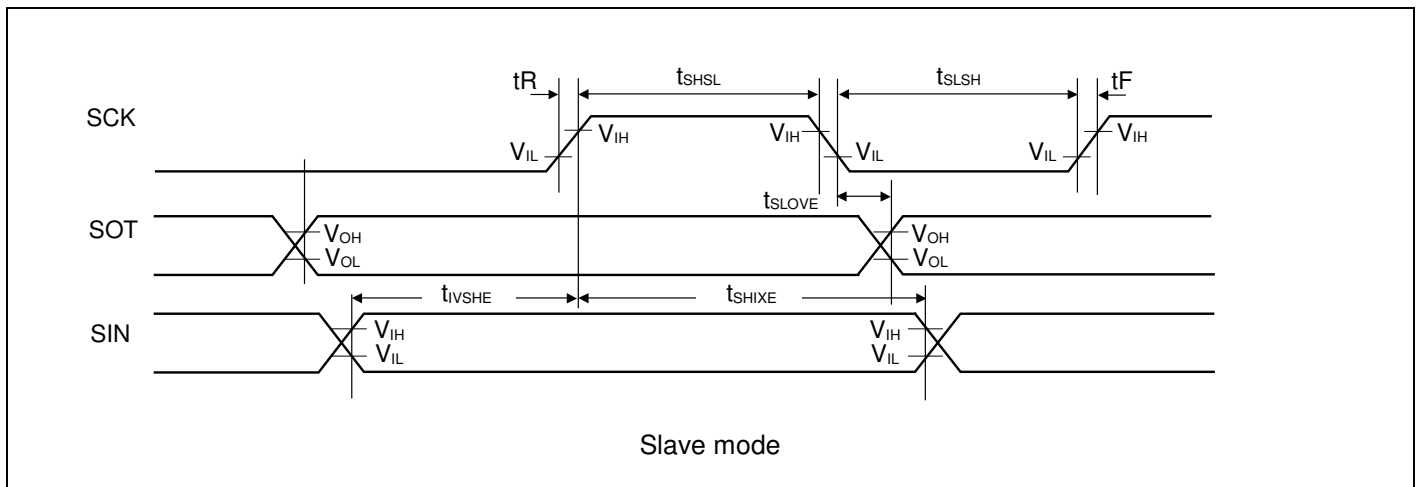
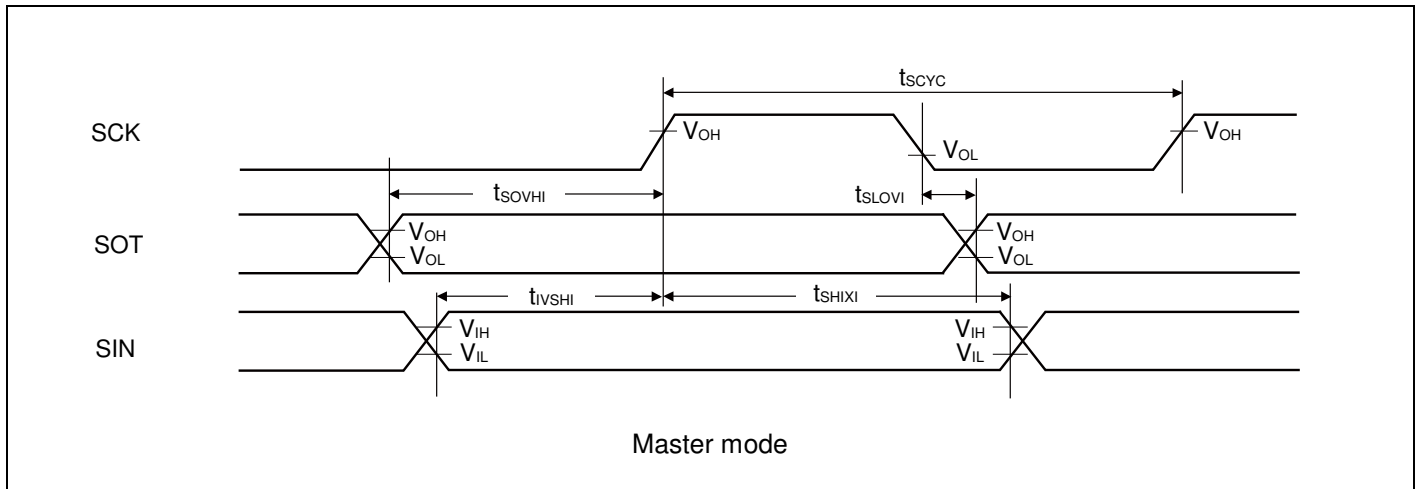
**UART external clock (EXT = 1)**

 (V<sub>CC</sub> = 2.7V to 5.5V, V<sub>SS</sub> = 0V, T<sub>A</sub> = - 40°C to + 105°C)

Parameter	Symbol	Conditions	Min	Max	Unit	Remarks
Serial clock "L" pulse width	t <sub>SLSH</sub>	C <sub>L</sub> = 30 pF	t <sub>CYCP</sub> + 10	-	ns	
Serial clock "H" pulse width	t <sub>SHSL</sub>		t <sub>CYCP</sub> + 10	-	ns	
SCK fall time	t <sub>F</sub>		-	5	ns	
SCK rise time	t <sub>R</sub>		-	5	ns	

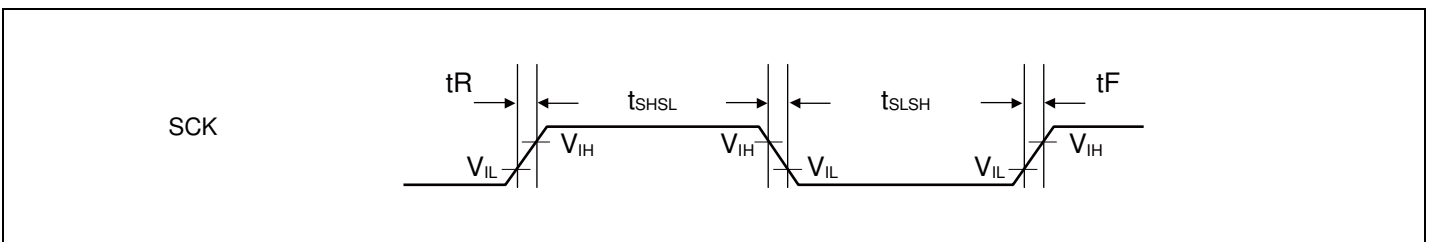

## 12.4.10 External Input Timing

(V<sub>CC</sub> = 2.7V to 5.5V, V<sub>SS</sub> = 0V, T<sub>A</sub> = - 40°C to + 105°C)

Parameter	Symbol	Pin name	Conditions	Value		Unit	Remarks
				Min	Max		
Input pulse width	t <sub>INH</sub> , t <sub>INL</sub>	ADTG	-	2t <sub>CYCP</sub> <sup>*1</sup>	-	ns	A/D converter trigger input
		FRCKx					Free-run timer input clock
		ICxx					Input capture
		DTTIXX	-	2t <sub>CYCP</sub> <sup>*1</sup>	-	ns	Wave form generator
		INTxx	*2	2t <sub>CYCP</sub> + 100 <sup>*1</sup>	-	ns	External interrupt
		NMIX	*3	500	-	ns	NMI
WKUPx	*4	820	-	ns	Deep stand-by wake up		

\*1: t<sub>CYCP</sub> indicates the APB bus clock cycle time.

About the APB bus number which A/D converter, Multi-function Timer, External interrupt are connected to, see "Block Diagram" in this Datasheet.

\*2: When in run mode, in sleep mode.

\*3: When in stop mode, in rtc mode, in timer mode.

\*4: When in deep stand-by stop mode, in deep stand-by rtc mode.

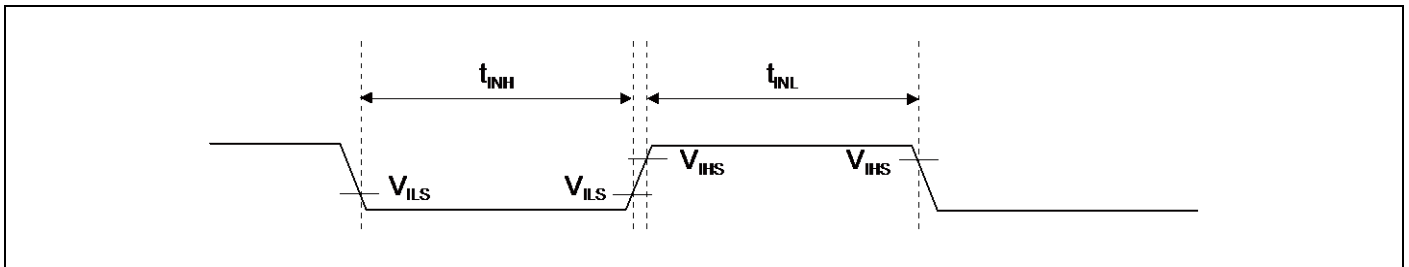

## 12.4.11 Quadrature Position/Revolution Counter timing

(V<sub>CC</sub> = 2.7V to 5.5V, V<sub>SS</sub> = 0V, T<sub>A</sub> = - 40°C to + 105°C)

Parameter	Symbol	Conditions	Value		Unit
			Min	Max	
AIN pin "H" width	t <sub>AHL</sub>	-	2t <sub>CYCP</sub> <sup>*1</sup>	-	ns
AIN pin "L" width	t <sub>ALL</sub>	-			
BIN pin "H" width	t <sub>BHL</sub>	-			
BIN pin "L" width	t <sub>BLL</sub>	-			
BIN rise time from AIN pin "H" level	t <sub>AUBU</sub>	PC_Mode2 or PC_Mode3			
AIN fall time from BIN pin "H" level	t <sub>BUAD</sub>	PC_Mode2 or PC_Mode3			
BIN fall time from AIN pin "L" level	t <sub>ADBD</sub>	PC_Mode2 or PC_Mode3			
AIN rise time from BIN pin "L" level	t <sub>BDAU</sub>	PC_Mode2 or PC_Mode3			
AIN rise time from BIN pin "H" level	t <sub>BUAU</sub>	PC_Mode2 or PC_Mode3			
BIN fall time from AIN pin "H" level	t <sub>AUBD</sub>	PC_Mode2 or PC_Mode3			
AIN fall time from BIN pin "L" level	t <sub>BDAD</sub>	PC_Mode2 or PC_Mode3			
BIN rise time from AIN pin "L" level	t <sub>ADBU</sub>	PC_Mode2 or PC_Mode3			
ZIN pin "H" width	t <sub>ZHL</sub>	QCR:CGSC = "0"			
ZIN pin "L" width	t <sub>ZLL</sub>	QCR:CGSC = "0"			
AIN/BIN rise and fall time from determined ZIN level	t <sub>ZABE</sub>	QCR:CGSC = "1"			
Determined ZIN level from AIN/BIN rise and fall time	t <sub>ABEZ</sub>	QCR:CGSC = "1"			

\*1: t<sub>CYCP</sub> indicates the APB bus clock cycle time.

About the APB bus number which Quadrature Position/Revolution Counter is connected to, see "Block Diagram" in this Datasheet.

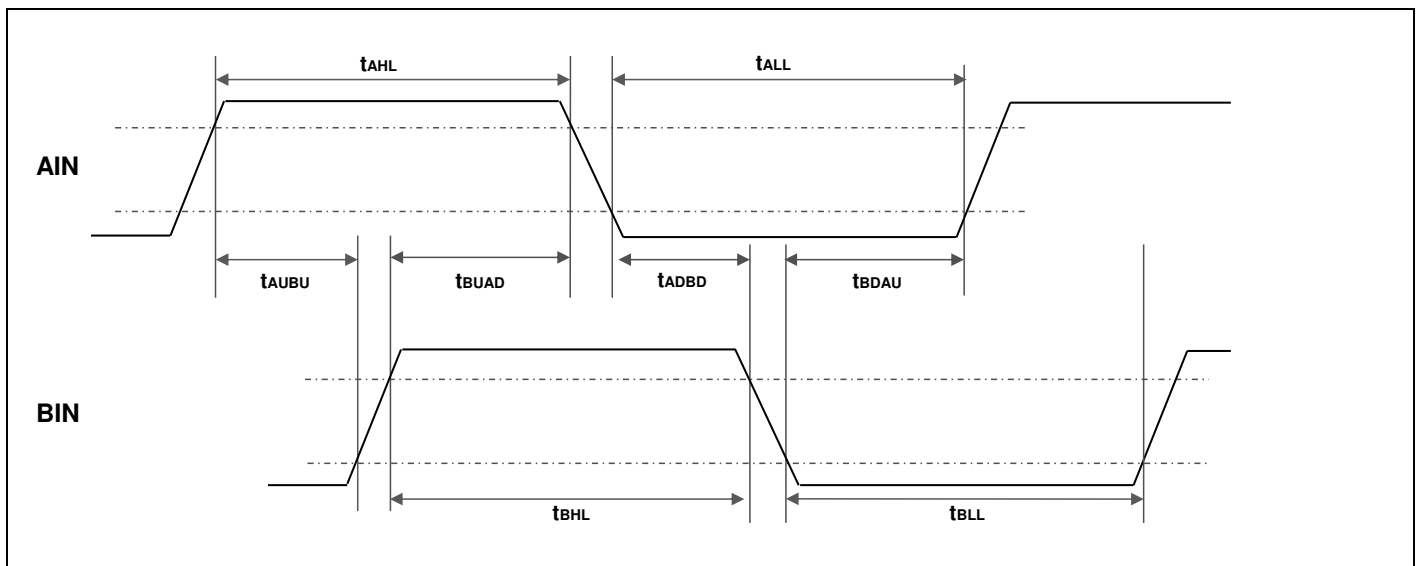



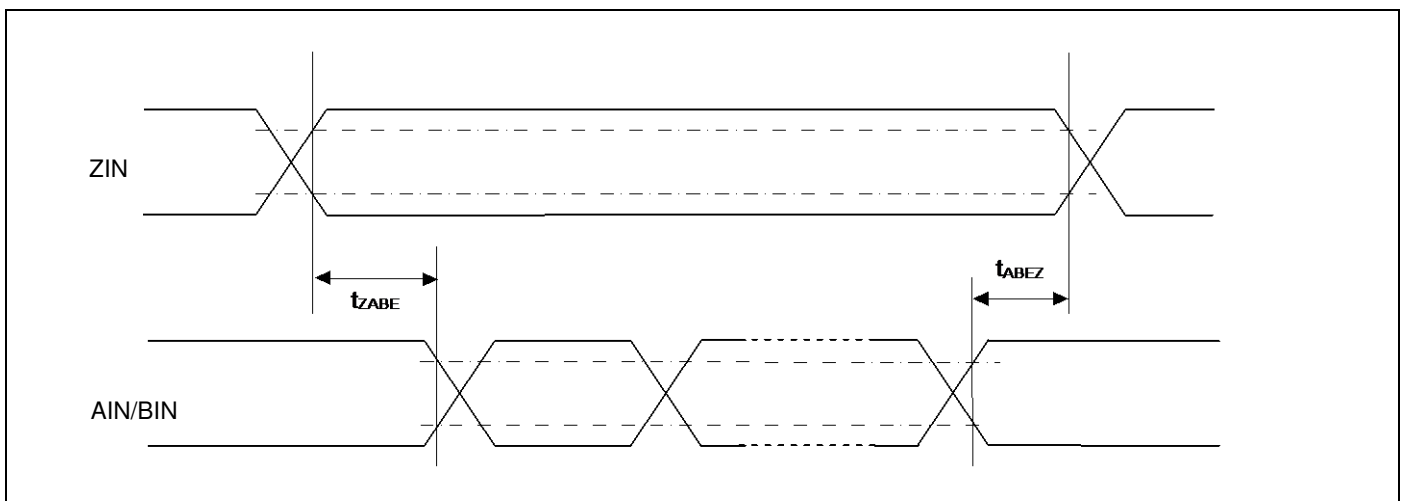
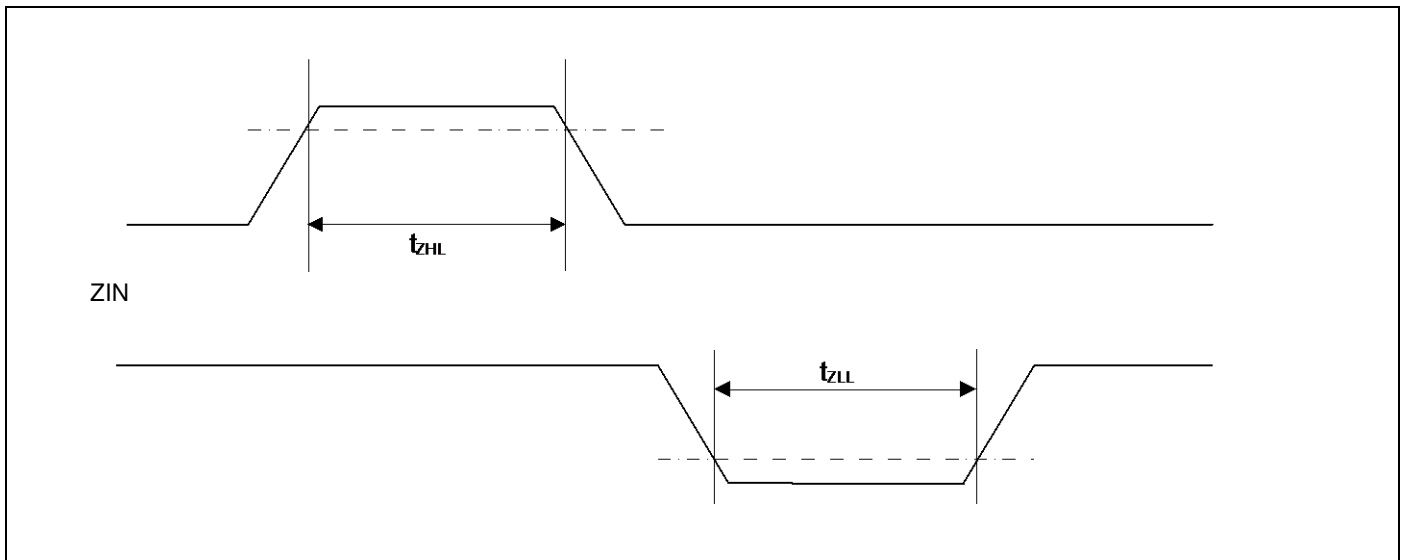
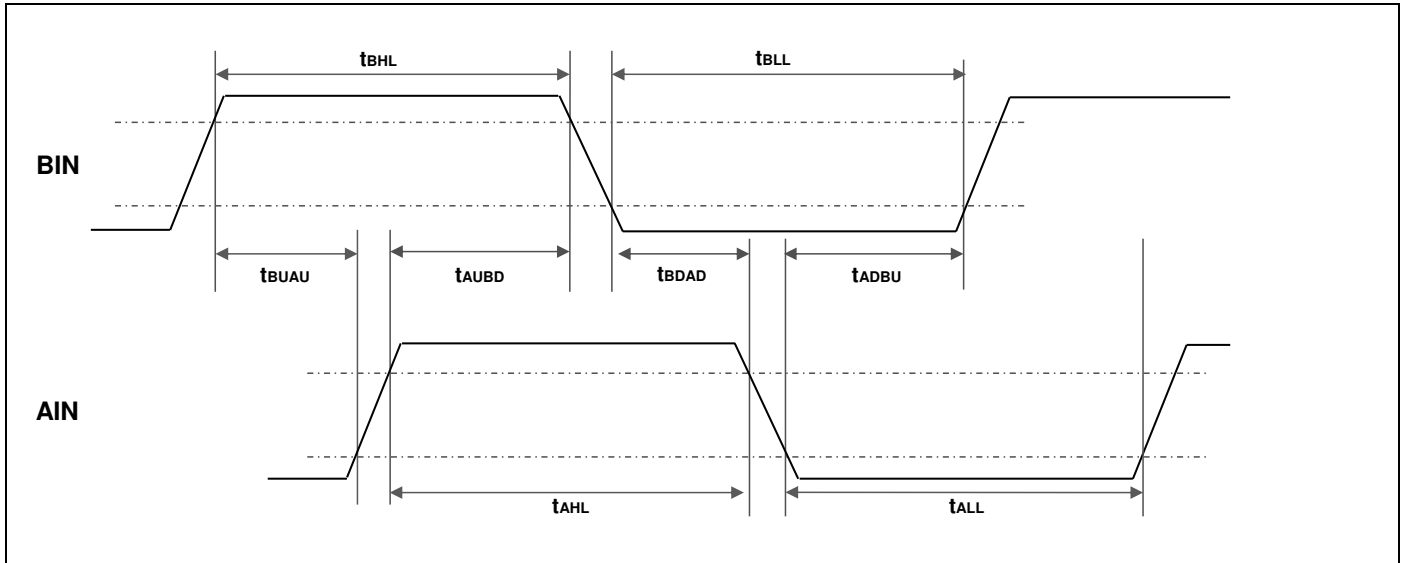

## 12.4.12 I<sup>2</sup>C Timing

(V<sub>CC</sub> = 2.7V to 5.5V, V<sub>SS</sub> = 0V, T<sub>A</sub> = - 40°C to + 105°C)

Parameter	Symbol	Conditions	Standard-mode		Fast-mode		Unit	Remarks
			Min	Max	Min	Max		
SCL clock frequency	F <sub>SCL</sub>		0	100	0	400	kHz	
(Repeated) START condition hold time SDA ↓ → SCL ↓	t <sub>HDSTA</sub>	C <sub>L</sub> = 30pF, R = (V <sub>p</sub> /I <sub>OL</sub> ) <sup>*1</sup>	4.0	-	0.6	-	μs	
SCLclock "L" width	t <sub>LOW</sub>		4.7	-	1.3	-	μs	
SCLclock "H" width	t <sub>HIGH</sub>		4.0	-	0.6	-	μs	
(Repeated) START setup time SCL ↑ → SDA ↓	t <sub>SUSTA</sub>		4.7	-	0.6	-	μs	
Data hold time SCL ↓ → SDA ↓ ↑	t <sub>HDDAT</sub>		0	3.45 <sup>*2</sup>	0	0.9 <sup>*3</sup>	μs	
Data setup time SDA ↓ ↑ → SCL ↑	t <sub>SUDAT</sub>		250	-	100	-	ns	
STOP condition setup time SCL ↑ → SDA ↑	t <sub>SUSTO</sub>		4.0	-	0.6	-	μs	
Bus free time between "STOP condition" and "START condition"	t <sub>BUF</sub>		4.7	-	1.3	-	μs	
Noise filter	t <sub>SP</sub>		-	2 t <sub>CYCP</sub> <sup>*4</sup>	-	2 t <sub>CYCP</sub> <sup>*4</sup>	-	ns

\*1: R and C represent the pull-up resistance and load capacitance of the SCL and SDA lines, respectively.

V<sub>p</sub> indicates the power supply voltage of the pull-up resistance and I<sub>OL</sub> indicates V<sub>OL</sub> guaranteed current.

\*2: The maximum t<sub>HDDAT</sub> must satisfy that it doesn't extend at least "L" period (t<sub>LOW</sub>) of device's SCL signal.

\*3: Fast-mode I<sup>2</sup>C bus device can be used on Standard-mode I<sup>2</sup>C bus system as long as the device satisfies the requirement of "t<sub>SUDAT</sub> ≥ 250 ns".

\*4: t<sub>CYCP</sub> is the APB bus clock cycle time.

About the APB bus number that I<sup>2</sup>C is connected to, see "Block Diagram" in this Datasheet.

To use Standard-mode, set the APB bus clock at 2 MHz or more.

To use Fast-mode, set the APB bus clock at 8 MHz or more.

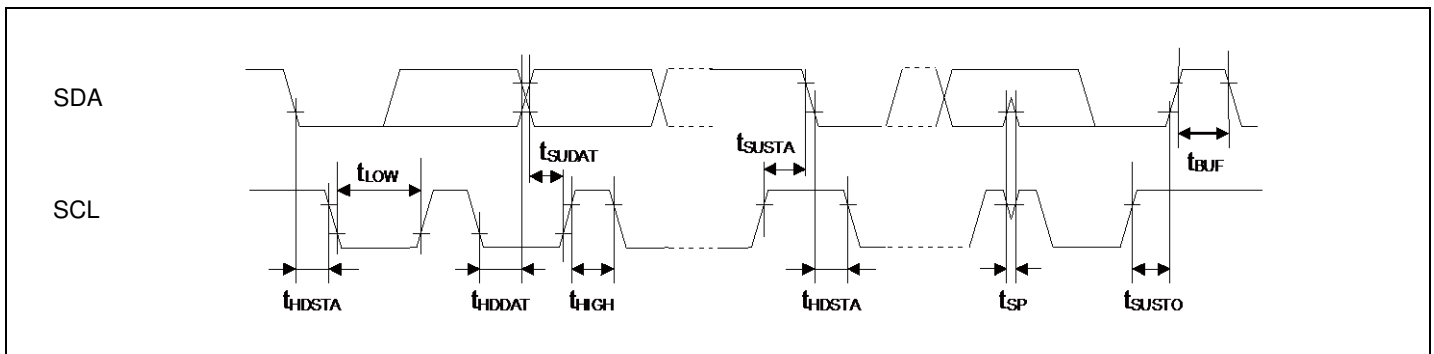

## 12.4.13 JTAG Timing

( $V_{CC} = 2.7V$  to  $5.5V$ ,  $V_{SS} = 0V$ ,  $T_A = -40^{\circ}C$  to  $+105^{\circ}C$ )

Parameter	Symbol	Pin name	Conditions	Value		Unit	Remarks
				Min	Max		
TMS, TDI setup time	$t_{JTAGS}$	TCK, TMS, TDI	$V_{CC} \geq 4.5 V$	15	-	ns	
			$V_{CC} < 4.5 V$				
TMS, TDI hold time	$t_{JTAGH}$	TCK, TMS, TDI	$V_{CC} \geq 4.5 V$	15	-	ns	
			$V_{CC} < 4.5 V$				
TDO delay time	$t_{JTAGD}$	TCK, TDO	$V_{CC} \geq 4.5 V$	-	25	ns	
			$V_{CC} < 4.5 V$	-	45		

**Note:**

- When the external load capacitance = 30 pF.

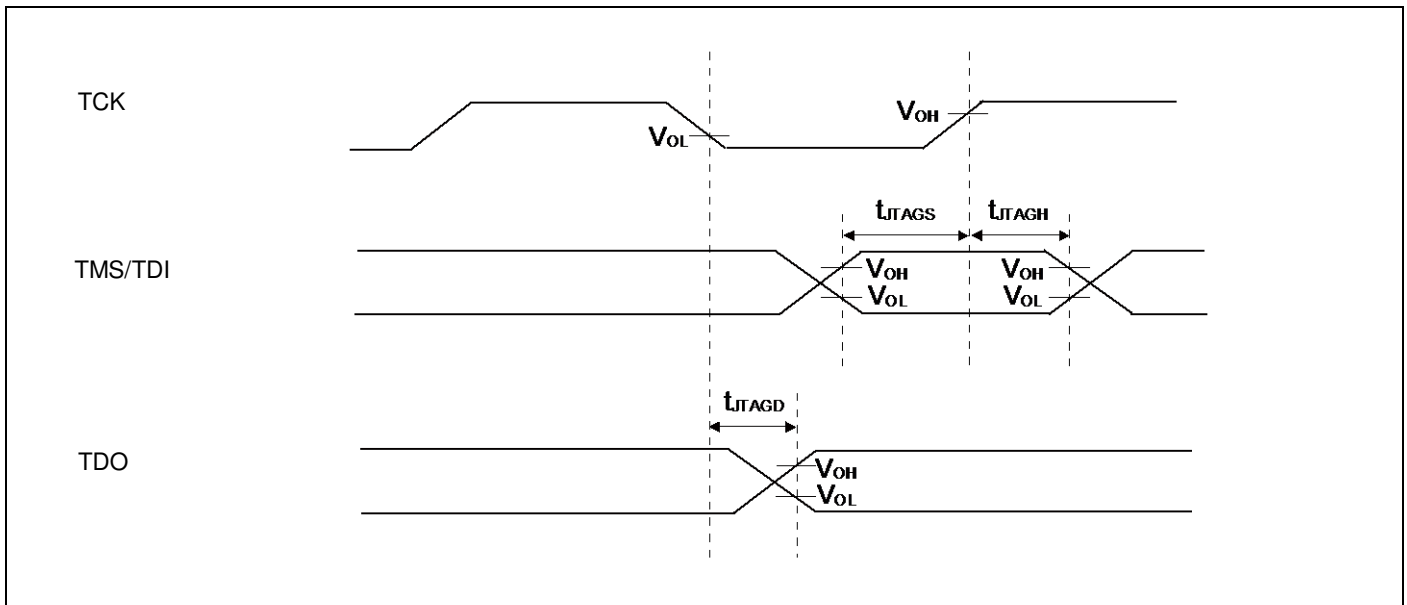

## 12.5 12-bit A/D Converter

### Electrical characteristics for the A/D converter

( $V_{CC} = AV_{CC} = 2.7V$  to  $5.5V$ ,  $V_{SS} = AV_{SS} = 0V$ ,  $T_A = -40^{\circ}C$  to  $+105^{\circ}C$ )

Parameter	Symbol	Pin name	Value			Unit	Remarks
			Min	Typ	Max		
Resolution	-	-	-	-	12	bit	
Integral nonlinearity	-	-	- 4.5	-	+ 4.5	LSB	AVRH = 2.7 V to 5.5 V
Differential nonlinearity	-	-	-2.5	-	+ 2.5	LSB	
Zero transition voltage	$V_{ZT}$	ANxx	- 20	-	+ 20	mV	
Full-scale transition voltage	$V_{FST}$	ANxx	AVRH - 20	-	AVRH + 20	mV	
Conversion time	-	-	$1.0^{*1}$	-	-	$\mu s$	AVcc $\geq$ 4.5 V
			$1.2^{*1}$	-	-		AVcc < 4.5 V
Sampling time	$T_s$	-	*2	-	-	ns	AVcc $\geq$ 4.5 V
			*2	-	-		AVcc < 4.5 V
Compare clock cycle <sup>*3</sup>	$T_{cck}$	-	50	-	2000	ns	
State transition time to operation permission	$T_{stt}$	-	-	-	1.0	$\mu s$	
Analog input capacity	$C_{AIN}$	-	-	-	12.9	pF	
Analog input resistance	$R_{AIN}$	-	-	-	2	k $\Omega$	AVcc $\geq$ 4.5 V
					3.8		AVcc < 4.5 V
Interchannel disparity	-	-	-	-	4	LSB	
Analog port input leak current	-	ANxx	-	-	5	$\mu A$	
Analog input voltage	-	ANxx	AVSS	-	AVRH	V	
Reference voltage	-	AVRH	2.7	-	AVCC	V	

\*1: Conversion time is the value of sampling time ( $T_s$ ) + compare time ( $T_c$ ).

The condition of the minimum conversion time is the following.

AVcc  $\geq$  4.5V, HCLK = 40 MHz    sampling time: 300 ns, compare time: 700 ns

AVcc < 4.5V, HCLK = 40 MHz    sampling time: 500 ns, compare time: 700 ns

Ensure that it satisfies the value of sampling time ( $T_s$ ) and compare clock cycle ( $T_{cck}$ ).

For setting of sampling time and compare clock cycle, see "Chapter 1-1:A/D Converter" in "FM3 Family Peripheral Manual Analog Macro Part".

The A/D Converter register is set at APB bus clock timing. The sampling clock and compare clock are set at Base clock (HCLK).

About the APB bus number which the A/D Converter is connected to, see "Block Diagram" in this Datasheet.

\*2: A necessary sampling time changes by external impedance.

Ensure that it set the sampling time to satisfy (Equation 1).

\*3: Compare time ( $T_c$ ) is the value of (Equation 2).

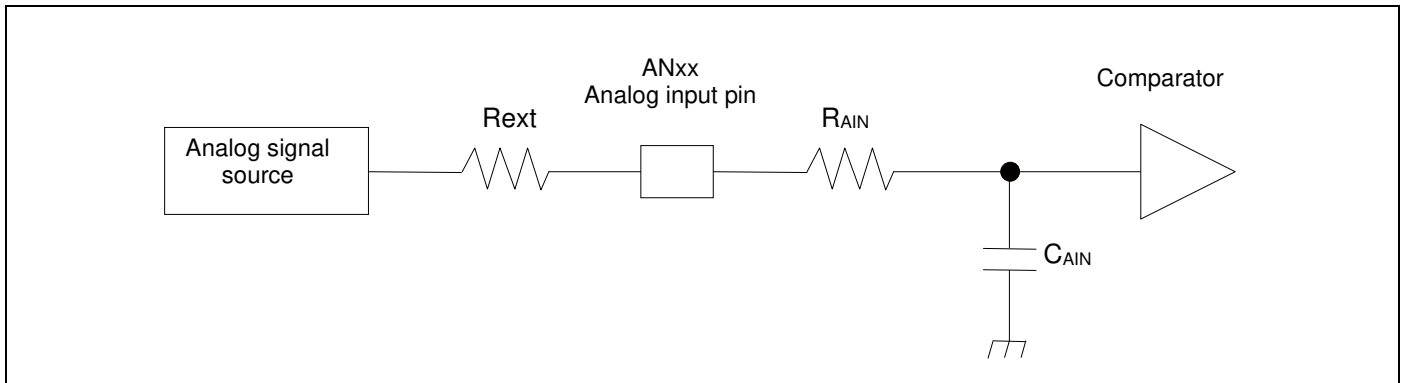

(Equation 1)  $T_s \geq (R_{AIN} + R_{ext}) \times C_{AIN} \times 9$

T<sub>s</sub>: Sampling time

R<sub>AIN</sub>: Input resistance of A/D = 2kΩ at 4.5 V ≤ AV<sub>CC</sub> ≤ 5.5 V  
 Input resistance of A/D = 3.8kΩ at 2.7 V ≤ AV<sub>CC</sub> ≤ 4.5 V

C<sub>AIN</sub>: Input capacity of A/D = 12.9pF at 2.7 V ≤ AV<sub>CC</sub> ≤ 5.5 V

R<sub>ext</sub>: Output impedance of external circuit

(Equation 2)  $T_c = T_{cck} \times 14$

T<sub>c</sub>: Compare time

T<sub>cck</sub>: Compare clock cycle

**Definition of 12-bit A/D Converter Terms**

- Resolution: Analog variation that is recognized by an A/D converter.
- Integral nonlinearity: Deviation of the line between the zero-transition point (0b000000000000 ←→ 0b000000000001) and the full-scale transition point (0b111111111110 ←→ 0b111111111111) from the actual conversion characteristics.
- Differential nonlinearity: Deviation from the ideal value of the input voltage that is required to change the output code by 1 LSB.

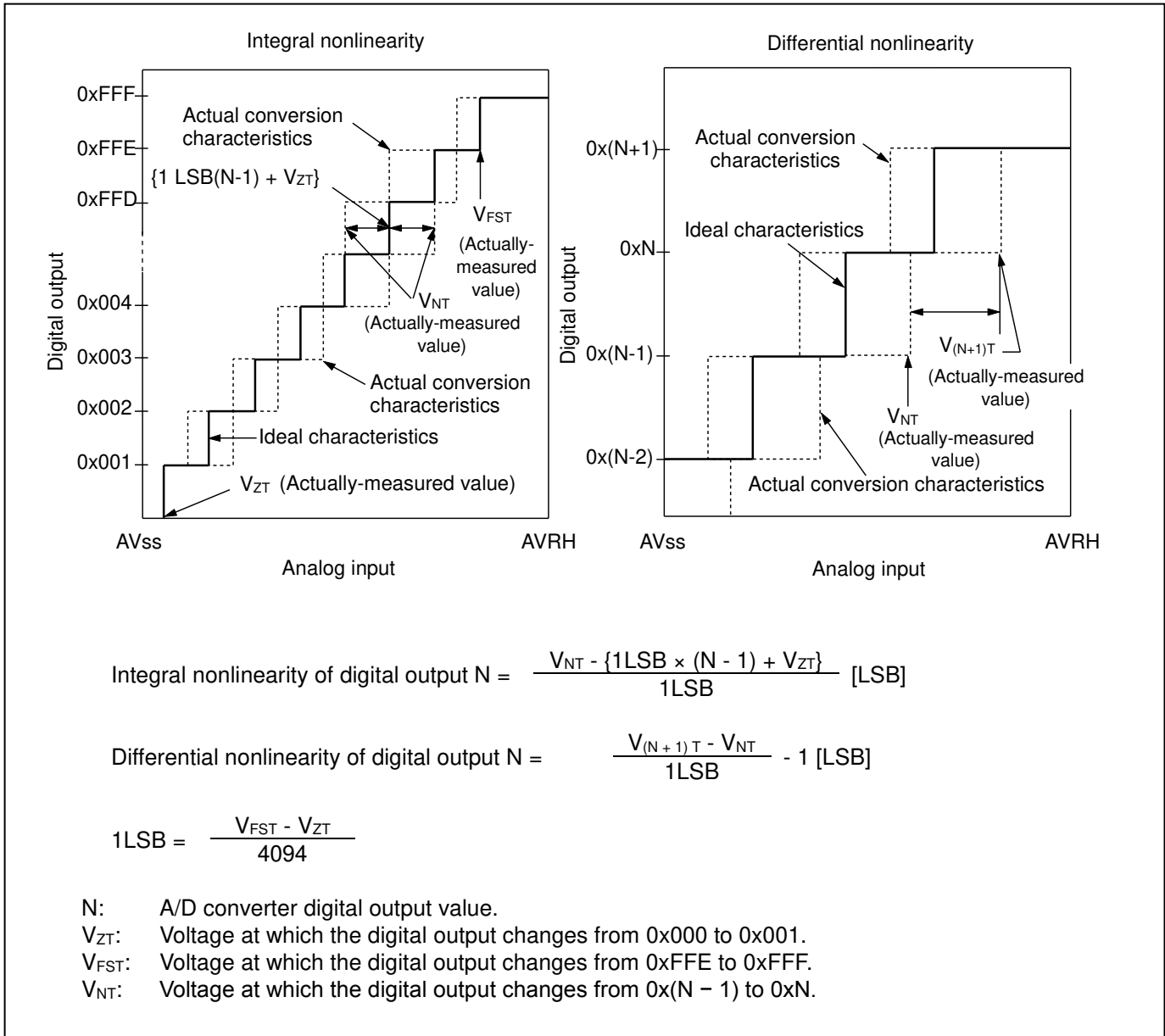

## 12.6 USB Characteristics

(V<sub>CC</sub> = 2.7V to 5.5V, USBV<sub>CC</sub> = 3.0V to 3.6V, V<sub>SS</sub> = 0V, T<sub>A</sub> = - 40°C to + 105°C)

Parameter	Symbol	Pin name	Conditions	Value		Unit	Remarks	
				Min	Max			
Input characteristics	Input "H" level voltage	V <sub>IH</sub>	-	2.0	USBV <sub>CC</sub> + 0.3	V	*1	
	Input "L" level voltage	V <sub>IL</sub>		V <sub>SS</sub> - 0.3	0.8	V	*1	
	Differential input sensitivity	V <sub>DI</sub>		0.2	-	V	*2	
	Different common mode input voltage	V <sub>CM</sub>		0.8	2.5	V	*2	
Output characteristics	Output "H" level voltage	V <sub>OH</sub>	UDP0, UDM0	2.8	3.6	V	*3	
	Output "L" level voltage	V <sub>OL</sub>		External pull-down resistance = 15 kΩ	0.0	0.3	V	*3
	Crossover voltage	V <sub>CRS</sub>		-	1.3	2.0	V	*4
	Rise time	t <sub>FR</sub>		Full-Speed	4	20	ns	*5
	Fall time	t <sub>FF</sub>		Full-Speed	4	20	ns	*5
	Rise/ fall time matching	t <sub>FRFM</sub>		Full-Speed	90	111.11	%	*5
	Output impedance	Z <sub>DRV</sub>		Full-Speed	28	44	Ω	*6
	Rise time	t <sub>LR</sub>		Low-Speed	75	300	ns	*7
	Fall time	t <sub>LF</sub>		Low-Speed	75	300	ns	*7
	Rise/ fall time matching	t <sub>LRFM</sub>		Low-Speed	80	125	%	*7

\*1: The switching threshold voltage of Single-End-Receiver of USB I/O buffer is set as within V<sub>IL</sub> (Max) = 0.8V, V<sub>IH</sub> (Min) = 2.0 V (TTL input standard).

There are some hysteresis to lower noise sensitivity.

\*2: Use differential-Receiver to receive USB differential data signal.

Differential-Receiver has 200 mV of differential input sensitivity when the differential data input is within 0.8 V to 2.5 V to the local ground reference level.

Above voltage range is the common mode input voltage range.

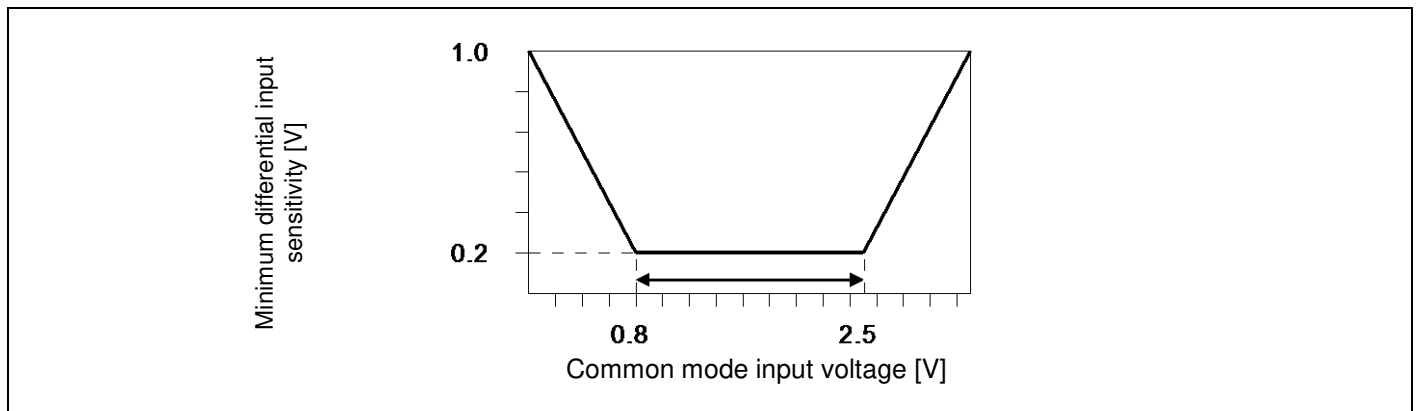

\*3: The output drive capability of the driver is below 0.3 V at Low-State ( $V_{OL}$ ) (to 3.6 V and 1.5 k $\Omega$  load), and 2.8 V or above (to the VSS and 1.5 k $\Omega$  load) at High-State ( $V_{OH}$ ).

\*4: The cross voltage of the external differential output signal (D + /D - ) of USB I/O buffer is within 1.3 V to 2.0 V.

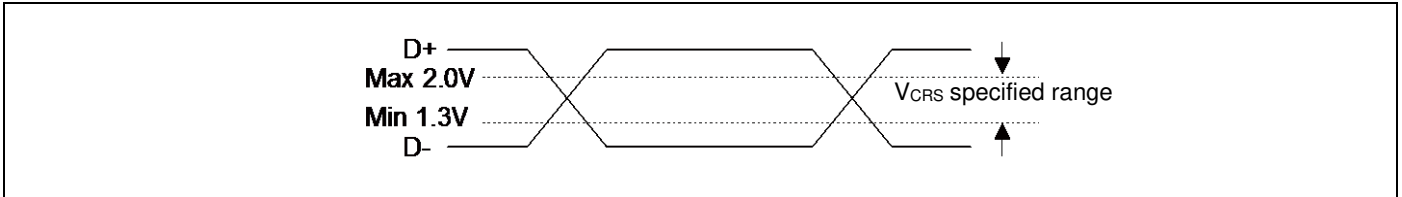

\*5: They indicate rise time ( $T_{rise}$ ) and fall time ( $T_{fall}$ ) of the full-speed differential data signal. They are defined by the time between 10% and 90% of the output signal voltage. For full-speed buffer,  $T_r/T_f$  ratio is regulated as within  $\pm 10\%$  to minimize RFI emission.

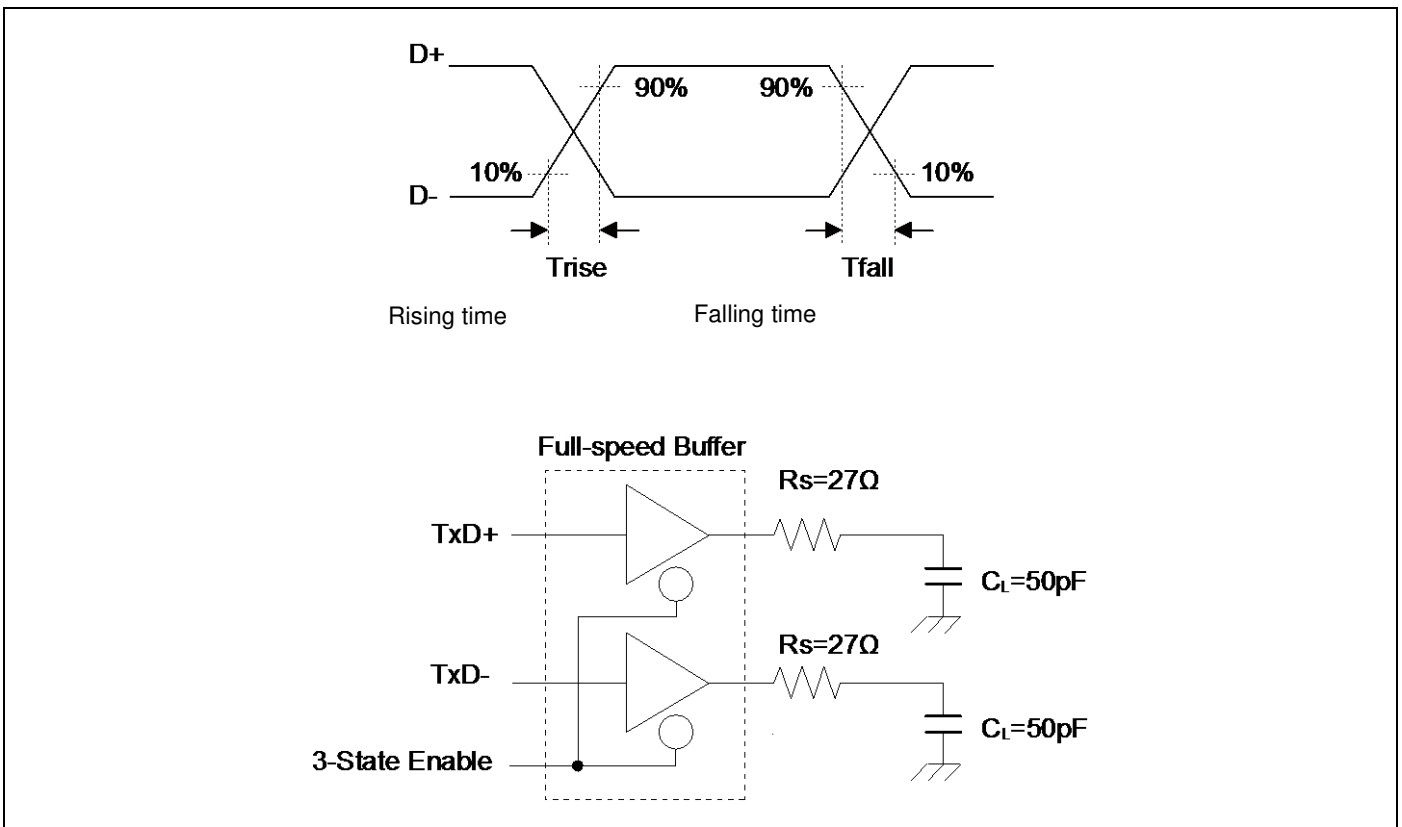



\*6: USB Full-speed connection is performed via twist pair cable shield with  $90\Omega \pm 15\%$  characteristic impedance (Differential Mode).  
 USB standard defines that output impedance of USB driver must be in range from  $28\Omega$  to  $44\Omega$ . So, discrete series resistor ( $R_s$ ) addition is defined in order to satisfy the above definition and keep balance.  
 When using this USB I/O, use it with  $25\Omega$  to  $30\Omega$  (recommendation value  $27\Omega$ ) Series resistor  $R_s$ .

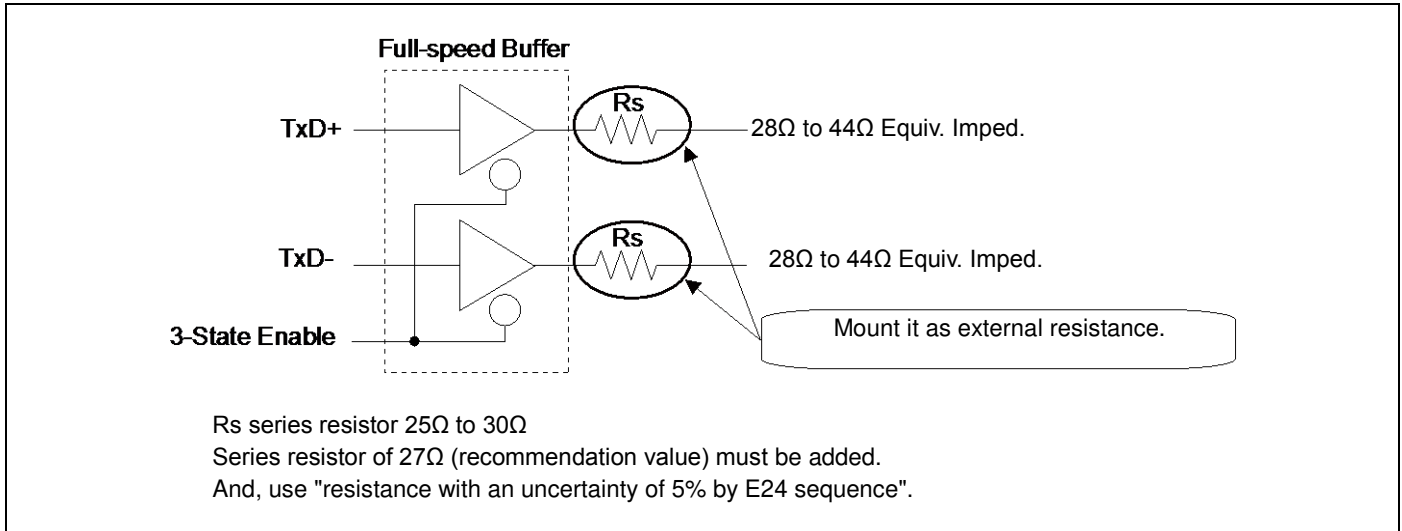

\*7: They indicate rise time ( $T_{rise}$ ) and fall time ( $T_{fall}$ ) of the low-speed differential data signal.  
 They are defined by the time between 10% and 90% of the output signal voltage.

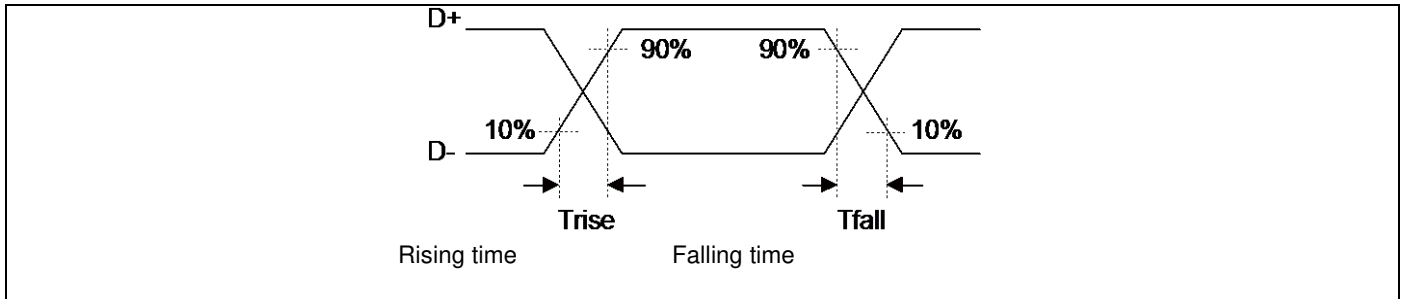

See Figure "Low-Speed Load (Compliance Load)" for conditions of external load.

**Low-Speed Load (Upstream Port Load) - Reference 1**

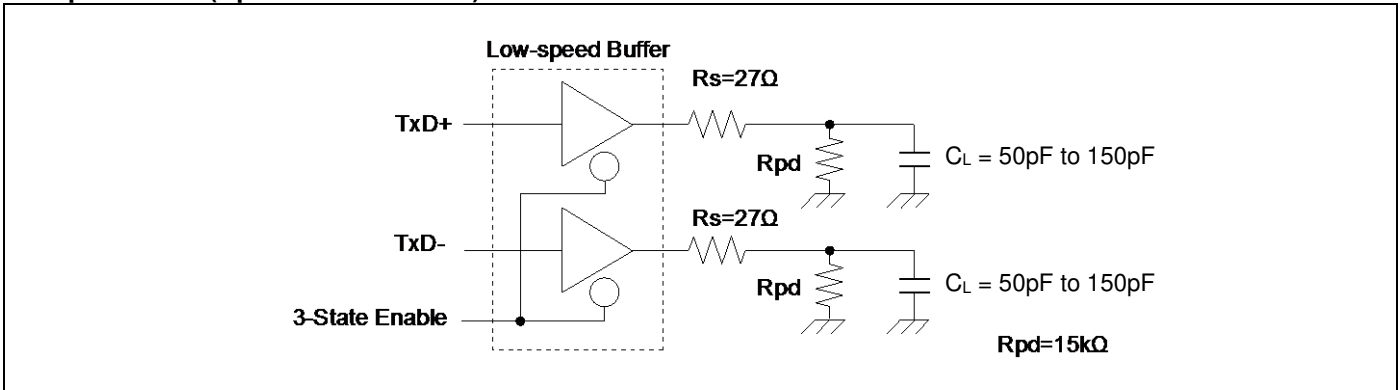

**Low-Speed Load (Downstream Port Load) - Reference 2**

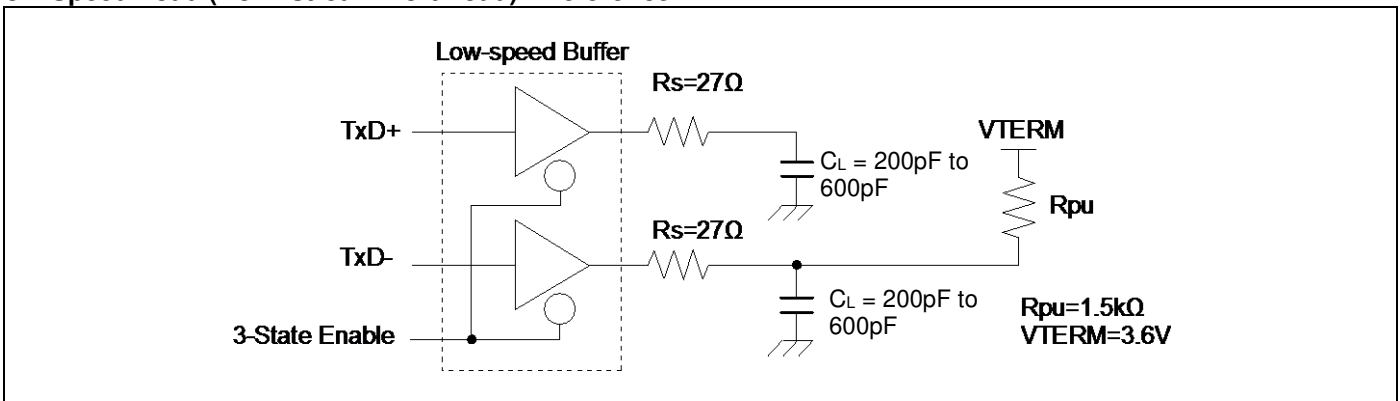

**Low-Speed Load (Compliance Load)**

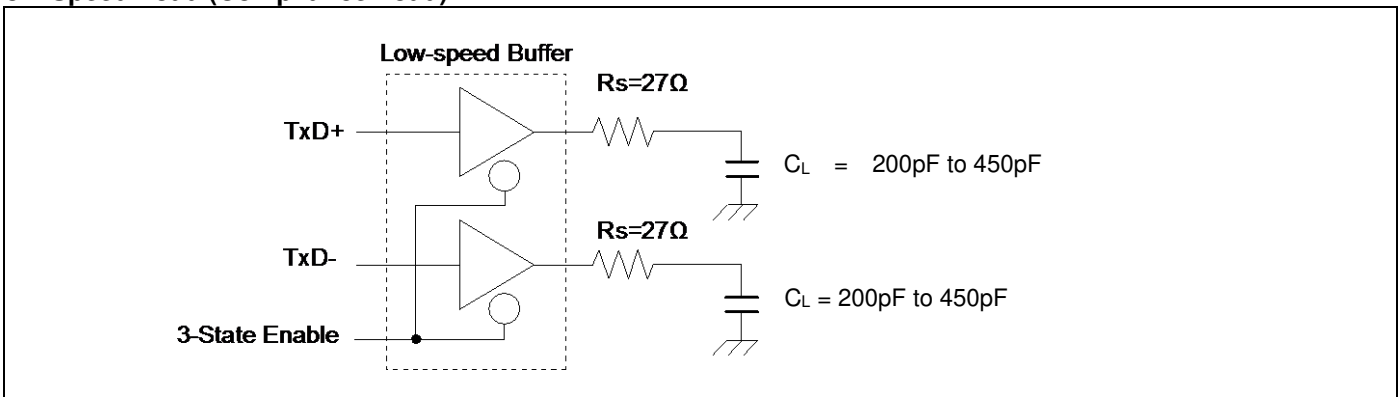

## 12.7 Low-voltage Detection Characteristics

### 12.7.1 Low-voltage Detection Reset

 $(T_A = -40^\circ\text{C to } +105^\circ\text{C})$ 

Parameter	Symbol	Conditions	Value			Unit	Remarks
			Min	Typ	Max		
Detected voltage	VDL	-	2.25	2.45	2.65	V	When voltage drops
Released voltage	VDH	-	2.30	2.50	2.70	V	When voltage rises

### 12.7.2 Interrupt of Low-voltage Detection

 $(T_A = -40^\circ\text{C to } +105^\circ\text{C})$ 

Parameter	Symbol	Conditions	Value			Unit	Remarks
			Min	Typ	Max		
Detected voltage	VDL	SVHI = 0000	2.58	2.8	3.02	V	When voltage drops
Released voltage	VDH		2.67	2.9	3.13	V	When voltage rises
Detected voltage	VDL	SVHI = 0001	2.76	3.0	3.24	V	When voltage drops
Released voltage	VDH		2.85	3.1	3.34	V	When voltage rises
Detected voltage	VDL	SVHI = 0010	2.94	3.2	3.45	V	When voltage drops
Released voltage	VDH		3.04	3.3	3.56	V	When voltage rises
Detected voltage	VDL	SVHI = 0011	3.31	3.6	3.88	V	When voltage drops
Released voltage	VDH		3.40	3.7	3.99	V	When voltage rises
Detected voltage	VDL	SVHI = 0100	3.40	3.7	3.99	V	When voltage drops
Released voltage	VDH		3.50	3.8	4.10	V	When voltage rises
Detected voltage	VDL	SVHI = 0111	3.68	4.0	4.32	V	When voltage drops
Released voltage	VDH		3.77	4.1	4.42	V	When voltage rises
Detected voltage	VDL	SVHI = 1000	3.77	4.1	4.42	V	When voltage drops
Released voltage	VDH		3.86	4.2	4.53	V	When voltage rises
Detected voltage	VDL	SVHI = 1001	3.86	4.2	4.53	V	When voltage drops
Released voltage	VDH		3.96	4.3	4.64	V	When voltage rises
LVD stabilization wait time	$T_{LVDW}$	-	-	-	$2240 \times t_{CYCP}^{*1}$	$\mu\text{s}$	

\*1:  $t_{CYCP}$  indicates the APB2 bus clock cycle time.

## 12.8 MainFlash Memory Write/Erase Characteristics

### 12.8.1 Write / Erase time

(V<sub>CC</sub> = 2.7V to 5.5V, T<sub>A</sub> = - 40°C to + 105°C)

Parameter		Value		Unit	Remarks
		Typ <sup>*1</sup>	Max <sup>*1</sup>		
Sector erase time	Large Sector	0.7	3.7	s	Includes write time prior to internal erase
	Small Sector	0.3	1.1		
Half word (16-bit) write time		12	384	μs	Not including system-level overhead time
Chip erase time		3.8	16.2	s	Includes write time prior to internal erase

\*1: The typical value is immediately after shipment, the maximum value is guarantee value under 100,000 cycle of erase/write.

### 12.8.2 Erase/write cycles and data hold time

Erase/write cycles (cycle)	Data hold time (year)
1,000	20 <sup>*1</sup>
10,000	10 <sup>*1</sup>
100,000	5 <sup>*1</sup>

\*1: At average + 85°C

## 12.9 WorkFlash Memory Write/Erase Characteristics

### 12.9.1 Write / Erase time

(V<sub>CC</sub> = 2.7V to 5.5V, T<sub>A</sub> = - 40°C to + 105°C)

Parameter		Value		Unit	Remarks
		Typ <sup>*1</sup>	Max <sup>*1</sup>		
Sector erase time		0.3	1.5	s	Includes write time prior to internal erase
Half word (16-bit) write time		20	384	μs	Not including system-level overhead time
Chip erase time		1.2	6	s	Includes write time prior to internal erase

\*1: The typical value is immediately after shipment, the maximum value is guarantee value under 10,000 cycle of erase/write.

### 12.9.2 Erase/write cycles and data hold time

Erase/write cycles (cycle)	Data hold time (year)
1,000	20 <sup>*1</sup>
10,000	10 <sup>*1</sup>

\*1: At average + 85°C

**12.10 Return Time from Low-Power Consumption Mode**

**12.10.1 Return Factor: Interrupt/WKUP**

The return time from Low-Power consumption mode is indicated as follows. It is from receiving the return factor to starting the program operation.

**Return Count Time**

( $V_{CC} = 2.7V$  to  $5.5V$ ,  $T_A = -40^{\circ}C$  to  $+105^{\circ}C$ )

Parameter	Symbol	Value		Unit	Remarks
		Typ	Max*1		
SLEEP mode	Ticnt	t <sub>CVCC</sub>		ns	
High-speed CR TIMER mode, Main TIMER mode, PLL TIMER mode		40	80	μs	
Low-speed CR TIMER mode		370	740	μs	
Sub TIMER mode		699	929	μs	
STOP mode		505	834	μs	

\*1: The maximum value depends on the accuracy of built-in CR.

**Operation example of return from Low-Power consumption mode (by external interrupt\*1)**

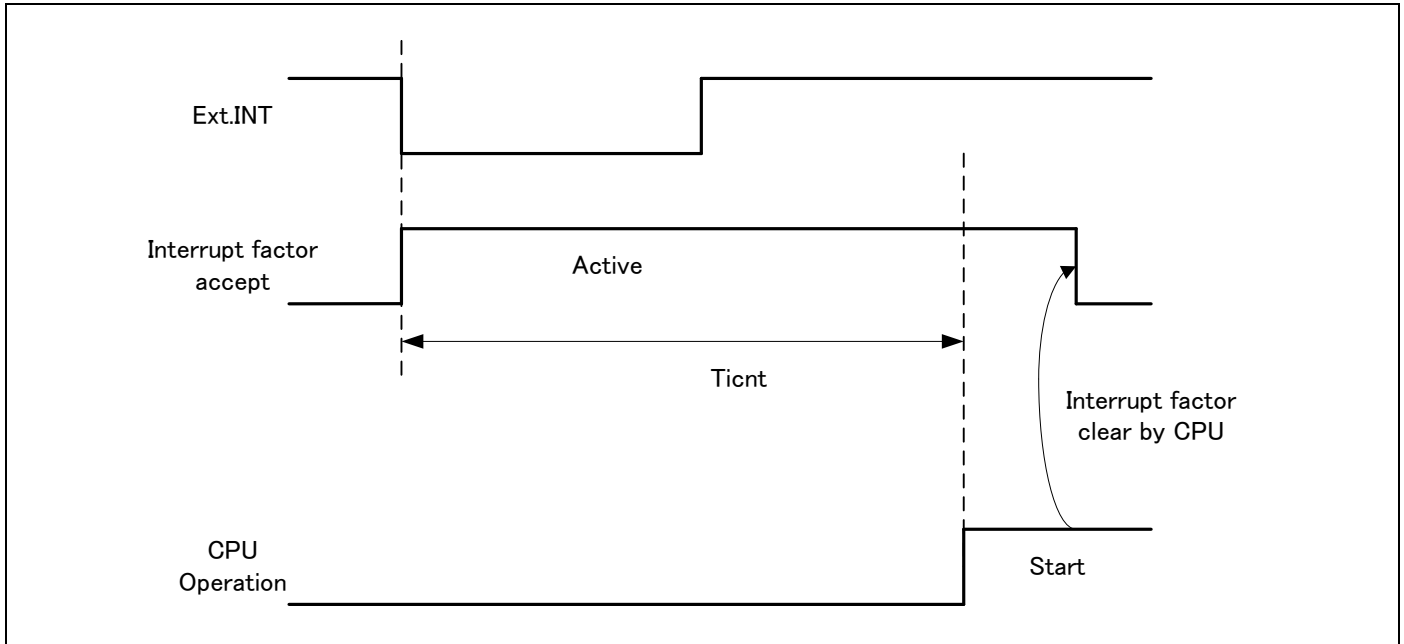

\*1: External interrupt is set to detecting fall edge.

Operation example of return from Low-Power consumption mode (by internal resource interrupt<sup>\*1</sup>)

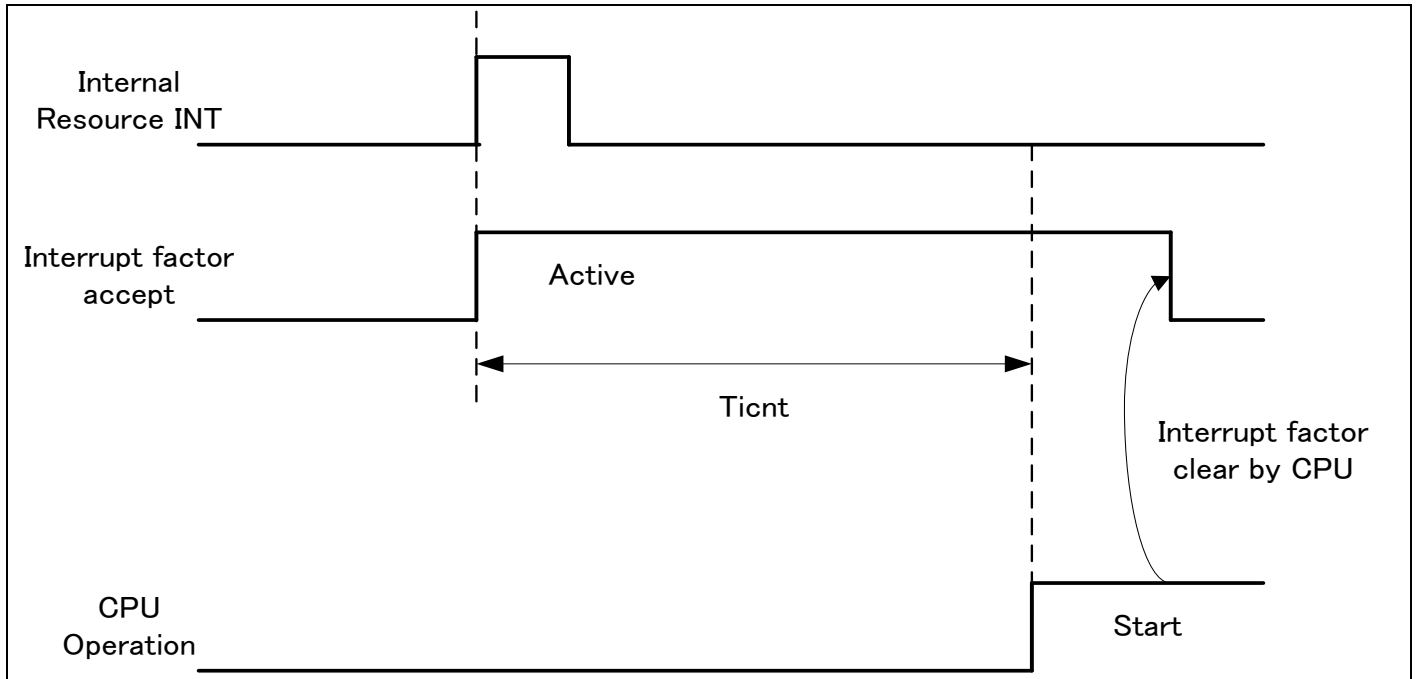

\*1: Internal resource interrupt is not included in return factor by the kind of Low-Power consumption mode.

**Notes:**

- The return factor is different in each Low-Power consumption modes.
- See "Chapter 6: Low Power Consumption Mode" and "Operations of Standby Modes" in FM3 Family Peripheral Manual about the return factor from Low-Power consumption mode.
- When interrupt recovers, the operation mode that CPU recovers depends on the state before the Low-Power consumption mode transition. See "Chapter 6: Low Power Consumption Mode" in "FM3 Family Peripheral Manual".

**12.10.2 Return Factor: Reset**

The return time from Low-Power consumption mode is indicated as follows. It is from releasing reset to starting the program operation.

**Return Count Time**

( $V_{CC} = 2.7V$  to  $5.5V$ ,  $T_A = -40^{\circ}C$  to  $+105^{\circ}C$ )

Parameter	Symbol	Value		Unit	Remarks
		Typ	Max <sup>*1</sup>		
SLEEP mode	Trcnt	365	554	$\mu s$	
High-speed CR TIMER mode, Main TIMER mode, PLL TIMER mode		365	554	$\mu s$	
Low-speed CR TIMER mode		555	934	$\mu s$	
Sub TIMER mode		608	976	$\mu s$	
STOP mode		475	774	$\mu s$	

\*1: The maximum value depends on the accuracy of built-in CR.

**Operation example of return from Low-Power consumption mode (by INITX)**

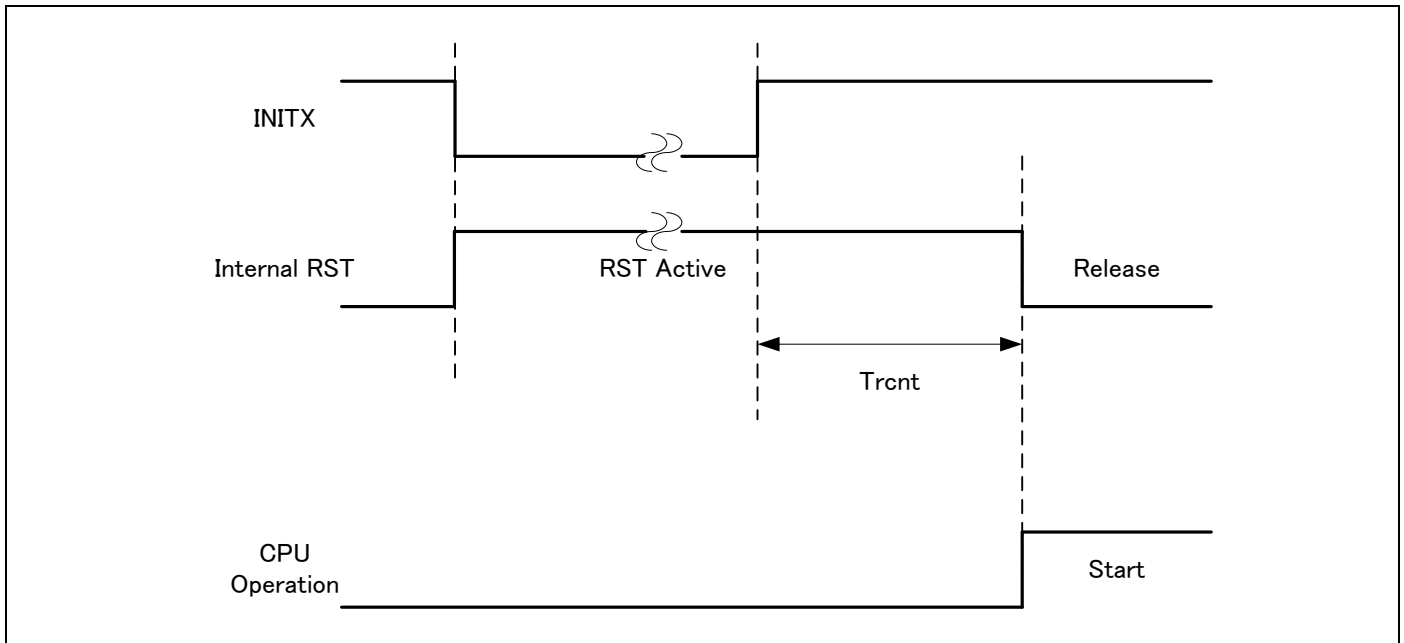

Operation example of return from low power consumption mode (by internal resource reset<sup>\*1</sup>)

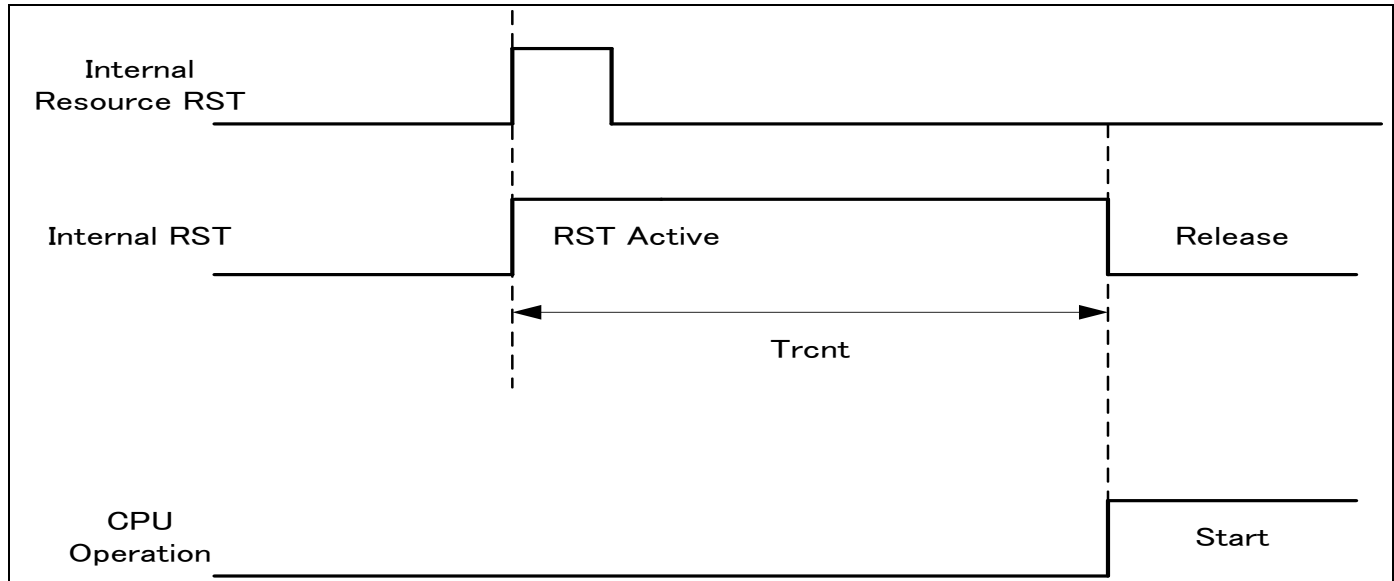

\*1: Internal resource reset is not included in return factor by the kind of Low-Power consumption mode.

**Notes:**

- The return factor is different in each Low-Power consumption modes. See "Chapter 6: Low Power Consumption Mode" and "Operations of Standby Modes" in FM3 Family Peripheral Manual.
- When interrupt recovers, the operation mode that CPU recovers depends on the state before the Low-Power consumption mode transition. See "Chapter 6: Low Power Consumption Mode" in "FM3 Family Peripheral Manual".
- The time during the power-on reset/low-voltage detection reset is excluded. See "(6) Power-on Reset Timing in 4. AC Characteristics in Electrical Characteristics" for the detail on the time during the power-on reset/low-voltage detection reset.
- When in recovery from reset, CPU changes to the high-speed CR run mode. When using the main clock or the PLL clock, it is necessary to add the main clock oscillation stabilization wait time or the main PLL clock stabilization wait time.
- The internal resource reset means the watchdog reset and the CSV reset.



**13. Ordering Information**

Part number	On-chip Flash memory	On-chip SRAM	Package	Packing
MB9AF311KPMC-G-JNE2	Main: 64 Kbyte Work: 32 Kbyte	16 Kbyte	Plastic LQFP 48-pin (0.5 mm pitch), (LQA048)	Tray
MB9AF312KPMC-G-JNE2	Main: 128 Kbyte Work: 32 Kbyte	16 Kbyte		
MB9AF311KPMC1-G-JNE2	Main: 64 Kbyte Work: 32 Kbyte	16 Kbyte	Plastic LQFP 52-pin (0.65 mm pitch), (LQC052 )	
MB9AF312KPMC1-G-JNE2	Main: 128 Kbyte Work: 32 Kbyte	16 Kbyte		
MB9AF311KQN-G-AVE2	Main: 64 Kbyte Work: 32 Kbyte	16 Kbyte	Plastic QFN 48-pin (0.5 mm pitch), (VNA048)	
MB9AF312KQN-G-AVE2	Main: 128 Kbyte Work: 32 Kbyte	16 Kbyte		

## 14. Package Dimensions

Package Type	Package Code
LQFP 48pin (0.5mm pitch)	LQA048

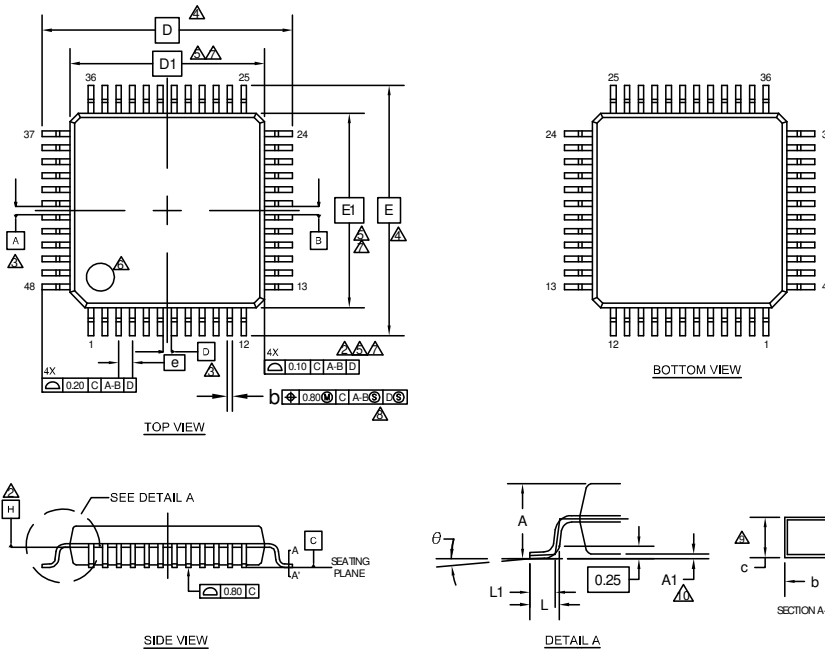

SYMBOL	DIMENSIONS		
	MIN.	NOM.	MAX.
A	—	—	1.70
A1	0.00	—	0.20
b	0.15	—	0.27
c	0.09	—	0.20
D	9.00 BSC		
D1	7.00 BSC		
e	0.50 BSC		
E	9.00 BSC		
E1	7.00 BSC		
L	0.45	0.60	0.75
L1	0.30	0.50	0.70
$\theta$	0°	—	8°

### NOTES

- ALL DIMENSIONS ARE IN MILLIMETERS.
  - DATUM PLANE H IS LOCATED AT THE BOTTOM OF THE MOLD PARTING LINE COINCIDENT WITH WHERE THE LEAD EXITS THE BODY.
  - DATUMS A-B AND D TO BE DETERMINED AT DATUM PLANE H.
  - TO BE DETERMINED AT SEATING PLANE C.
  - DIMENSIONS D1 AND E1 DO NOT INCLUDE MOLD PROTRUSION. ALLOWABLE PROTRUSION IS 0.25mm PRE SIDE. DIMENSIONS D1 AND E1 INCLUDE MOLD MISMATCH AND ARE DETERMINED AT DATUM PLANE H.
  - DETAILS OF PIN 1 IDENTIFIER ARE OPTIONAL BUT MUST BE LOCATED WITHIN THE ZONE INDICATED.
  - REGARDLESS OF THE RELATIVE SIZE OF THE UPPER AND LOWER BODY SECTIONS, DIMENSIONS D1 AND E1 ARE DETERMINED AT THE LARGEST FEATURE OF THE BODY EXCLUSIVE OF MOLD FLASH AND GATE BURRS. BUT INCLUDING ANY MISMATCH BETWEEN THE UPPER AND LOWER SECTIONS OF THE MOLDER BODY.
  - DIMENSION b DOES NOT INCLUDE DAMBAR PROTRUSION. THE DAMBAR PROTRUSION (S) SHALL NOT CAUSE THE LEAD WIDTH TO EXCEED b MAXIMUM BY MORE THAN 0.08mm. DAMBAR CANNOT BE LOCATED ON THE LOWER RADIUS OR THE LEAD FOOT.
  - THESE DIMENSIONS APPLY TO THE FLAT SECTION OF THE LEAD BETWEEN 0.10mm AND 0.25mm FROM THE LEAD TIP.
  - A1 IS DEFINED AS THE DISTANCE FROM THE SEATING PLANE TO THE LOWEST POINT OF THE PACKAGE BODY.

002-13731 \*\*

PACKAGE OUTLINE, 48 LEAD LQFP  
7.0X7.0X1.7 MM LQA048 REV\*\*

Package Type	Package Code
QFN 48pin (0.5mm pitch)	VNA048

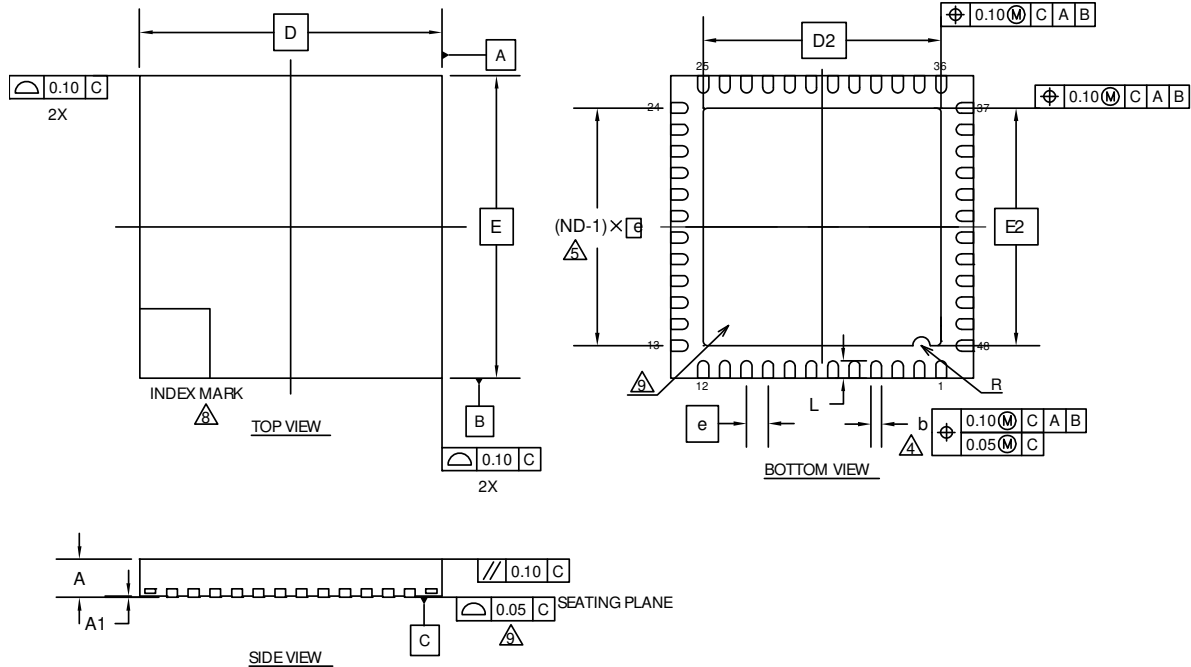

SYMBOL	DIMENSIONS		
	MIN.	NOM.	MAX.
A	—	—	0.90
A1	0.00	—	0.05
D	7.00 BSC		
E	7.00 BSC		
b	0.20	0.25	0.30
D2	5.50 BSC		
E2	5.50 BSC		
e	0.50 BSC		
R	0.20 REF		
L	0.35	0.40	0.45

**NOTE**

- ALL DIMENSIONS ARE IN MILLIMETERS
- DIMENSIONING AND TOLERANCING CONFORMS TO ASME Y14.5-1994
- N IS THE TOTAL NUMBER OF TERMINALS
- △ DIMENSION "b" APPLIES TO METALLIZED TERMINAL AND IS MEASURED BETWEEN 0.15 AND 0.30mm FROM TERMINAL TIP. IF THE TERMINAL HAS THE OPTIONAL RADIUS ON THE OTHER END OF THE TERMINAL THE DIMENSION "b" SHOULD NOT BE MEASURED IN THAT RADIUS AREA
- △ ND REFER TO THE NUMBER OF TERMINALS ON D OR E SIDE
- MAX. PACKAGE WARRPAGE IS 0.05mm.
- MAXIMUM ALLOWABLE BURRS IS 0.076mm IN ALL DIRECTIONS
- △ PIN #1 ID ON TOP WILL BE LOCATED WITHIN INDICATED ZONE
- △ BILATERAL COPLANARITY ZONE APPLIES TO THE EXPOSED HEAT SINK SLUG AS WELL AS THE TERMINALS
- JEDEC SPECIFICATION NO. REF: N/A

002-15528 \*\*

 PACKAGE OUTLINE: 48 LEAD QFN  
 7.0X7.0X0.9MM VNA048 5.5X6.5MM EPAD (SAWN) REV\*\*

Package Type	Package Code
LQFP 52pin (0.65mm pitch)	LQC052

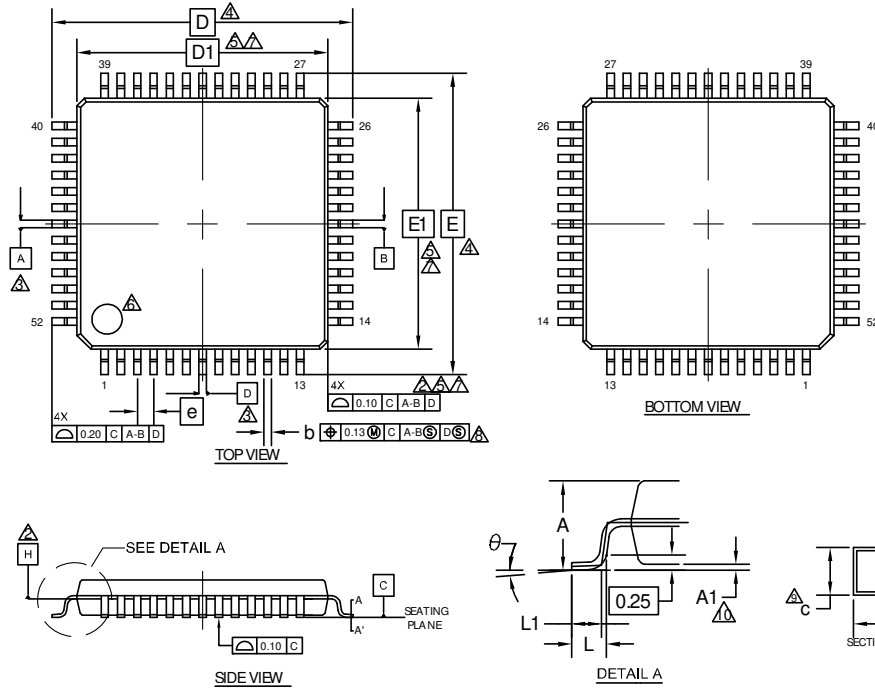

SYMBOL	DIMENSION		
	MIN.	NOM.	MAX.
A	—	—	1.70
A1	0.00	—	0.20
b	0.265	0.30	0.365
c	0.09	—	0.20
D	12.00 BSC		
D1	10.00 BSC		
e	0.65 BSC		
E	12.00 BSC		
E1	10.00 BSC		
L	0.45	0.60	0.75
L1	0.30	0.50	0.70
$\theta$	0°	—	8°

### NOTES

- ALL DIMENSIONS ARE IN MILLIMETERS.
- DATUM PLANE H IS LOCATED AT THE BOTTOM OF THE MOLD PARTING LINE COINCIDENT WITH WHERE THE LEAD EXITS THE BODY.
- DATUMS A-B AND D TO BE DETERMINED AT DATUM PLANE H.
- TO BE DETERMINED AT SEATING PLANE C.
- DIMENSIONS D1 AND E1 DO NOT INCLUDE MOLD PROTRUSION. ALLOWABLE PROTRUSION IS 0.25mm PRE SIDE. DIMENSIONS D1 AND E1 INCLUDE MOLD MISMATCH AND ARE DETERMINED AT DATUM PLANE H.
- DETAILS OF PIN 1 IDENTIFIER ARE OPTIONAL BUT MUST BE LOCATED WITHIN THE ZONE INDICATED.
- REGARDLESS OF THE RELATIVE SIZE OF THE UPPER AND LOWER BODY SECTIONS. DIMENSIONS D1 AND E1 ARE DETERMINED AT THE LARGEST FEATURE OF THE BODY EXCLUSIVE OF MOLD FLASH AND GATE BURRS. BUT INCLUDING ANY MISMATCH BETWEEN THE UPPER AND LOWER SECTIONS OF THE MOLDER BODY.
- DIMENSION b DOES NOT INCLUDE DAMBER PROTRUSION. THE DAMBAR PROTRUSION (S) SHALL NOT CAUSE THE LEAD WIDTH TO EXCEED b MAXIMUM BY MORE THAN 0.08mm. DAMBAR CANNOT BE LOCATED ON THE LOWER RADIUS OR THE LEAD FOOT.
- THESE DIMENSIONS APPLY TO THE FLAT SECTION OF THE LEAD BETWEEN 0.10mm AND 0.25mm FROM THE LEAD TIP.
- A1 IS DEFINED AS THE DISTANCE FROM THE SEATING PLANE TO THE LOWEST POINT OF THE PACKAGE BODY.

PACKAGE OUTLINE, 52 LEAD LQFP  
 10.0X10.0X1.7 MM LQC052 REV\*\*

002-13880 \*\*

## 15. Major Changes

Spanion Publication Number: DS706-00029

Page	Section	Change Results
Revision 1.0		
-	-	PRELIMINARY → Datasheet
7	Product lineup · function	Added the pin count.
8	Packages	Revised from "Planning".
23	I/O Circuit Type	Corrected the following description to "TypeB". Digital output → Digital input
34	Block Diagram	Corrected the following description. · AHB (Max 40MHz) → AHB (Max 42MHz) · APB0 (Max 40MHz) → APB0 (Max 42MHz) · APB1 (Max 40MHz) → APB1 (Max 42MHz) · APB2 (Max 40MHz) → APB2 (Max 42MHz)
45, 46	Electrical Characteristics 3. DC Characteristics (1) Current Rating	· Revised the value of "TBD". · Corrected the value. - "Power supply current (I <sub>CCR</sub> )" Typ: 60 → 50 - "Power supply current (I <sub>CCRD</sub> )" (RAM hold off) Typ: 45 → 30 - "Power supply current (I <sub>CCRD</sub> )" (RAM hold on) Typ: 48 → 33
61	(9) External Input Timing	Revised the value of "TBD".
66	5. 12-bit A/D Converter · Electrical characteristics for the A/D converter	· Deleted"(Preliminary value)". · Corrected the value of "Compare clock cycle". Max: 10000 → 2000
74	8. MainFlash Memory Write/Erase Characteristics Erase/write cycles and data hold time	Deleted"(targeted value)".
	9. WorkFlash Memory Write/Erase Characteristics Erase/write cycles and data hold time	
Revision 1.1		
-	-	Company name and layout design change
Revision 2.0		
2	Features USB Interface	Added the description of PLL for USB
25	I/O Circuit Type	Added the description of I <sup>2</sup> C to the type of E and F
25, 26	I/O Circuit Type	Added about +B input
32	Handling Devices	Added "Stabilizing power supply voltage"
32	Handling Devices Crystal oscillator circuit	Added the following description "Evaluate oscillation of your using crystal oscillator by your mount board."
33	Handling Devices C Pin	Changed the description
35	Block Diagram	Modified the block diagram
36	Memory Map · Memory map(1)	Modified the area of "External Device Area"
37	Memory Map · Memory map(2)	Added the summary of Flash memory sector and the note
44, 45	Electrical Characteristics 1. Absolute Maximum Ratings	· Added the Clamp maximum current · Added the output current of P80 and P81 · Added about +B input
46	Electrical Characteristics 2. Recommended Operation Conditions	· Modified the minimum value of Analog reference voltage · Added Smoothing capacitor · Added the note about less than the minimum power supply voltage
47-49	Electrical Characteristics 3. DC Characteristics (1) Current rating	· Changed the table format · Added Main TIMER mode current · Added Flash Memory Current · Moved A/D Converter Current

Page	Section	Change Results
52	Electrical Characteristics 4. AC Characteristics (1) Main Clock Input Characteristics	Added Master clock at Internal operating clock frequency
53	Electrical Characteristics 4. AC Characteristics (3) Built-in CR Oscillation Characteristics	Added Frequency stability time at Built-in high-speed CR
54	Electrical Characteristics 4. AC Characteristics (4-1) Operating Conditions of Main and USB PLL (4-2) Operating Conditions of Main PLL	<ul style="list-style-type: none"> <li>· Added Main PLL clock frequency</li> <li>· Added USB clock frequency</li> <li>· Added the figure of Main PLL connection and USB PLL connection</li> </ul>
55	Electrical Characteristics 4. AC Characteristics (6) Power-on Reset Timing	<ul style="list-style-type: none"> <li>· Added Time until releasing Power-on reset</li> <li>· Changed the figure of timing</li> </ul>
57-64	Electrical Characteristics 4. AC Characteristics (7) CSIO/UART Timing	<ul style="list-style-type: none"> <li>· Modified from UART Timing to CSIO/UART Timing</li> <li>· Changed from Internal shift clock operation to Master mode</li> <li>· Changed from External shift clock operation to Slave mode</li> </ul>
70	Electrical Characteristics 5. 12bit A/D Converter	<ul style="list-style-type: none"> <li>· Added the typical value of Integral Nonlinearity, Differential Nonlinearity, Zero transition voltage and Full-scale transition voltage</li> <li>· Added Conversion time at AVcc &lt; 4.5V</li> <li>· Modified Stage transition time to operation permission</li> <li>· Modified the minimum value of Reference voltage</li> </ul>
79-82	Electrical Characteristics 9. Return Time from Low-Power Consumption Mode	Added Return Time from Low-Power Consumption Mode
83	Ordering Information	Changed the description of part number

NOTE: Please see “Document History” about later revised information.

## Document History

Document Title: MB9A310K Series 32-bit ARM® Cortex®-M3, FM3 Microcontroller  
 Document Number: 002-05625

Revision	ECN	Orig. of Change	Submission Date	Description of Change
**	-	TOYO	02/20/2015	Migrated to Cypress and assigned document number 002-05625. No change to document contents or format.
*A	5232740	TOYO	04/21/2016	Updated to Cypress format.
*B	5561750	YSKA	03/22/2017	<p>Corrected "USB Function" to "USB Device" in the following chapters.            Features  <a href="#">1. Product Lineup</a>  <a href="#">4. List of Pin Functions</a></p> <p>Changed an explanation from "from 01 to 99" to "from 00 to 99" in Real-Time Clock (RTC) (Page 3) of Features, and Deleted "Second/A day of the week" of interrupt function.</p> <p>Changed package code as the following in chapter :</p> <p><a href="#">2. Packages</a>  <a href="#">3. Pin Assignment</a>  <a href="#">13. Ordering Information</a>  <a href="#">14. Package Dimensions.</a></p> <p>FTP-48P-M49 -&gt; LQA048, LCC-48P-M73 -&gt; VNA048,            FPT-52P-M02 -&gt; LQC052</p> <p>Corrected "J-TAG" to "JTAG" in <a href="#">4. List of Pin Functions</a>.            Added Note for JTAG pin in <a href="#">4. List of Pin Functions</a>.</p> <p>Changed remark [1] to "When all ports are input and are fixed at "0"." in <a href="#">12.3.1 Current Rating</a>.</p> <p>Changed Parameter "Power supply rising time (<math>t_{VCCR}</math>)" to "Power ramp rate (dV/dt)" in <a href="#">12.4.7 Power-on Reset Timing</a>, Changed the minimum to 0.7mV/μs, Changed the maximum to 1000mV/μs, and Added remarks and note.</p> <p>Corrected "Analog port input current" to "Analog port input leak current" in <a href="#">12.5 12-bit A/D Converter</a>.</p> <p>Added the Baud rate spec in "12.4.9 CSIO/UART Timing"(<a href="#">Page 54, 56, 58, 60</a>)</p>

## Sales, Solutions, and Legal Information

### Worldwide Sales and Design Support

Cypress maintains a worldwide network of offices, solution centers, manufacturer's representatives, and distributors. To find the office closest to you, visit us at [Cypress Locations](#).

#### Products

ARM® Cortex® Microcontrollers	<a href="http://cypress.com/arm">cypress.com/arm</a>
Automotive	<a href="http://cypress.com/automotive">cypress.com/automotive</a>
Clocks & Buffers	<a href="http://cypress.com/clocks">cypress.com/clocks</a>
Interface	<a href="http://cypress.com/interface">cypress.com/interface</a>
Internet of Things	<a href="http://cypress.com/iot">cypress.com/iot</a>
Memory	<a href="http://cypress.com/memory">cypress.com/memory</a>
Microcontrollers	<a href="http://cypress.com/mcu">cypress.com/mcu</a>
PSoC	<a href="http://cypress.com/psoc">cypress.com/psoc</a>
Power Management ICs	<a href="http://cypress.com/pmic">cypress.com/pmic</a>
Touch Sensing	<a href="http://cypress.com/touch">cypress.com/touch</a>
USB Controllers	<a href="http://cypress.com/usb">cypress.com/usb</a>
Wireless/RF	<a href="http://cypress.com/wireless">cypress.com/wireless</a>

#### PSoC® Solutions

[PSoC 1](#) | [PSoC 3](#) | [PSoC 4](#) | [PSoC 5LP](#)

#### Cypress Developer Community

[Forums](#) | [WICED IOT Forums](#) | [Projects](#) | [Video](#) | [Blogs](#) | [Training](#) | [Components](#)

#### Technical Support

[cypress.com/support](http://cypress.com/support)

ARM and Cortex are the registered trademarks of ARM Limited in the EU and other countries.

All other trademarks or registered trademarks referenced herein are the property of their respective owners.

© Cypress Semiconductor Corporation, 2012-2017. This document is the property of Cypress Semiconductor Corporation and its subsidiaries, including Spansion LLC ("Cypress"). This document, including any software or firmware included or referenced in this document ("Software"), is owned by Cypress under the intellectual property laws and treaties of the United States and other countries worldwide. Cypress reserves all rights under such laws and treaties and does not, except as specifically stated in this paragraph, grant any license under its patents, copyrights, trademarks, or other intellectual property rights. If the Software is not accompanied by a license agreement and you do not otherwise have a written agreement with Cypress governing the use of the Software, then Cypress hereby grants you a personal, non-exclusive, nontransferable license (without the right to sublicense) (1) under its copyright rights in the Software (a) for Software provided in source code form, to modify and reproduce the Software solely for use with Cypress hardware products, only internally within your organization, and (b) to distribute the Software in binary code form externally to end users (either directly or indirectly through resellers and distributors), solely for use on Cypress hardware product units, and (2) under those claims of Cypress's patents that are infringed by the Software (as provided by Cypress, unmodified) to make, use, distribute, and import the Software solely for use with Cypress hardware products. Any other use, reproduction, modification, translation, or compilation of the Software is prohibited.

TO THE EXTENT PERMITTED BY APPLICABLE LAW, CYPRESS MAKES NO WARRANTY OF ANY KIND, EXPRESS OR IMPLIED, WITH REGARD TO THIS DOCUMENT OR ANY SOFTWARE OR ACCOMPANYING HARDWARE, INCLUDING, BUT NOT LIMITED TO, THE IMPLIED WARRANTIES OF MERCHANTABILITY AND FITNESS FOR A PARTICULAR PURPOSE. To the extent permitted by applicable law, Cypress reserves the right to make changes to this document without further notice. Cypress does not assume any liability arising out of the application or use of any product or circuit described in this document. Any information provided in this document, including any sample design information or programming code, is provided only for reference purposes. It is the responsibility of the user of this document to properly design, program, and test the functionality and safety of any application made of this information and any resulting product. Cypress products are not designed, intended, or authorized for use as critical components in systems designed or intended for the operation of weapons, weapons systems, nuclear installations, life-support devices or systems, other medical devices or systems (including resuscitation equipment and surgical implants), pollution control or hazardous substances management, or other uses where the failure of the device or system could cause personal injury, death, or property damage ("Unintended Uses"). A critical component is any component of a device or system whose failure to perform can be reasonably expected to cause the failure of the device or system, or to affect its safety or effectiveness. Cypress is not liable, in whole or in part, and you shall and hereby do release Cypress from any claim, damage, or other liability arising from or related to all Unintended Uses of Cypress products. You shall indemnify and hold Cypress harmless from and against all claims, costs, damages, and other liabilities, including claims for personal injury or death, arising from or related to any Unintended Uses of Cypress products.

Cypress, the Cypress logo, Spansion, the Spansion logo, and combinations thereof, WICED, PSOC, CapSense, EZ-USB, F-RAM, and Traveo are trademarks or registered trademarks of Cypress in the United States and other countries. For a more complete list of Cypress trademarks, visit [cypress.com](http://cypress.com). Other names and brands may be claimed as property of their respective owners.