

Linear Single Cell Li-Ion Battery Charger IC

General Description

The RT9505 is a fully integrated low cost single-cell Li-Ion battery charger IC ideal for portable applications. The RT9505 is capable of being powered up from AC adapter. The RT9505 enters sleep mode when AC adapter is removed.

The RT9505 optimizes the charging task by using a control algorithm including preconditioning mode, fast charge mode and constant voltage mode. The charging task is terminated as the charge current drops below the preset threshold. The AC adapter charge current can be programmed up to 1A with an external resistor. The internal thermal feedback circuitry regulates the die temperature to optimize the charge rate for all ambient temperatures.

The RT9505 features 18V maximum rating voltages for AC adapter. The other features are under voltage protection, over voltage protection for AC adapter supply and battery temperature monitoring.

Ordering Information

- RT9505 □ □
- Package Type
QW : WDFN-10L 3x3 (W-Type)
 - Lead Plating System
P : Pb Free
G : Green (Halogen Free and Pb Free)

Note :

Richtek products are :

- ▶ RoHS compliant and compatible with the current requirements of IPC/JEDEC J-STD-020.
- ▶ Suitable for use in SnPb or Pb-free soldering processes.

Features

- 18V Maximum Rating for AC Adapter
- Internal Integrate P-MOSFETS
- AC Adapter Power Good Status Indicator
- Charge Status Indicator
- Under Voltage Protection
- Over Voltage Protection
- Automatic Recharge Feature
- Battery Temperature Monitoring
- Small 10-Lead WDFN Package
- Thermal Feedback Optimizing Charge Rate
- RoHS Compliant and 100% Lead (Pb)-Free

Applications

- Digital Cameras
- Cellular Phones
- Personal Data Assistants (PDAs)
- MP3 Players
- Hand Held PCs

Pin Configurations

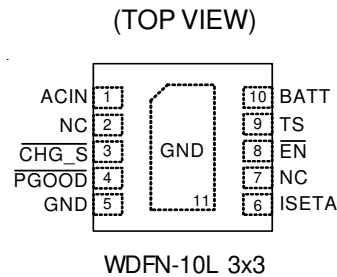

Marking Information

For marking information, contact our sales representative directly or through a Richtek distributor located in your area.

Typical Application Circuit

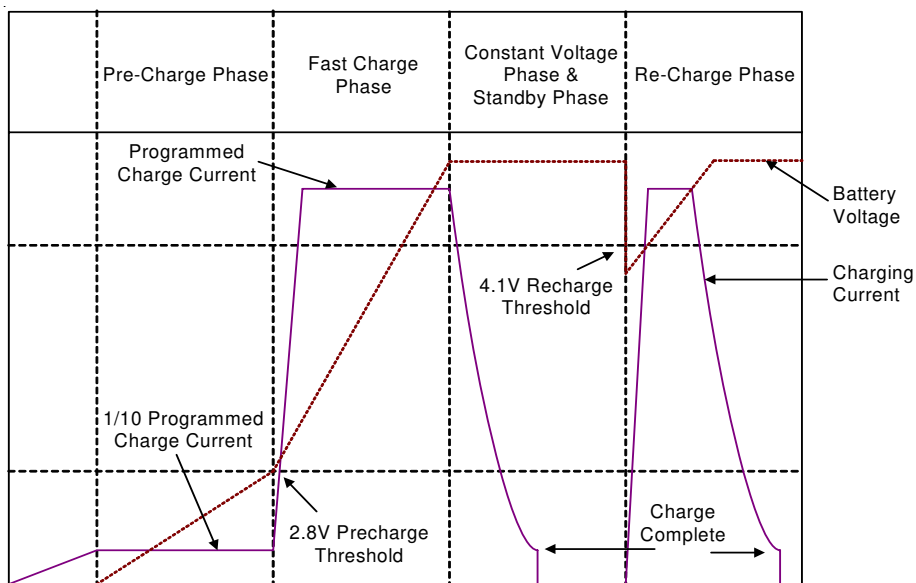
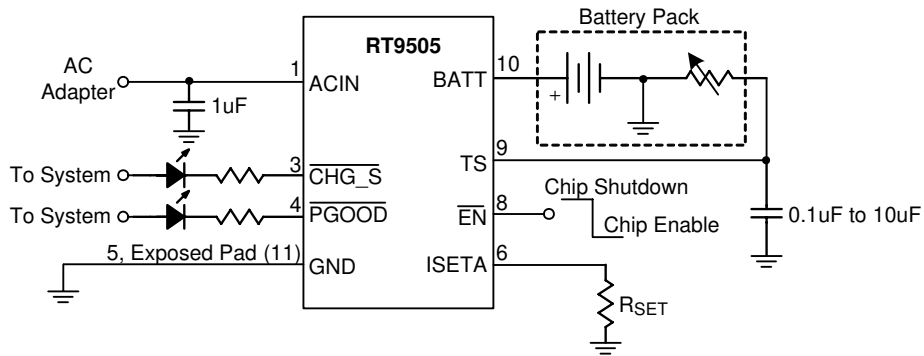

Functional Pin Description

Pin No.	Pin Name	Pin Function
1	ACIN	Wall Adaptor Charge Input Supply.
2, 7	NC	No Internal Connection.
3	$\overline{\text{CHG_S}}$	Charge Status Indicator Output (open drain).
4	$\overline{\text{PGOOD}}$	Power Good Indicator Output (open drain).
5	GND	Ground.
6	ISETA	Wall Adaptor Supply Charge Current Set Point.
8	$\overline{\text{EN}}$	Charge Enable Input (active low).
9	TS	Temperature Sense Input.
10	BATT	Battery Charge Current Output.
11 (Exposed Pad)	GND	Exposed pad should be soldered to PCB board and connected to GND.

Function Block Diagram

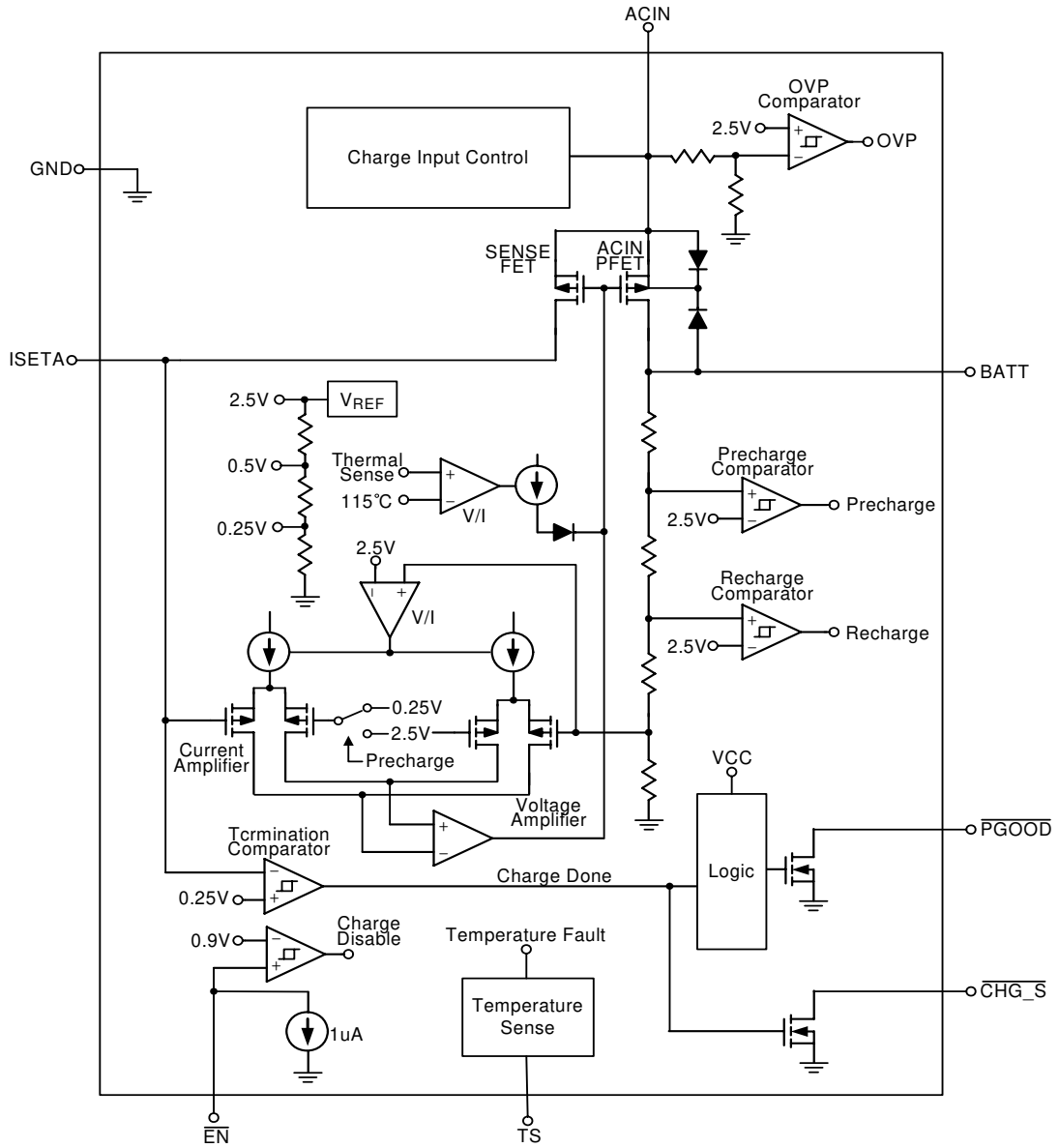

Table

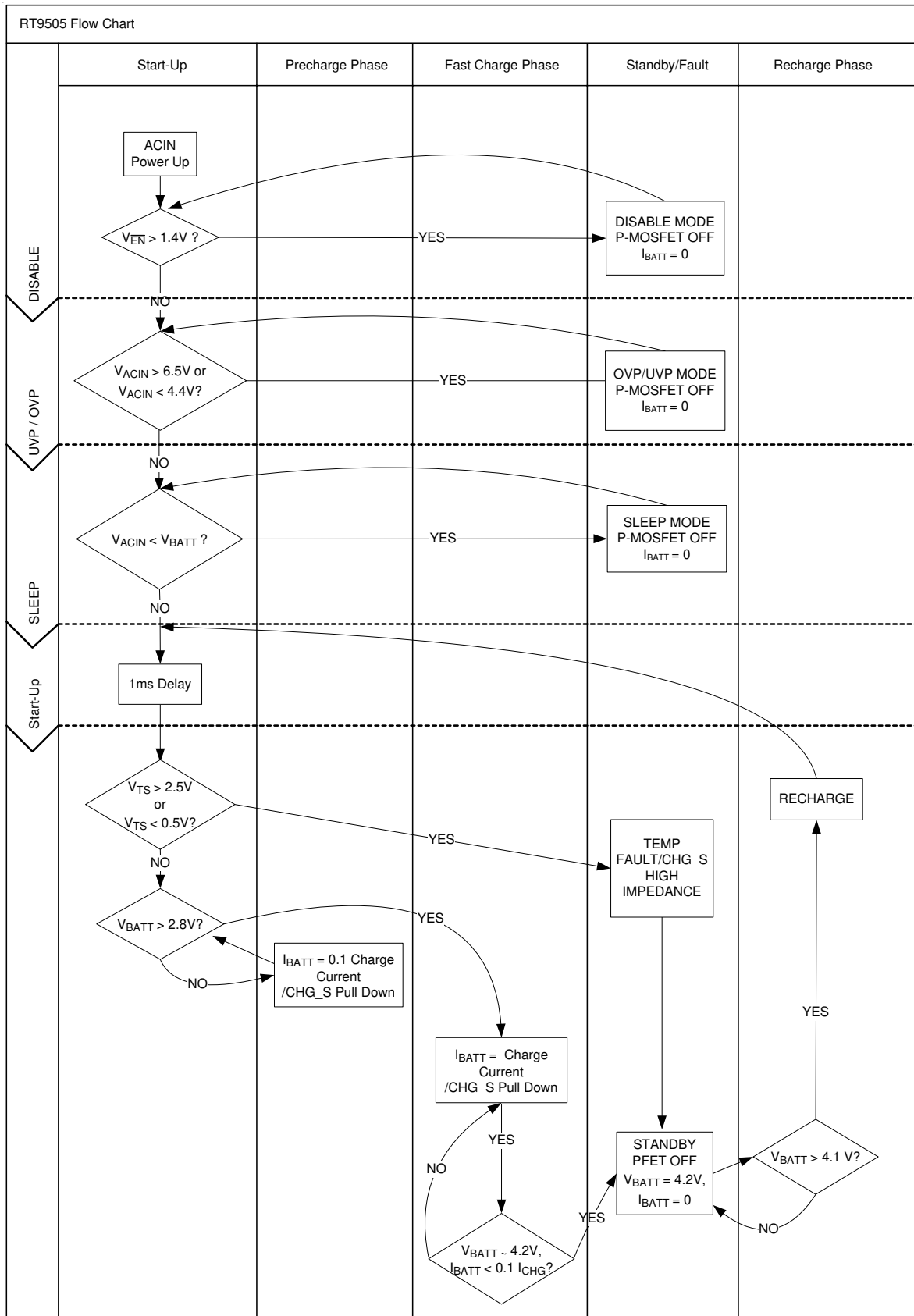

Absolute Maximum Ratings (Note 1)

- ACIN Input Voltage ----- -0.3V to 18V
- \overline{EN} Input Voltage ----- -0.3V to 6V
- Output Current ----- 1.2A
- Power Dissipation, P_D @ $T_A = 25^\circ\text{C}$
- WDFN-10L 3x3 ----- 0.926W
- Package Thermal Resistance (Note 2)
- WDFN-10L 3x3, θ_{JA} ----- 108°C/W
- WDFN-10L 3x3, θ_{JC} ----- 8.2°C/W
- Lead Temperature (Soldering, 10 sec.) ----- 260°C
- Junction Temperature ----- 150°C
- Storage Temperature Range ----- -65°C to 150°C
- ESD Susceptibility (Note 3)
- HBM (Human Body Mode) ----- 2kV
- MM (Machine Mode) ----- 200V

Recommended Operating Conditions (Note 4)

- ACIN Input Voltage Range ----- 4.5V to 6V
- Junction Temperature Range ----- -40°C to 125°C
- Ambient Temperature Range ----- -40°C to 85°C

Electrical Characteristics

(ACIN = 5V, $T_A = 27^\circ\text{C}$, Unless Otherwise specification)

Parameter	Symbol	Test Conditions	Min	Typ	Max	Units
Supply Input						
ACIN UVP Rising Threshold Voltage	V_{UV_HIGH}		--	4.4	4.5	V
ACIN UVP Hysteresis	V_{UV_LOW}		50	80	120	mV
ACIN Standby Current	I_{STBY}	$V_{BATT} = 4.5V$	--	300	500	uA
ACIN Shutdown Current	I_{SHDN}	$\overline{V_{EN}} = HIGH$	--	50	100	uA
ACIN UVP Current	I_{UVP}	$V_{ACIN} = 4V, V_{USB} = 4V,$ $V_{BATT} = 3V$	--	150	250	uA
BATT Sleep Leakage Current	I_{SLEEP}	$V_{ACIN} = 4V, V_{USB} = 4V,$ $V_{BATT} = 4.5V$	--	2	5	uA
Voltage Regulation						
BATT Regulation Voltage	V_{REG}	$I_{BATT} = 60mA$	4.158	4.2	4.242	V
Regulation Voltage Accuracy			-1	--	+1	%
ACIN MOSFET	$R_{DS(ON)_ACIN}$	$I_{BATT} = 500mA$	--	600	--	mΩ
Current Regulation						
ISETA Set Voltage (Fast Charge Phase)	V_{ISETA}	$V_{BATT} = 3.5V$	2.45	2.5	2.55	V
Full Charge Setting Range	I_{CHG_AC}		100	--	1200	mA
ACIN Charge Current accuracy	I_{CHG_AC}	$V_{BATT} = 3.8V,$ $R_{ISET} = 1.5k\Omega$	--	500	--	mA

To be continued

Parameter	Symbol	Test Conditions	Min	Typ	Max	Units	
Precharge							
BATT Pre-Charge Rising Threshold	V_{PRECH}		2.6	2.8	3	V	
BATT Pre-Charge Threshold Hysteresis	ΔV_{PRECH}		50	100	200	mV	
Pre-Charge Current	I_{PCHG}	$V_{BATT} = 2V$	8	10	12	%	
Recharge Threshold							
BATT Re-Charge Falling Threshold Hysteresis	ΔV_{RECH_L}	$V_{REG} - V_{BATT}$	60	100	150	mV	
Charge Termination Detection							
ISETA Charge Termination Set Voltage	V_{TERM}	$V_{BATT} = 4.2V$	225	250	275	mV	
Termination Current Ratio (default)	I_{TERM}	$V_{BATT} = 4.2V$	--	10	--	%	
Logic Input/Output							
$\overline{CHG_S}$ Pull Down Voltage	$V_{\overline{CHG_S}}$	TBD, $I_{\overline{CHG_S}} = 5mA$	--	65	--	mV	
\overline{PGOOD} Pull Down Voltage	$V_{\overline{PGOOD}}$	TBD, $I_{\overline{PGOOD}} = 5mA$	--	220	--	mV	
\overline{EN} Threshold	Logic-High Voltage	V_{IH}	1.5	--	--	V	
	Logic-Low Voltage	V_{IL}	--	--	0.4	V	
\overline{EN} Pin Input Current	$I_{\overline{EN}}$	$V_{\overline{EN}} = 2V$	--	--	2	μA	
Battery Temperature Sense							
TS Pin Source Current	I_{TS}	$V_{TS} = 1.5V$	96	102	108	μA	
TS Pin Threshold	Low Voltage	V_{TS_LOW}	Falling	0.485	0.5	0.515	V
	High Voltage	V_{TS_HIGH}	Rising	2.45	2.5	2.55	V
Protection							
Thermal Regulation			--	125	--	$^{\circ}C$	
OVP SET		Internal Default	--	6.5	--	V	

Note 1. Stresses listed as the above "Absolute Maximum Ratings" may cause permanent damage to the device. These are for stress ratings. Functional operation of the device at these or any other conditions beyond those indicated in the operational sections of the specifications is not implied. Exposure to absolute maximum rating conditions for extended periods may remain possibility to affect device reliability.

Note 2. θ_{JA} is measured in the natural convection at $T_A = 25^{\circ}C$ on a high effective thermal conductivity test board (4 layers, 1S) of JEDEC 51-7 thermal measurement standard. The case point of θ_{JC} is on the expose pad for the package.

Note 3. Devices are ESD sensitive. Handling precaution is recommended.

Note 4. The device is not guaranteed to function outside its operating conditions.

Typical Operating Characteristics

ACIN Power On

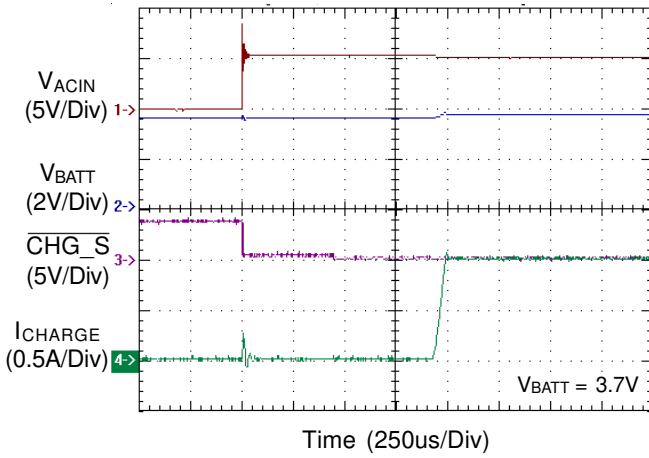

ACIN Power Off

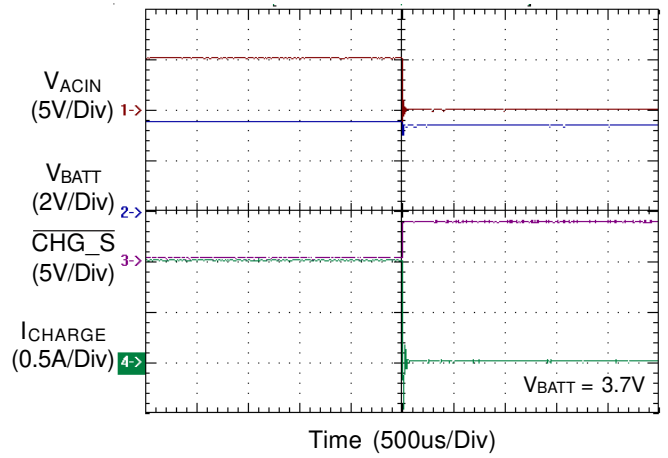

ACIN OVP

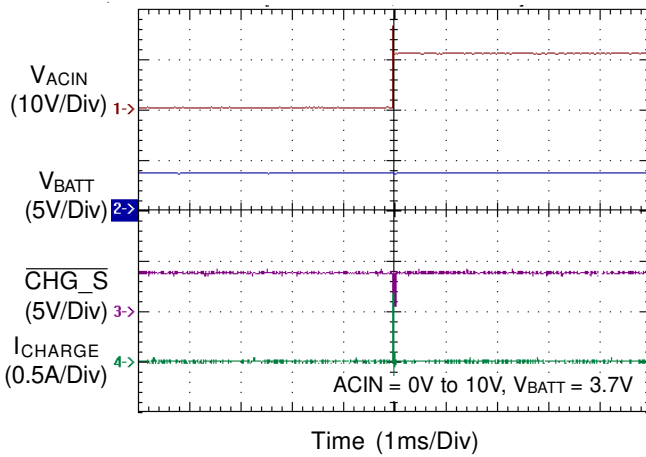

ACIN OVP

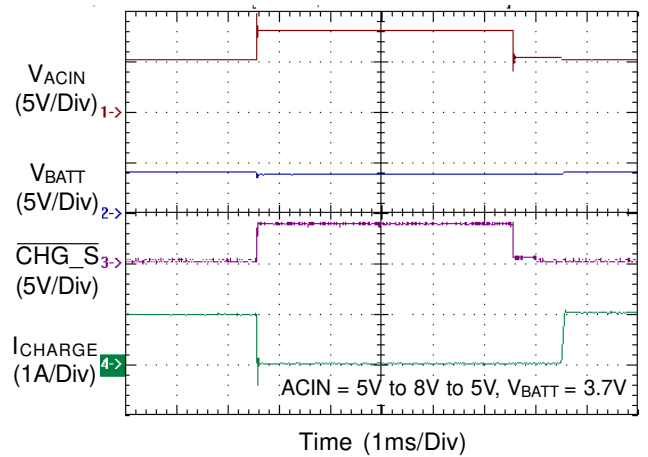

Input Voltage Transition

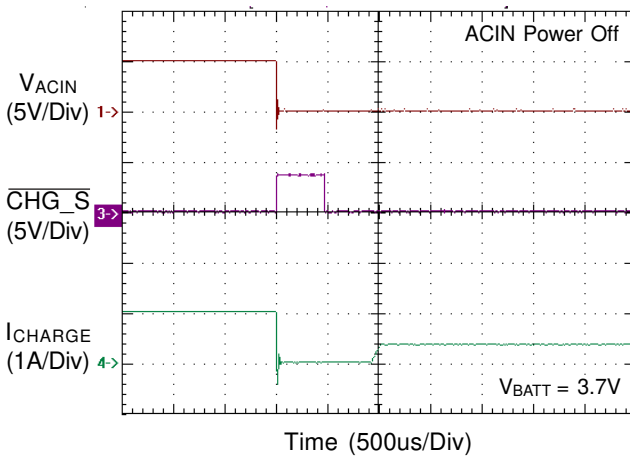

Input Voltage Transition

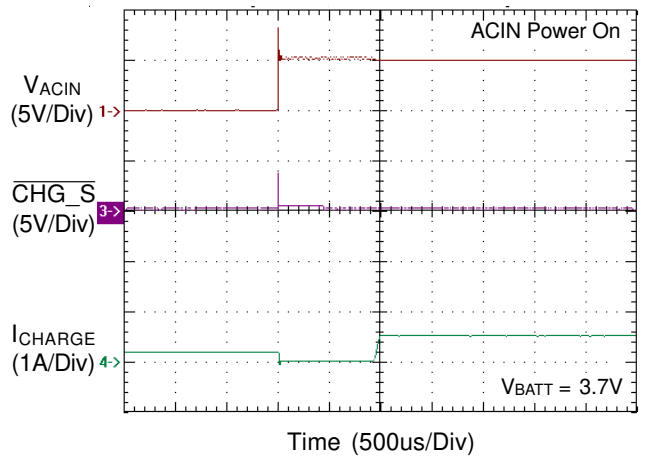

Application Information

Automatically Power Source Selection

The RT9505 is a battery charger IC which is designed for Li-ion Battery with 4.2V rated voltage.

ACIN Mode : When the ACIN input voltage is higher than the UVP voltage level (4.4V), the RT9505 will turn on ACIN P-MOSFET.

Sleep Mode : The RT9505 will enter Sleep Mode when ACIN input voltage are removed. This feature provides low leakage current from the battery during the absence of input supply.

ACIN Over Voltage Protection

The ACIN input voltage is monitored by an internal OVP comparator. The comparator has an accurate reference of 2.5V from the band-gap reference. The OVP threshold is set by the internal resistive. The protection threshold is set to 6.5V. When the input voltage exceeds the threshold, the comparator outputs a logic signal to turn off the power P-MOSFET to prevent the high input voltage from damaging the electronics in the handheld system. When the input over oltage condition is removed (ACIN < 6V), the comparator re-enables the output by running through the soft-start.

Battery Temperature Monitoring

The RT9505 continuously monitors battery temperature by measuring the voltage between the TS and GND pins. The RT9505 has an internal current source to provide the bias for the most common 10kΩ negative-temperature coefficient thermal resistor (NTC) (see Figure 1). The RT9505 compares the voltage on the TS pin against the internal VTS_HIGH and VTS_LOW thresholds to determine if charging is allowed.

When the temperature outside the VTS_HIGH and VTS_LOW thresholds is detected, the device will immediately stop the charge. The RT9505 stops charge and keep monitoring the battery temperature when the temperature sense input voltage is back to the threshold between VTS_HIGH and VTS_LOW, the charger will be resumed. Charge is resumed when the temperature returns to the normal range. However the user may modify thresholds by the negative-temperature coefficient thermal

resistor or adding two external resistors. (see Figure 2.)

The capacitor should be placed close to TS(Pin 9) and connected to the ground plane. The capacitance value (0.1uF to 10uF) should be selected according to the quality of PCB layout. It is recommended to use 10uF if the layout is poor if prevent noise.

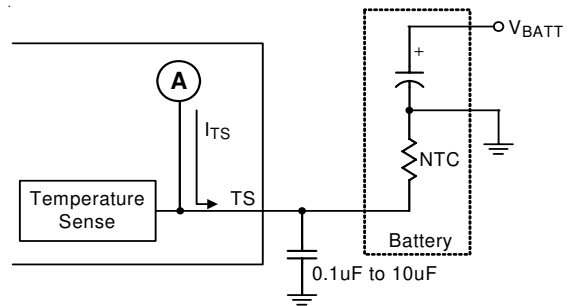

$$V_{TS} = I_{TS} \times R_{NTC}$$

Turn off when $V_{TS} \geq 2.5V$ or $V_{TS} \leq 0.5V$

Figure 1. Temperature Sensing Configuration

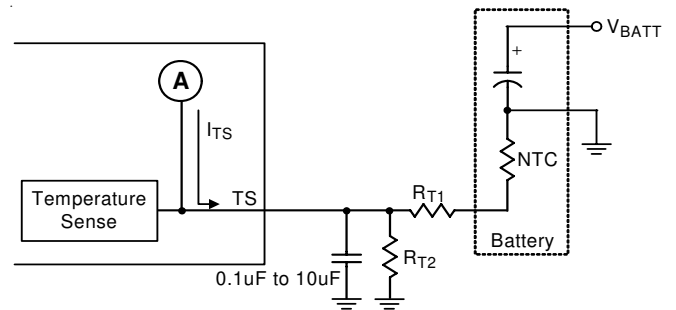

$$V_{TS} = I_{TS} \frac{R_{T2} \times (R_{T1} + R_{NTC})}{R_{T1} + R_{T2} + R_{NTC}}$$

Turn off when $V_{TS} \geq 2.5V$ or $V_{TS} \leq 0.5V$

Figure 2. Temperature Sensing Circuit

Fast-Charge Current Setting

The RT9505 offers ISETA pin to determine the ACIN charge rate from 100mA to 1.2A. The charge current can be calculated as following equation.

$$I_{charge_ac} = K_{SET} \frac{V_{SET}}{R_{SETA}}$$

The parameter $K_{SET} = 300$; $V_{SET} = 2.5V$. R_{SETA} is the resistor connected between the ISETA and GND.

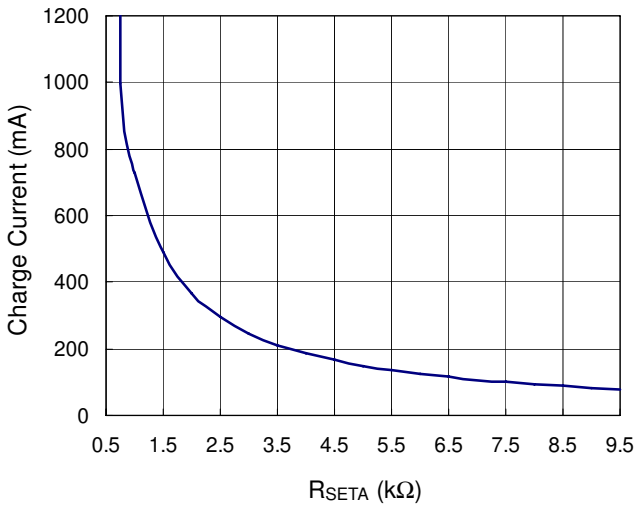

Figure 3. ACIN Mode Charge Current Setting

Pre- Charge Current Setting

During a charge cycle if the battery voltage is below the VPRECH threshold, the RT9505 applies a pre-charge mode to the battery. This feature revives deeply discharged cells and protects battery life. The RT9505 internal determines the pre-charge rate as 10% of the fast-charge current.

Battery Voltage Regulation

The RT9505 monitors the battery voltage through the BATT pin. Once the battery voltage level closes to the VREG threshold, the RT9505 voltage enters constant phase and the charging current begins to taper down. When battery voltage is over the VREG threshold, the RT9505 will stop charge and keep to monitor the battery voltage. However, when the battery voltage decreases 100mV below the V_{REG}, it will be recharged to keep the battery voltage.

Charge Status Outputs

The open-drain $\overline{CHG_S}$ and \overline{PGOOD} outputs indicate various charger operations as shown in the following table. These status pins can be used to drive LEDs or communicate to the host processor. Note that ON indicates the open-drain transistor is turned on and LED is bright.

Charge State		$\overline{CHG_S}$	\overline{PGOOD}
ACIN	Charge	ON	ON
	Charge done	OFF	ON

Temperature Regulation and Thermal Protection

In order to maximize the charge rate, the RT9505 features a junction temperature regulation loop. If the power dissipation of the IC results in a junction temperature greater than the thermal regulation threshold (125°C), the RT9505 throttles back on the charge current in order to maintain a junction temperature around the thermal regulation threshold (125°C). The RT9505 monitors the junction temperature, T_J, of the die and disconnects the battery from the input if T_J exceeds 125°C. This operation continues until junction temperature falls below thermal regulation threshold (125°C) by the hysteresis level. This feature prevents the chip from damage.

Selecting the Input and Output Capacitors

In most applications, the most important is the high-frequency decoupling capacitor on the input of the RT9505. A 1uF ceramic capacitor, placed in close proximity to input pin and GND pin is recommended. In some applications depending on the power supply characteristics and cable length, it may be necessary to add an additional 10uF ceramic capacitor to the input. The RT9505 requires a small output capacitor for loop stability. A 1uF ceramic capacitor placed between the BATT pin and GND is typically sufficient.

Layout Consideration

The RT9505 is a fully integrated low cost single-cell Li-Ion battery charger ideal for portable applications. Careful PCB layout is necessary. For best performance, place all peripheral components as close to the IC as possible. A short connection is highly recommended. The following guidelines should be strictly followed when designing a PCB layout for the RT9505.

- ▶ Input capacitor should be placed close to IC and connected to ground plane. The trace of input in the PCB should be placed far away the sensitive devices or shielded by the ground.

- ▶ The GND should be connected to a strong ground plane for heat sinking and noise protection.
- ▶ The connection of R_{SETA} should be isolated from other noisy traces. The short wire is recommended to prevent EMI and noise coupling.
- ▶ Output capacitor should be placed close to IC and connected to ground plane to reduce noise coupling.
- ▶ The TS's capacitor should be placed close to TS (Pin 9) and connected to ground plane. The capacitance (0.1uF to 10uF) base on PCB layout. When PCB has poor layout, the 10uF is recommended to prevent noise.

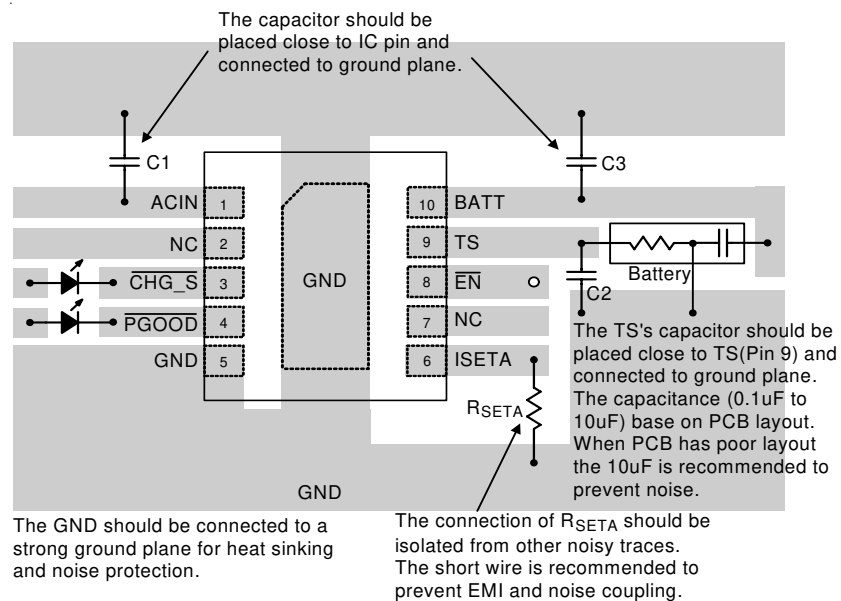
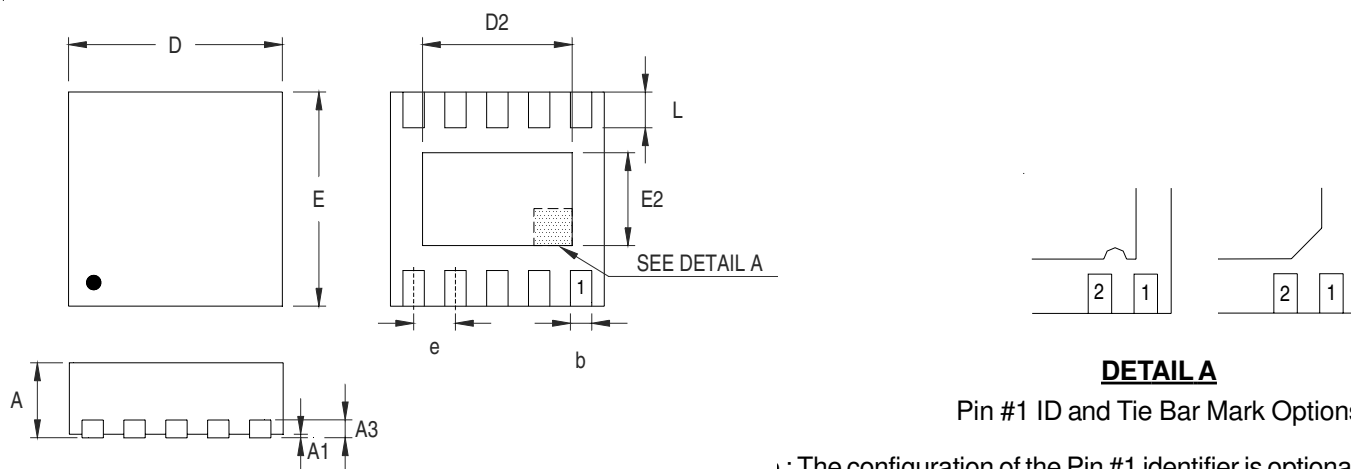

Figure 4

Outline Dimension



DETAIL A

Pin #1 ID and Tie Bar Mark Options

: The configuration of the Pin #1 identifier is optional, but must be located within the zone indicated.

Symbol	Dimensions In Millimeters		Dimensions In Inches	
	Min	Max	Min	Max
A	0.700	0.800	0.028	0.031
A1	0.000	0.050	0.000	0.002
A3	0.175	0.250	0.007	0.010
b	0.180	0.300	0.007	0.012
D	2.950	3.050	0.116	0.120
D2	2.300	2.650	0.091	0.104
E	2.950	3.050	0.116	0.120
E2	1.500	1.750	0.059	0.069
e	0.500		0.020	
L	0.350	0.450	0.014	0.018

W-Type 10L DFN 3x3 Package

Richtek Technology Corporation

Headquarter
5F, No. 20, Taiyuen Street, Chupei City
Hsinchu, Taiwan, R.O.C.
Tel: (8863)5526789 Fax: (8863)5526611

Richtek Technology Corporation

Taipei Office (Marketing)
5F, No. 95, Minchiuan Road, Hsintien City
Taipei County, Taiwan, R.O.C.
Tel: (8862)86672399 Fax: (8862)86672377
Email: marketing@richtek.com

Information that is provided by Richtek Technology Corporation is believed to be accurate and reliable. Richtek reserves the right to make any change in circuit design, specification or other related things if necessary without notice at any time. No third party intellectual property infringement of the applications should be guaranteed by users when integrating Richtek products into any application. No legal responsibility for any said applications is assumed by Richtek.