

- 1 POLYESTER,PBT,BLACK,PER MIL-M-24519
- 2 POLYESTER,PBT,NATURAL,PER MIL-M-24519
- 3 ZINC PER QQ-Z-363
- 4 PHOSPHOR BRONZE PER QQ-B-750
- 5 TIN-LEAD PLATE PER ASTM-B-545
- 6 GOLD PL PER MIL-G-45204
- 7 RESISTOR CHARACTERISTICS:
 - A. OHMS (SEE TABLE)
 - B. 5% TOLERANCE
 - C. 400mW POWER RATING
- 8 SELECTIVELY GOLD PLATED ON INTERFACE AREA PER: MIL-G-45204, .000030 THK,TIN PLATE ON SOLDER TAIL PER: ASTM-B-545, ALL OVER NICKEL PL PER: QQ-N-290
- 9. BOARD THICKNESS: .062 MAX

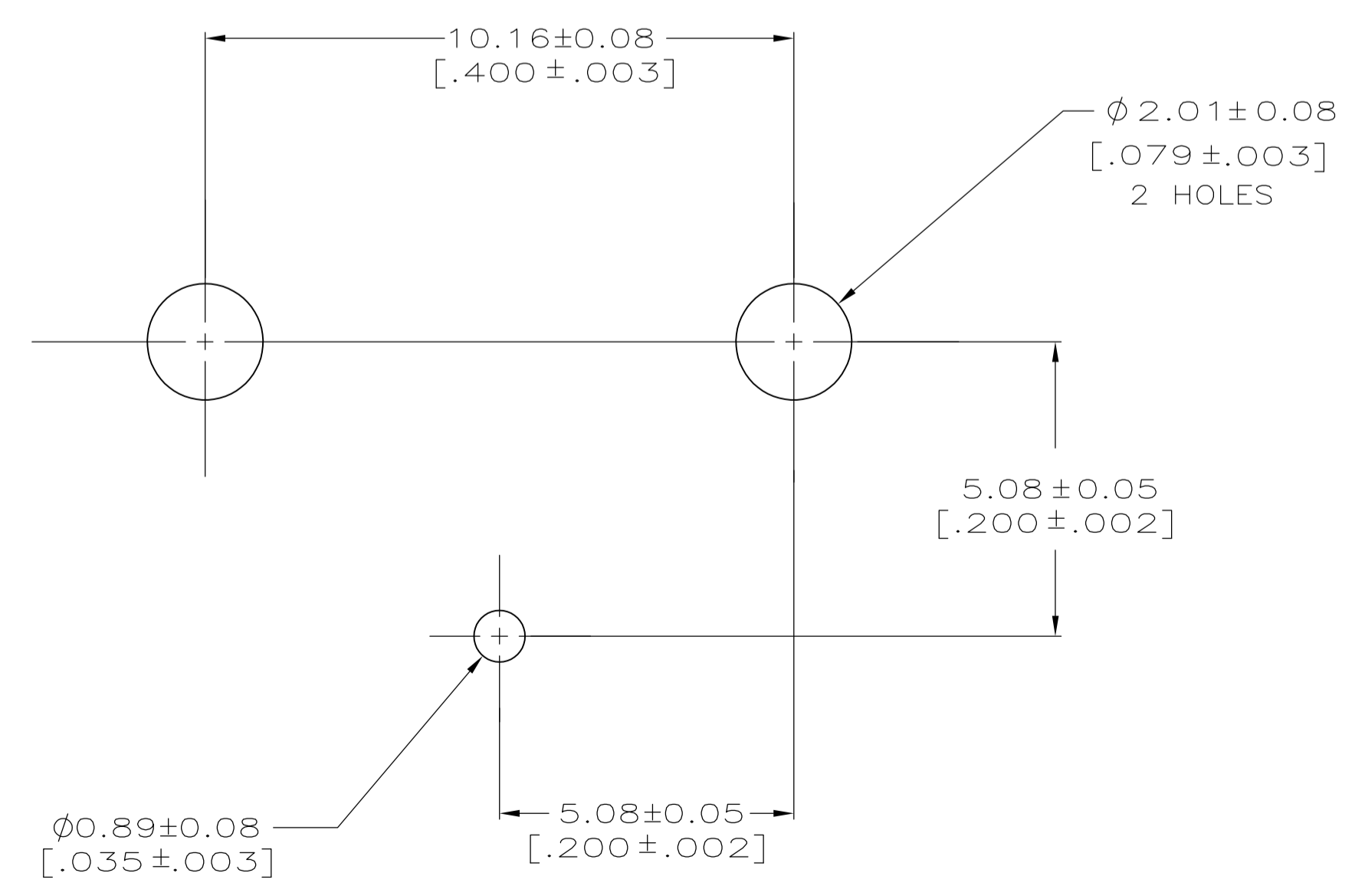

P.C.B. CONFIGURATION
SCALE=10:1

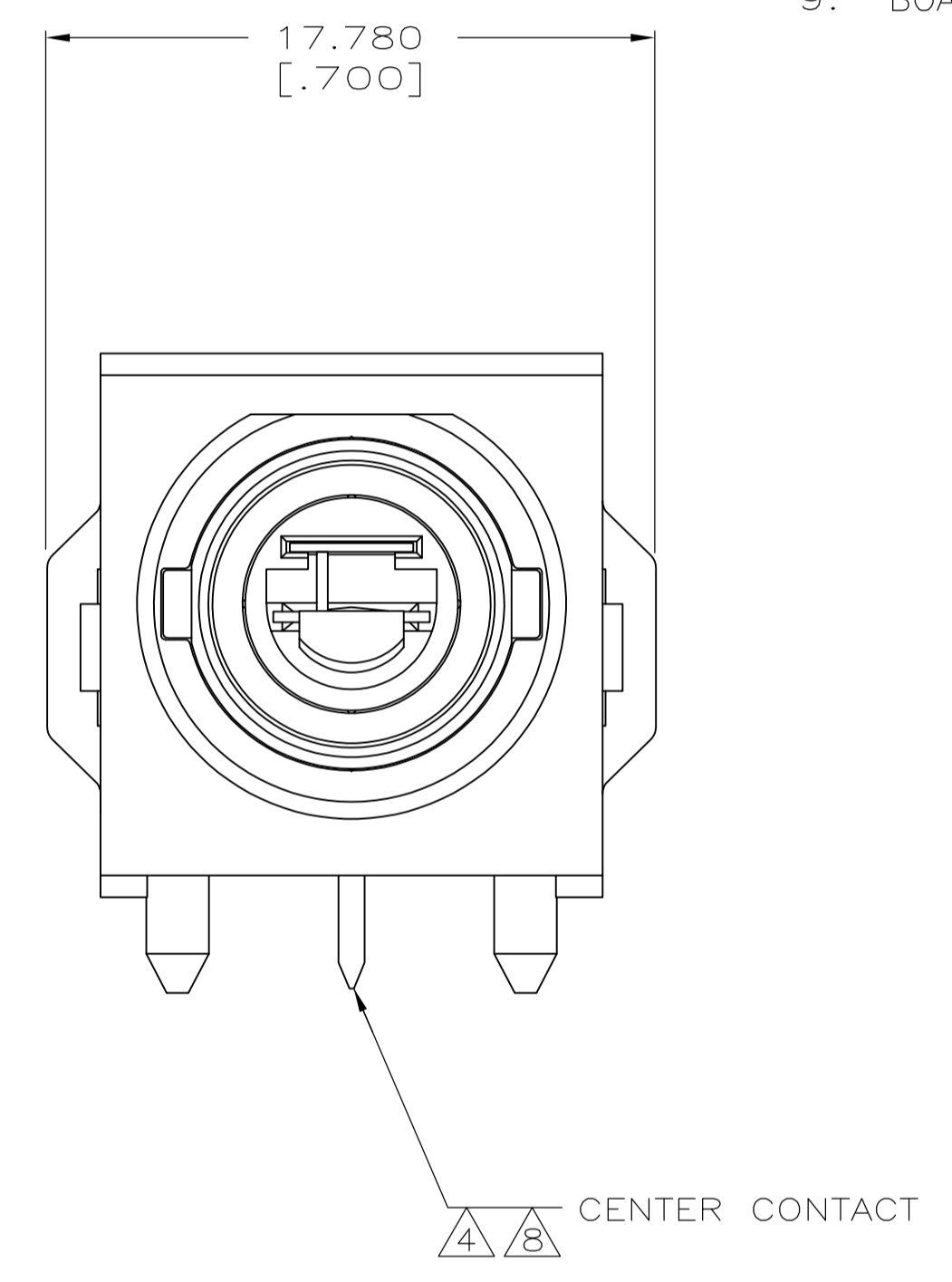
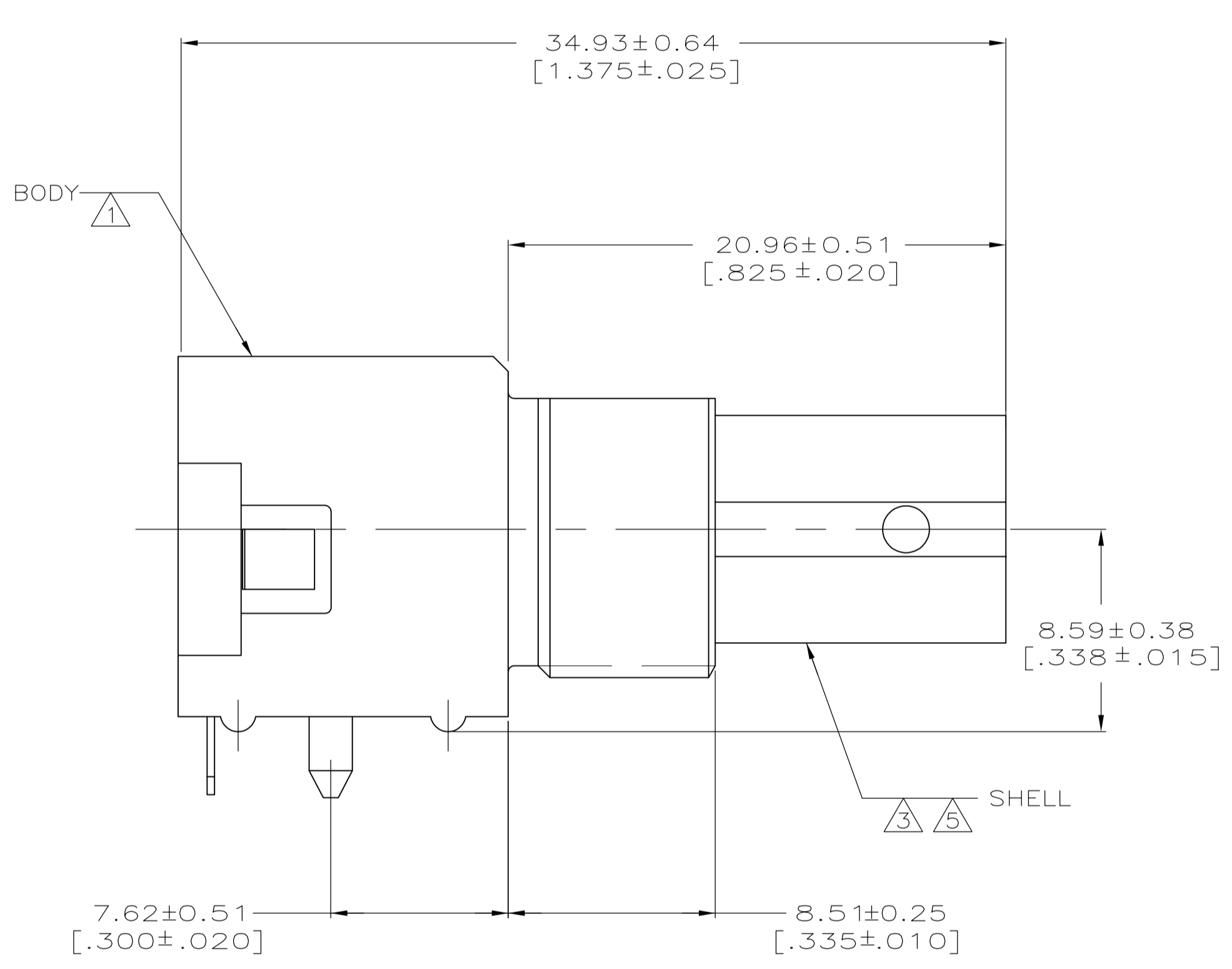
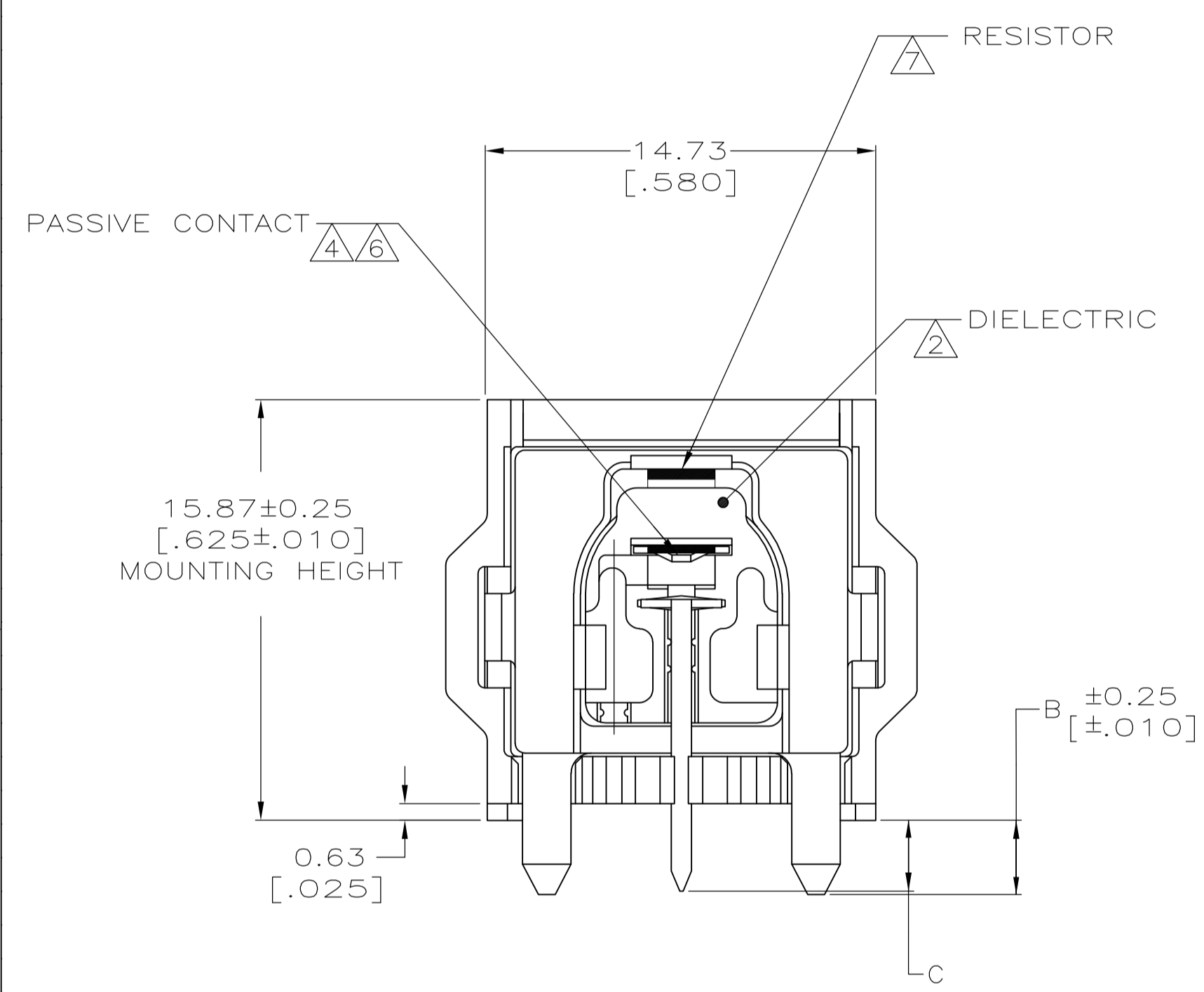
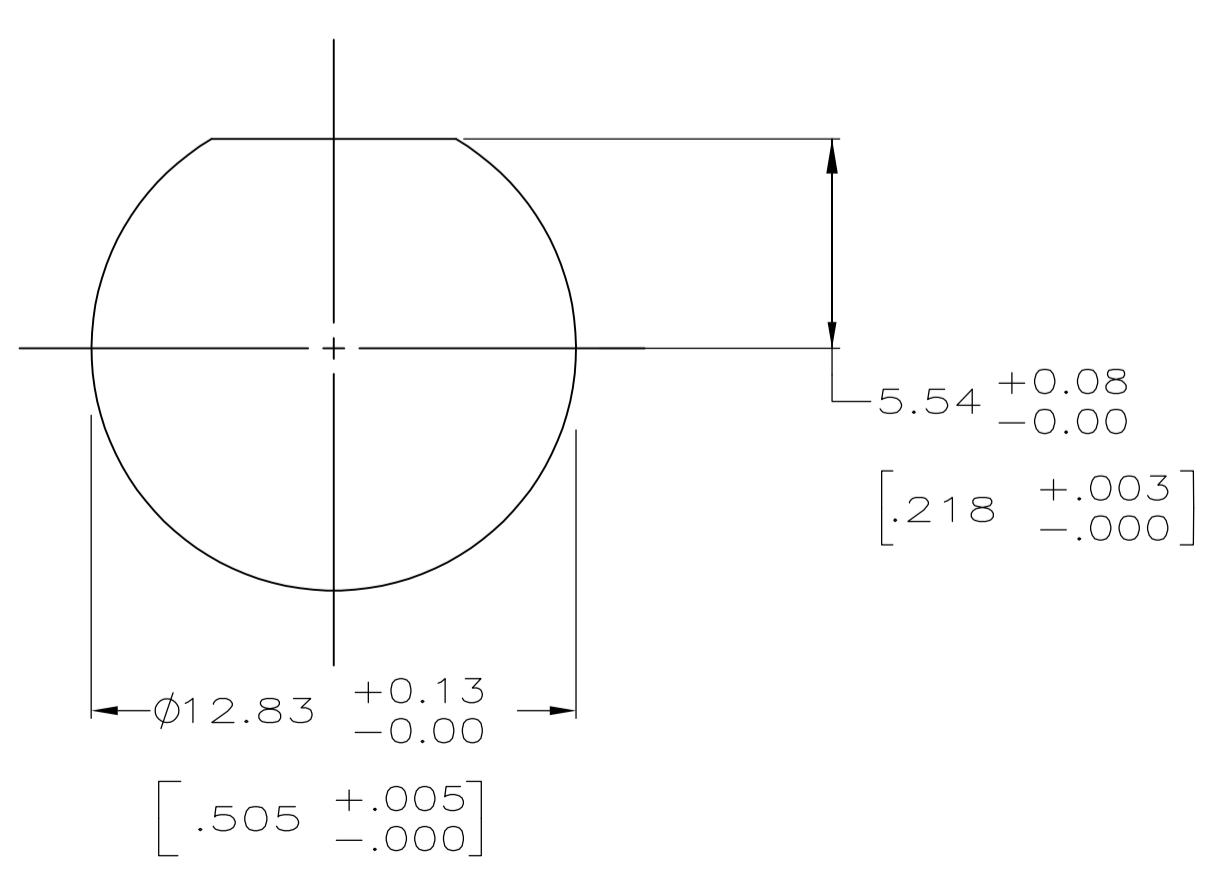

RECOMMENDED
PANEL CUTOUT

OBSOLETE	3.94 ^{+0.38} _{-0.51} [.155 ^{+0.15} _{-.020}]	4.06 [.160]	75 OHMS	414367-4
SUPSD BY 414367-2	2.67±0.38 [.105±.015]	2.79 [.110]	100 OHMS	414367-3
	2.67±0.38 [.105±.015]	2.79 [.110]	75 OHMS	414367-2
OBSOLETE	2.67±0.38 [.105±.015]	2.79 [.110]	50 OHMS	414367-1
	C	B	RESISTOR	PART NUMBER

THIS DRAWING IS A CONTROLLED DOCUMENT.

DIMENSIONS: INCHES	TOLERANCES UNLESS OTHERWISE SPECIFIED:	DIN P. KERLIN 02JUL92	CHK R. WEBER 02JUL92	APPRO R. WEBER 02JUL92	NAME
0 PLC ± -	1 PLC ± -	2 PLC ± -	3 PLC ± 0.20 [.008]	4 PLC ± -	ANGLES ± -
MATERIAL	FINISH	WEIGHT	SIZE	CAGE CODE	DRAWING NO
1 2 3 4	5 6 8	—	A1	00779	414367
CUSTOMER DRAWING			SCALE	SHEET	REV
			5:1	1 OF 1	H1

STE TE Connectivity

JACK,PCB,RIGHT ANGLE, SELF-TERMINATING BNC