

LOC		DIST		ZONE		LTR		REVISIONS		DATE	APPD
CM	53	P	F					0	RLSD PER PR CM 93-25	3-4-93	KS

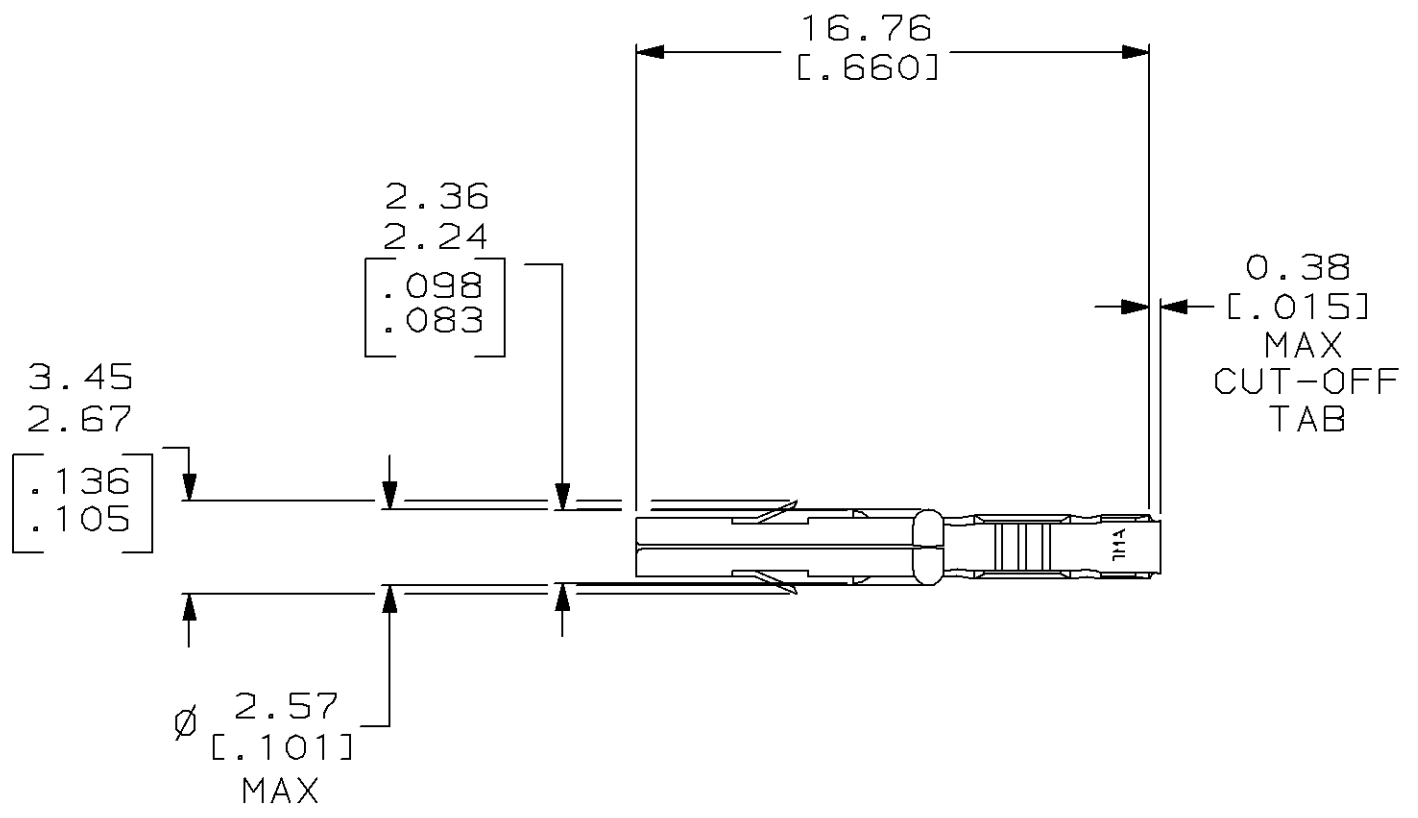

- 1. PLATED INTERNALLY WITH 0.00076 [.000030] GOLD, GOLD FLASH ON THE REMAINDER, OVER 0.00127 [.000050] NICKEL.
- 2. THIS CONTACT MATES WITH MR LIVE SPLIT PIN ONLY.
- 3. DIMENSIONS IN BRACKETS ARE IN INCHES.

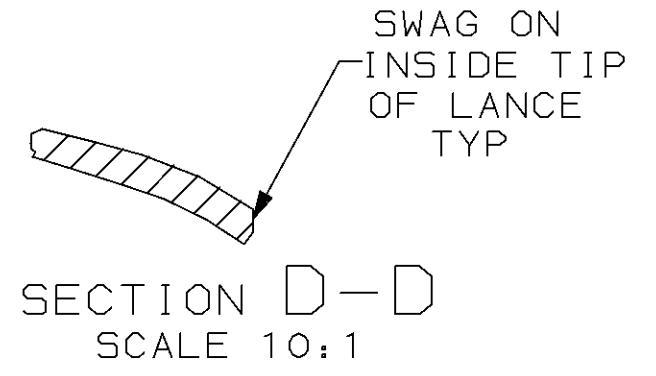
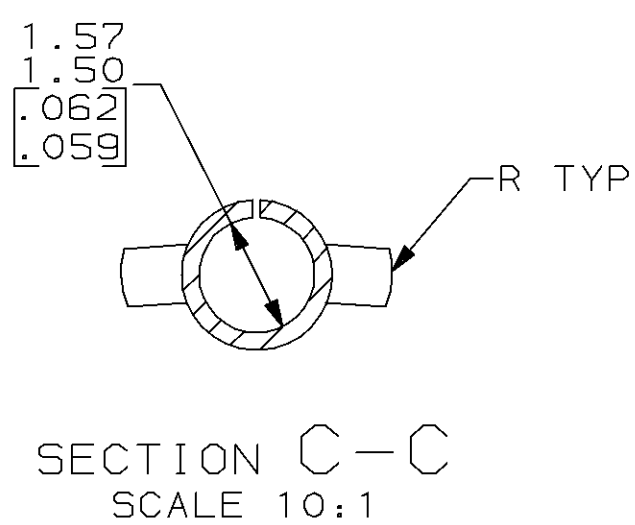
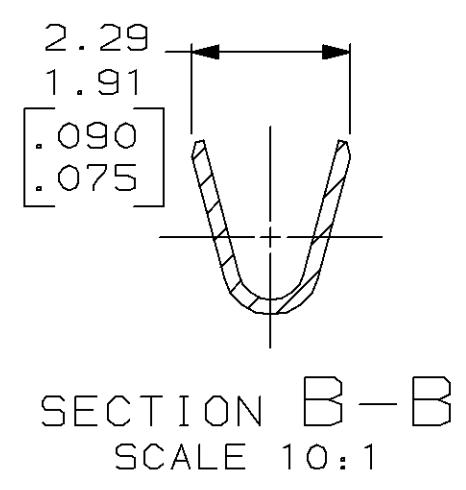
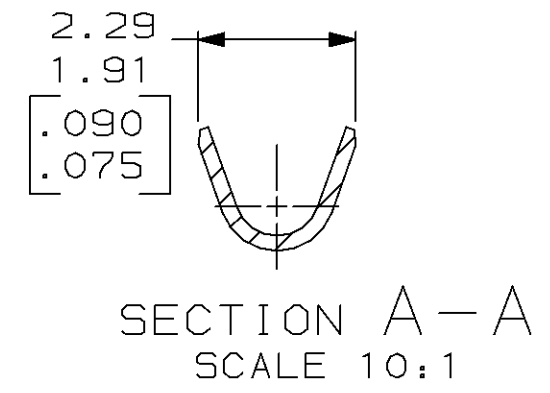
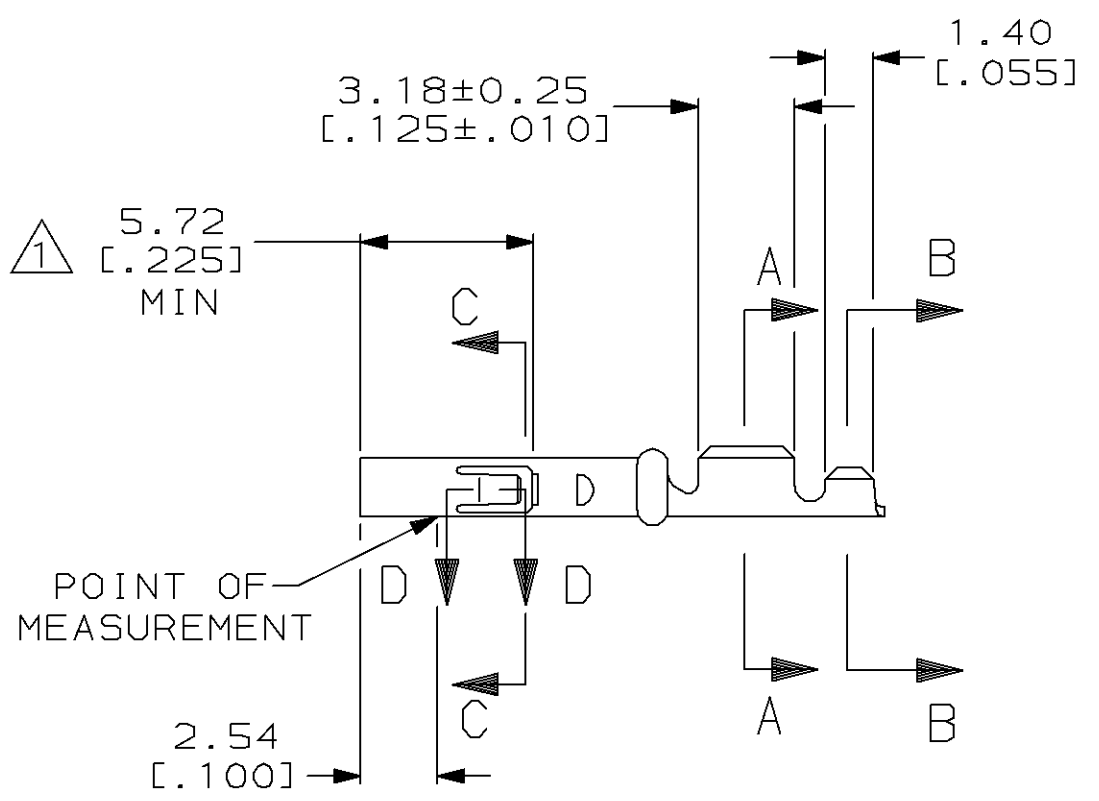

FINISH	MATERIAL	PART NO
GOLD Δ	0.20 [.008] PH BRZ	794001-2
PRE-TIN	0.20 [.008] PH BRZ	794001-1

DO NOT SCALE PRINT. UNLESS SPECIFIED DIMENSIONS IN mm [INCHES] TOLERANCES ON : 2 PLC DEC ± 0.13 [.005] 3 PLC DEC ± - ANGLES ± -	DR 3-4-93 K. SALMON	AMP AMP Incorporated Harrisburg, PA 17105-3608	
	CHK 3-4-93 R. SWING		
MATERIAL	APPD 3-4-93 J. ANDREW	NAME	
SEE TABLE	APPD 3-4-93 J. ANDREW	RECEPTACLE, LOOSE PIECE, MR	
FINISH	PRODUCT SPEC	SIZE	CAGE CODE
SEE TABLE	APPLICATION SPEC	③	00779
	WEIGHT	DRAWING NO	③=794001
		SCALE	4:1
		SHEET	1 OF 1

METRIC

THIS DRAWING IS A CONTROLLED DOCUMENT FOR AMP INCORPORATED. IT IS SUBJECT TO CHANGE AND THE CONTROLLING ENGINEERING ORGANIZATION SHOULD BE CONTACTED FOR THE LATEST REVISION.