

REVISIONS			
REV.	DESCRIPTION	DATE	APPROVED
A	INITIAL RELEASE	09/09/08	M.J.

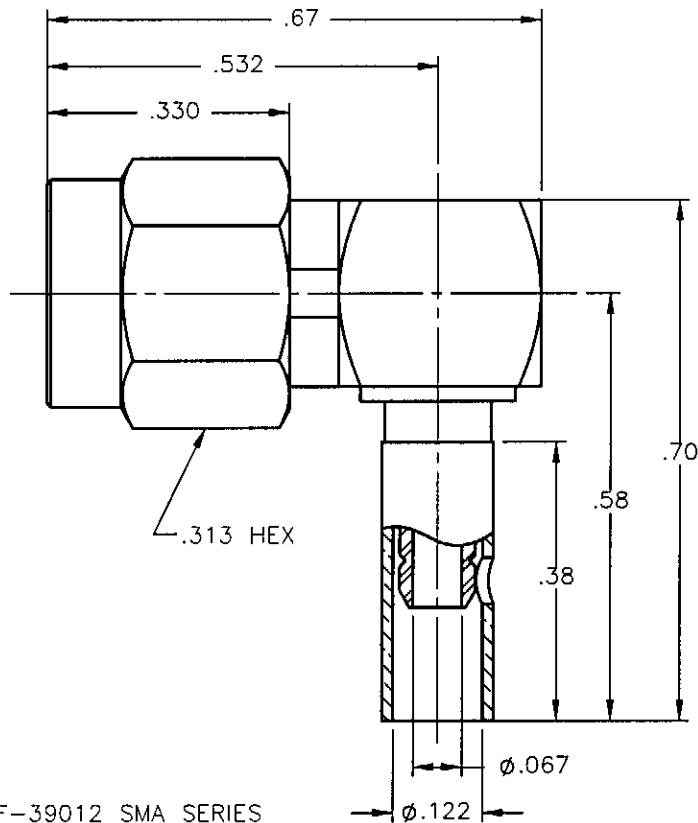

NOTES: CONFORMS TO MIL-PRF-39012 SMA SERIES



MATERIALS:

1. BODIES & COUPLING NUT = STAINLESS STEEL PER ASTM A582, ALLOY 303, CONDITION "A".
2. CONTACT & RETAINING RING = BERYLLIUM COPPER PER ASTM B196, ALLOY C17300, TEMPER TD04.
3. INSULATORS = VIRGIN WHITE TEFLON PER ASTM D1710, GRADE 1, TYPE I, CLASS "B".
4. GASKET = SILICONE RUBBER PER ZZ-R-765, CLASS 2B, GRADE 65-75.
5. CAP = BRASS PER ASTM B16, ALLOY C36000, TEMPER H02.
6. CRIMP SLEEVE = SEAMLESS COPPER TUBE PER ASTM B75, TYPE C12000, TEMPER: LIGHT ANNEAL 050 EXCEPT YIELD STRENGTH.
7. SHRINK SLEEVE = (NOT SHOWN) = THERMOFIT SCL, BLACK.

FINISHES:

1. BODIES = GOLD PLATE PER MIL-G-45204, TYPE II, CLASS 0, GRADE C, OVER .000050 TO .00010 STRESS FREE NICKEL PER QQ-N-290.
2. COUPLING NUT = PASSIVATE PER QQ-P-35, TYPE VI.
3. CONTACT = GOLD PLATE PER MIL-G-45204, TYPE II, CLASS 1, GRADE C, OVER .00010 TO .00020 STRESS FREE SULFAMATE NICKEL PER QQ-N-290.
4. ALL OTHER METAL PARTS = GOLD PLATE PER MIL-G-45204, TYPE II, CLASS 0, GRADE C, OVER .00010 TO .00020 COPPER STRIKE PER MIL-C-14550.

Property of Radiall Incorporated
 This document cannot be reproduced or
 communicated to a third party without prior
 written permission of RADIALL Incorporated.

UNLESS OTHERWISE SPECIFIED DIMENSIONS ARE IN INCHES TOLERANCES ON	DWN:	DATE	 APPLIED ENGINEERING PRODUCTS 104 John W. Murphy Dr. New Haven, CT 06513 <i>a RADIALL company</i>				
	M.J.	09/09/08					
DECIMAL	ANGLE	CHKD:	DATE	SMA RIGHT ANGLE PLUG CRIMP/SOLDER TYPE FOR RG-316 & SIMILAR CABLES			
		D.N.	09/09/08				
		APVD:	DATE				
REFERENCE:	MATERIALS & FINISHES:	J.M.	09/09/08	SIZE	FSCM NO.	DWG NO.	REV
ORIGINATED: M.J.	SEE NOTES			A	19505	9043-1533-003	A
DATE: 09/09/08				SCALE 4:1	THIRD ANGLE PROJECTION		SHEET 1 OF 1

9043-1533-003