

**SAVE 40% IN PANEL SPACE AND COST:** Packaged in a 72mm<sup>2</sup> DIN-size housing, the 356 occupies 40% less panel space than previous IC timers. Modern production and assembly techniques have substantially reduced manufacturing costs resulting in a 45% cost saving.

**LOW INVENTORY COSTS:** Each Shawnee 356 covers the active count range of 1 to 9,999, easily satisfying the vast majority of industrial requirements and thus greatly reducing inventory.

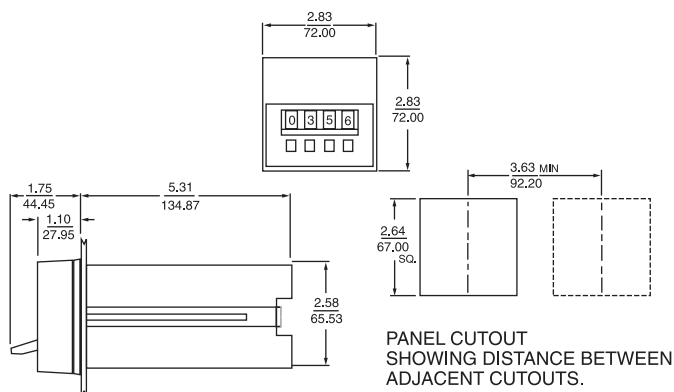

## DIMENSIONS (INCHES/MILLIMETERS)



## Shawnee II Digital Counter

A compact version of the 336 counter, the ATC 356 is its exact functional duplicate. Packaged in a 72mm<sup>2</sup> DIN-size housing, it occupies 40% less panel space and costs proportionately less. Modern production and assembly techniques have all but eliminated hand wiring, enhancing the reliability and life expectancy of the 356.

**FAST, ACCURATE AND BOUNCE-PROOF:** The repeat accuracy of the 356 is 100%. It maintains full accuracy even at pulse rates up to 4,000/minute, even with pulses that are as brief as 1 millisecond, and even in the face of severe contact bounce, which it ignores by virtue of an extremely effective anti-bounce circuit.

**EASY TO SET AT ALL TIMES:** The Shawnee counter is easily and accurately set even with work gloves on. Push any of its four toggle levers in any sequence until the number you want appears above it. You can decrease as well as increase each number by pushing the levers up or down. You can change the setting at any time, even during a cycle.

**PLUG-IN AND DUST-TIGHT:** All 356 counters feature true plug-in design and can be replaced in seconds without disturbing the housing or disconnecting the wiring. The dial assembly is gasketed so that the counter body is dust-tight from the front of panel.

**CYCLE PROGRESS INDICATION:** The Shawnee 356 indicating counter provides cycle progress indication on the four-digit display located immediately above the digital setting number wheels. When the counter is in the reset condition, the VFD display is blank. During the cycle, the display counts up from 0, thus always indicating the number of counts that have elapsed since the start of cycle. At count-out, the display shows the total elapsed count and thus equals the numbers on the digital setting wheels.

**COMPUTER-TESTED RELIABILITY:** The solid-state 356 is manufactured from a series of computer-tested plug-in circuit boards and assembled virtually without hand wiring. Because it has no moving parts in its logic circuits, its life expectancy is practically unlimited. Even the load relay – the 356's only significant mechanical component – has a life expectancy of 10,000,000 operations (no load). As a result the 356 achieves an overall reliability that surpasses even that achieved by previous Shawnee counters.

**NOISE IMMUNITY:** The 356 does not have to be shielded: its transformer power supply, full-wave bridges, buffered logic and other design characteristics render it immune to the electrical noise that is sometimes encountered in industrial environments thus eliminating false starts and reset due to voltage spikes.

## MODEL NUMBER

MODEL NUMBER	356C			30	P	
<b>RANGE</b>						
9,999 Counts	350					
99,990 Counts (units digit blind)	353					
Special	000					
<b>VOLTAGE &amp; FREQUENCY</b>						
120 VAC 50-60 Hz			Q			
240 VAC, 50-60 Hz			R			
<b>ARRANGEMENT</b>						
With Display (On-Delay)				30		
<b>FEATURES</b>						
Basic plug-in unit					P	
Standard unit						X
Special						K
<b>ACCESSORIES</b>						
Surface mounting bracket kit						0353-260-27-00
Retrofit kit						0305-265-61-70

The 356C Directly Replaces 356B & 356A.

## OPERATION

The Shawnee 356 operates on a digital logic circuit with three main elements: a pulse circuit; a read-only-memory (ROM) whose output is set by the counter's digital setting number wheels; and a comparator that continuously examines the outputs of the pulse circuit and ROM.

When power is applied (start signal on), two things happen simultaneously; the instantaneous DPDT relay is energized transferring both sets of contacts, and the pulse circuit begins to count each input pulse whose duration is at least 1 millisecond. The pulse circuit accumulates the count and feeds the total continuously to the comparator. When pulse circuit output exactly equals the output of the ROM, the comparator causes the 356 to count out.

At this point, (1) the DPDT delay relay is energized, immediately transferring both sets of contacts and (2) the pulse circuit turns itself off automatically. Since the pulse circuit stops counting even if the start signal remains on, it is not necessary to tie up one of the 356's delayed contacts to do this job.

To reset the 356, power must be removed from terminal 1 (L1) for 75 milliseconds or more. The 356 operates in the on-delay mode only, always resetting whenever there is a power outage and starting a new cycle when power is restored.

RELAY	CONTACTS	Switching Sequence*		
		Before Start	During Timing	End of Cycle
Instantaneous	14-9/6-8			
	14-10/6-7			
Delayed (D2)	11-12/4-5			
	11-13/4-3			

\*Assumes a sustained closed start signal (i.e. longer than the setting on the digital display)

BLACK— CIRCUIT CLOSED  
 GRAY— CIRCUIT OPEN

## WIRING

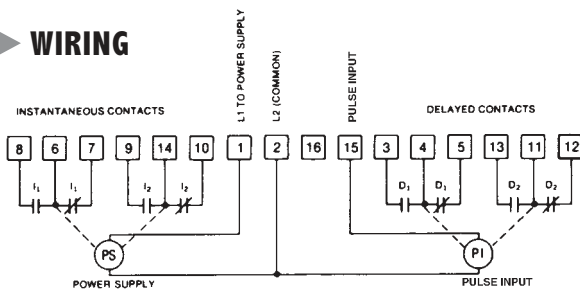

TERMINAL WIRING:  
INDICATING MODEL

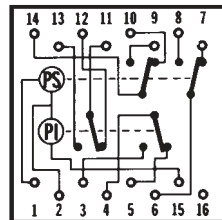

## SPECIFICATIONS

<b>RANGE</b>	1 to 9999 counts or 10 to 99,990, presettable in 10 count increments.	
<b>COUNT INPUT</b>	2300/MIN with 1:1 on-off time 4000/MIN with 1 mSEC on: 13 mSEC off 500/MIN with 20 mSEC on and 100 mSEC off Wired for count and repeat operation Min. Pulse ON Time: 1 mSEC Min. Pulse OFF Time: 13 mSEC Ready-To-Count Time 10 mSEC after application of power to terminals 1 and 2 Bounce Immunity 6 mSEC (max. bounce open time) Pulse Contact Req. 30mA (at line voltage)	
<b>CYCLE PROGRESS INDICATOR</b>	4 digit, 0.3 inch, high intensity, blue display.	
<b>REPEAT ACCURACY</b>	100%	
<b>RESET TIME</b>	75 mSEC minimum	
<b>MINIMUM SETTING</b>	1 count	
<b>COUNT CONTROL MODES</b>	Single Cycle	interval or delayed
	Repeat Cycle	pulses
<b>LOAD RELAYS</b>	Number	two, one instantaneous and one delayed; both plug-in, DPDT
	Operate Time	20 mSEC max.
	Release Time	instantaneous—20 mSEC, max. delayed—75 mSEC, max.
	Contact Rating	5A at 120 VAC. 2A at 240 VAC, 0.1A at 125 VDC
	Life	100 million operations (no load.)
<b>TEMPERATURE RATING</b>	32° to 140°F (0° to 60°C)	
<b>POWER REQUIREMENTS</b>	120V	95-132V at 50 or 60 Hz inrush -0.4A running —0.08A
	240V	190-264V at 50 or 60Hz inrush - 0.2A running—0.04A
<b>TERMINALS</b>	16 screw terminals accessible at rear; integral wiring diagram on housing.	
<b>HOUSING</b>	Plug-in design; completely gasketed, dust-tight when panel-mounted.	
<b>MOUNTING ACCESSORIES</b>	Standard	Hardware is provided to mount timer so that it is dust-tight from front of panel.
	Optional	Surface mounting without and with front-facing terminals.
<b>WEIGHT</b>	NET: 1 lb., 7 oz.	SHIPPING: 2 lbs

# TYPICAL INSTALLATIONS

- Ⓟ POWER SUPPLY
- Ⓟ PULSE INPUT
- INDEPENDENT LOADS
- DEPENDENT LOADS
- Ⓞ MOMENTARY STARTING CONTACT
- Ⓞ SUSTAINED STARTING CONTACT
- Ⓞ NORMALLY CLOSED RESET CONTACT
- LOAD DE-ENERGIZED
- Ⓧ LOAD ENERGIZED

Ⓟ DELAYED CONTACTS  
 Contacts transfer simultaneously when unit "times out" and all digits are zero.

All timers shown in "before start" position. Diagrams shown with power off unless otherwise marked.

Maximum load current through any load carrying contact is 5 amperes.

Pilot light leads are brought out to terminal block. Pilot light can be wired to show practically any desired function; unit energized, cycle running, instantaneous or delayed switch closed, etc.

ON DELAY—Reset on power failure.

Ⓟ INSTANTANEOUS CONTACTS  
 Contacts are transferred when power supply is energized; transferred back as shown when de-energized.

## SUSTAINED START

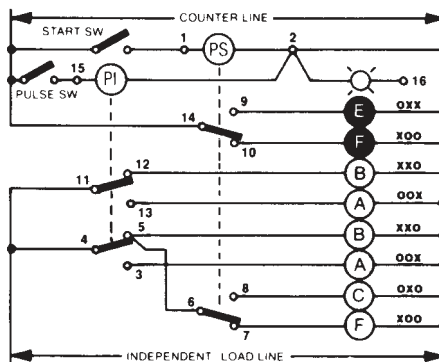

## MOMENTARY START/SUSTAINED START

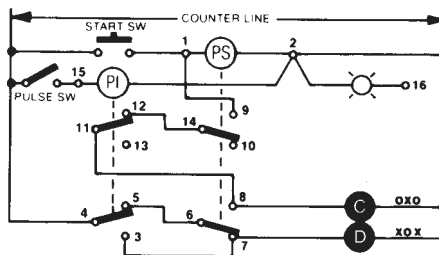

## COUNT, PULSE AND REPEAT CYCLE

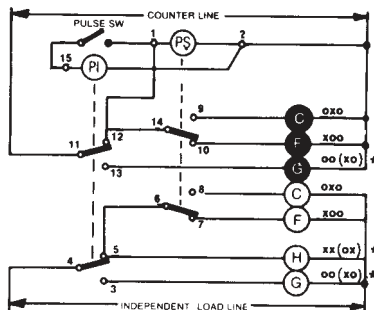

**NOTE: Minimum sw open time: 100 ms.  
 Minimum sw close time: 20 ms.  
 Output Pulse length — approx. 50 ms.**