

Chip Multilayer Diplexers

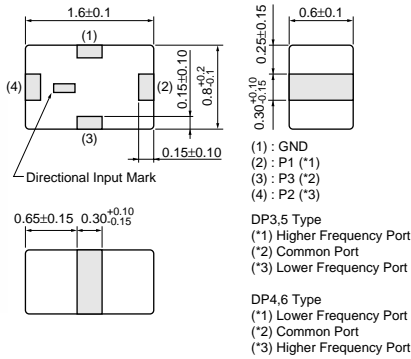

LFD18_DP Series



All the technical data and information contained herein are subject to change without prior notice. (in mm)



LFD18_DPF Series

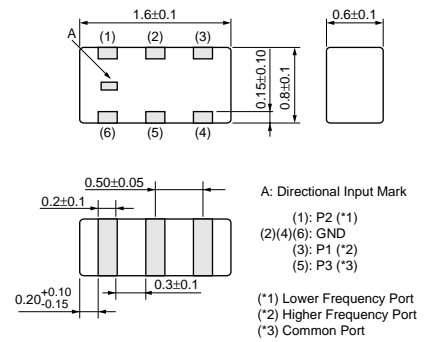

(in mm)



LFD18_DPG Series

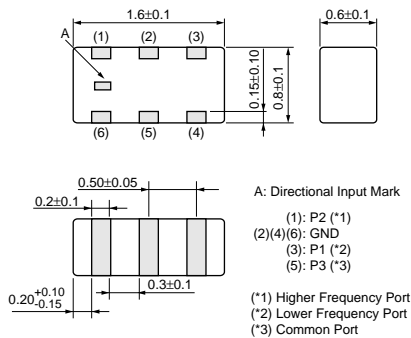

(in mm)



LFD21_DP3 Series

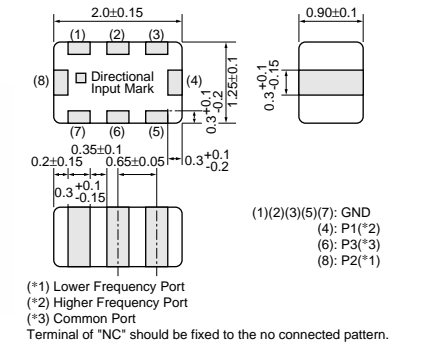

All the technical data and information contained herein are subject to change without prior notice. (in mm)



LFD21_DP4 Series

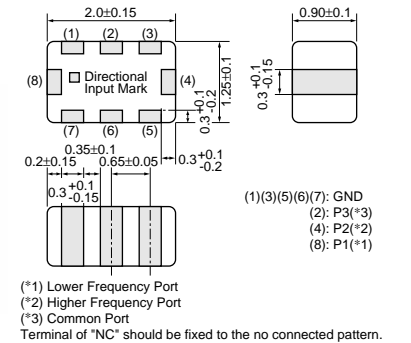

All the technical data and information contained herein are subject to change without prior notice. (in mm)



LFD21_DPH Series

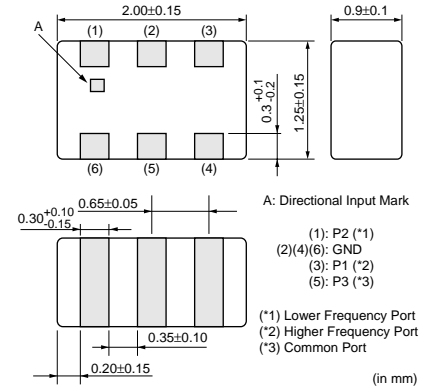

(in mm)



LFD21_DP1 Series

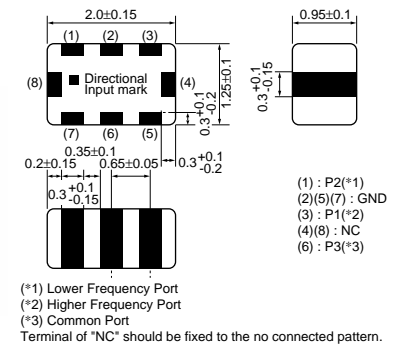

All the technical data and information contained herein are subject to change without prior notice. (in mm)



LFD21_DP2 Series

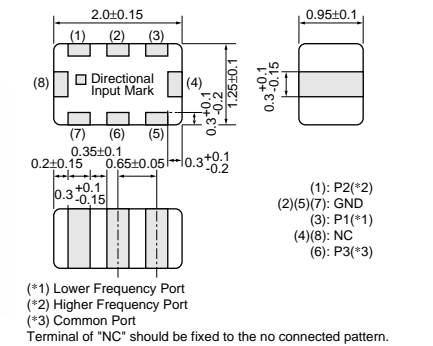

All the technical data and information contained herein are subject to change without prior notice. (in mm)

Continued on the following page.

Note • This PDF catalog is downloaded from the website of Murata Manufacturing co., Ltd. Therefore, it's specifications are subject to change or our products in it may be discontinued without advance notice. Please check with our sales representatives or product engineers before ordering.
 • This PDF catalog has only typical specifications because there is no space for detailed specifications. Therefore, please approve our product specifications or transact the approval sheet for product specifications before ordering.

Continued from the preceding page.

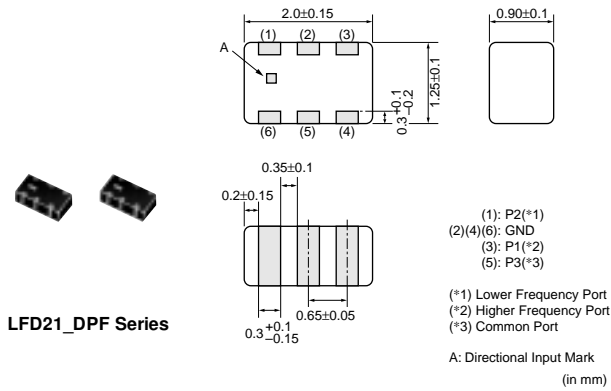

LFD21_DPF Series

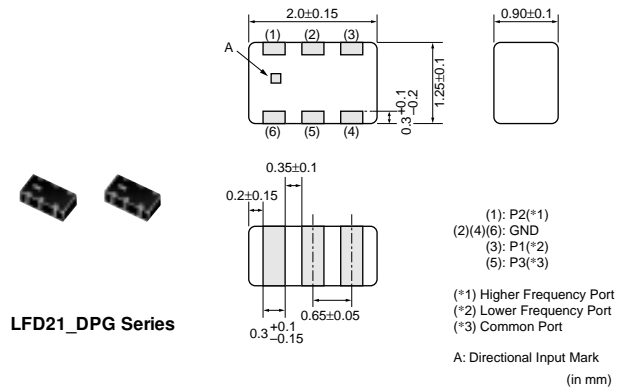

LFD21_DPG Series

Part Number	Frequency Range (f1) (MHz)	Frequency Range (f2) (MHz)	Insertion Loss (I) (P1-P3 in f1) (dB)	Insertion Loss (II) (P2-P3 in f1) (dB)	Attenuation [P1-P3](in f2) (dB)	Attenuation [P2-P3](in f1) (dB)
LFD181G57DP5B910	2450 ±50.0MHz	1575.5 ±1.5MHz	0.8 max. (at 25°C)	0.65 max. (at 25°C)	20 min.	20 min.
LFD181G57DP6B913	1575.5 ±1.5MHz	2450 ±50.0MHz	0.65 max. (at 25°C)	0.80 max. (at 25°C)	20 min.	20 min.
LFD181G57DPFC087	2450 ±50.0MHz	1575 ±3.0MHz	0.5 max. (at 25°C)	0.35 max. (at 25°C)	22 min.	13 min.
LFD181G57DPGC092	1575 ±3.0MHz	2450 ±50.0MHz	0.35 max. (at 25°C)	0.5 max. (at 25°C)	13 min.	22 min.
LFD182G45DP3A299	5375 ±475.0MHz	2450 ±50.0MHz	0.60 max. (at 25°C)	0.40 max. (at 25°C)	20 min.	20 min.
LFD182G45DP3B888	5375 ±475.0MHz	2450 ±50.0MHz	0.60 max. (at 25°C)	0.40 max. (at 25°C)	20 min.	20 min.
LFD182G45DP4B720	2450 ±50.0MHz	5375 ±475.0MHz	0.40 max. (at 25°C)	0.60 max. (at 25°C)	20 min.	20 min.
LFD182G45DP4B889	2450 ±50.0MHz	5375 ±475.0MHz	0.40 max. (at 25°C)	0.60 max. (at 25°C)	20 min.	20 min.
LFD212G45DP3A140	5250 ±100.0MHz	2450 ±50.0MHz	0.65 max. (at 25°C)	0.50 max. (at 25°C)	20 min.	20 min.
LFD212G45DP3A151	5487.5 ±337.5MHz	2450 ±50.0MHz	0.75 max. (at 25°C)	0.50 max. (at 25°C)	20 min.	16 min.
LFD212G45DP3A188	5375 ±475.0MHz	2450 ±50.0MHz	0.75 max. (at 25°C)	0.50 max. (at 25°C)	21 min.	17 min.
LFD212G45DP4A189	2450 ±50.0MHz	5375 ±475.0MHz	0.5 max. (at 25°C)	0.75 max. (at 25°C)	17 min.	21 min.
LFD21452MDPHC192	859.0 ±35.0MHz	452.5 ±41.5MHz	0.50 max. (at 25°C)	0.65 max. (at 25°C)	15 min.	17 min.
LFD21859MDP1A049	1920 ±70.0MHz	859 ±35.0MHz	0.45 max. (at 25°C)	0.40 max. (at 25°C)	19 min.	20 min.
LFD21859MDP2A076	859 ±35.0MHz	1920 ±70.0MHz	0.40 max. (at 25°C)	0.45 max. (at 25°C)	20 min.	19 min.
LFD21874MDP1A084	1575.5 ±3.0MHz	874 ±51.0MHz	0.60 max. (at 25°C)	0.55 max. (at 25°C)	25 min.	23 min.
LFD21874MDP2A181	874 ±51.0MHz	1575.5 ±3.0MHz	0.55 max. (at 25°C)	0.60 max. (at 25°C)	23 min.	25 min.
LFD21884MDP1A062	1906.5 ±13.0MHz	884 ±74.0MHz	0.45 max. (at 25°C)	0.50 max. (at 25°C)	20 min.	20 min.
LFD21892MDP1A141	1850 ±140.0MHz	892 ±68.0MHz	0.60 max. (at 25°C)	0.40 max. (at 25°C)	19 min.	17 min.
LFD21892MDP2B860	892 ±68.0MHz	1850 ±140.0MHz	0.40 max. (at 25°C)	0.60 max. (at 25°C)	17 min.	19 min.
LFD21892MDPFC065	1940 ±230.0MHz	892 ±68.0MHz	0.45 max. (at 25°C)	0.27 max. (at 25°C)	19 min.	13 min.
LFD21892MDPGC103	892 ±68.0MHz	1940 ±230.0MHz	0.27 max. (at 25°C)	0.45 max. (at 25°C)	13 min.	19 min.
LFD21920MDP1A048	1795 ±85.0MHz	920 ±40.0MHz	0.55 max. (at 25°C)	0.50 max. (at 25°C)	20 min.	16 min.

Note • This PDF catalog is downloaded from the website of Murata Manufacturing co., Ltd. Therefore, it's specifications are subject to change or our products in it may be discontinued without advance notice. Please check with our sales representatives or product engineers before ordering.
 • This PDF catalog has only typical specifications because there is no space for detailed specifications. Therefore, please approve our product specifications or transact the approval sheet for product specifications before ordering.