

ADC1410S series

Single 14-bit ADC; 65 Msps, 80 Msps, 105 Msps or 125 Msps;
CMOS or LVDS DDR digital outputs

Rev. 05 — 2 July 2012

Product data sheet

1. General description

The ADC1410S is a single-channel 14-bit Analog-to-Digital Converter (ADC) optimized for high dynamic performance and low power consumption at sample rates up to 125 Msps. Pipelined architecture and output error correction ensure the ADC1410S is accurate enough to guarantee zero missing codes over the entire operating range. Supplied from a single 3 V source, it can handle output logic levels from 1.8 V to 3.3 V in CMOS mode, because of a separate digital output supply. It supports the Low Voltage Differential Signalling (LVDS) Double Data Rate (DDR) output standard. An integrated Serial Peripheral Interface (SPI) allows the user to easily configure the ADC. The device also includes a programmable full-scale SPI to allow a flexible input voltage range from 1 V to 2 V (peak-to-peak). With excellent dynamic performance from the baseband to input frequencies of 170 MHz or more, the ADC1410S is ideal for use in communications, imaging and medical applications.

2. Features and benefits

- SNR, 72 dBFS; SFDR, 86 dBc
- Sample rate up to 125 Msps
- 14-bit pipelined ADC core
- Clock input divided by 2 for less jitter
- Single 3 V supply
- Flexible input voltage range: 1 V (p-p) to 2 V (p-p)
- Offset binary, two's complement, gray code
- Power-down and Sleep modes
- Input bandwidth, 600 MHz
- Power dissipation, 430 mW at 80 Msps
- Serial Peripheral Interface (SPI)
- Duty cycle stabilizer
- Fast Out of Range (OTR) detection
- CMOS or LVDS DDR digital outputs
- Pin compatible with the ADC1210S series and the ADC1010S series
- HVQFN40 package

3. Applications

- Wireless and wired broadband communications
- Spectral analysis
- Ultrasound equipment
- Portable instrumentation
- Imaging systems
- Software defined radio



4. Ordering information

Table 1. Ordering information

Type number	f _s (MSPs)	Package		Version
		Name	Description	
ADC1410S125HN-C1	125	HVQFN40	plastic thermal enhanced very thin quad flat package; no leads; 40 terminals; body 6 × 6 × 0.85 mm	SOT618-1
ADC1410S105HN-C1	105	HVQFN40	plastic thermal enhanced very thin quad flat package; no leads; 40 terminals; body 6 × 6 × 0.85 mm	SOT618-1
ADC1410S080HN-C1	80	HVQFN40	plastic thermal enhanced very thin quad flat package; no leads; 40 terminals; body 6 × 6 × 0.85 mm	SOT618-1
ADC1410S065HN-C1	65	HVQFN40	plastic thermal enhanced very thin quad flat package; no leads; 40 terminals; body 6 × 6 × 0.85 mm	SOT618-1

5. Block diagram

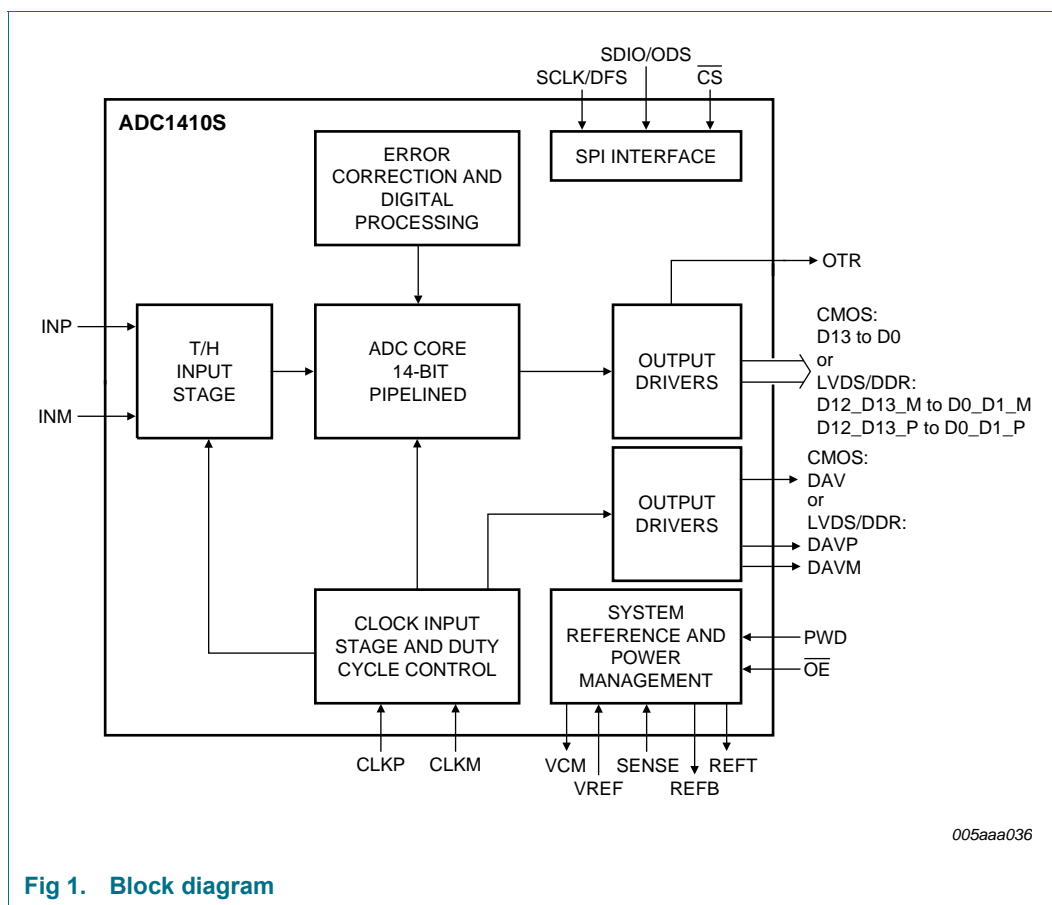

Fig 1. Block diagram

6. Pinning information

6.1 Pinning

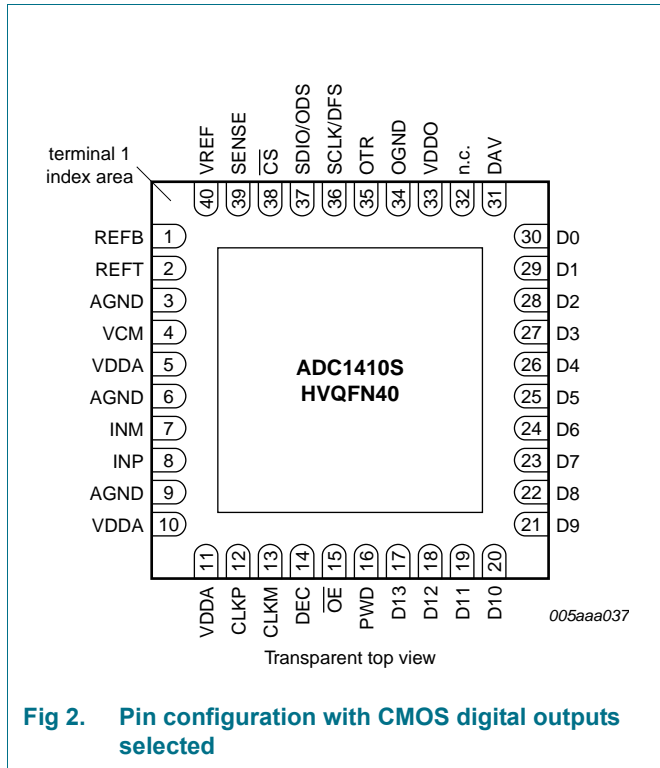

Fig 2. Pin configuration with CMOS digital outputs selected

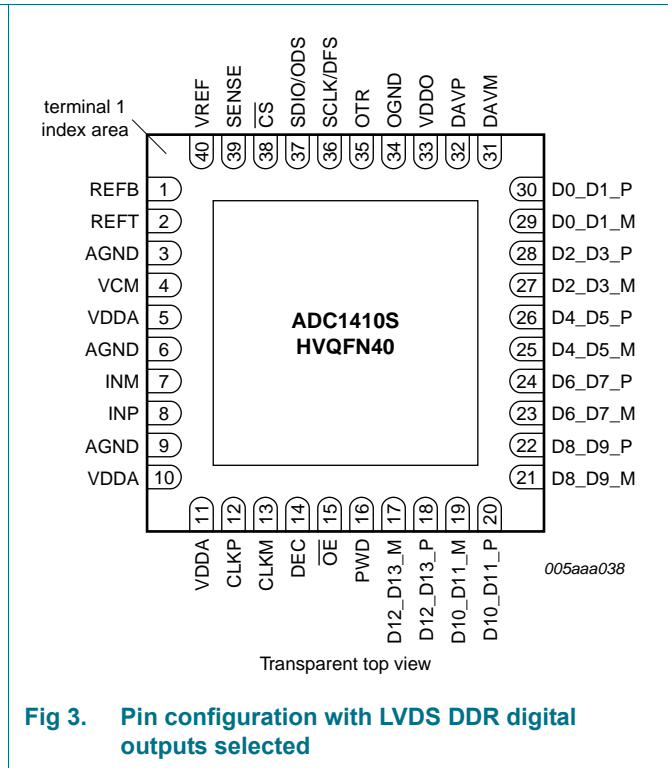

Fig 3. Pin configuration with LVDS DDR digital outputs selected

6.2 Pin description

Table 2. Pin description (CMOS digital outputs)

Symbol	Pin	Type ^[1]	Description
REFB	1	O	bottom reference
REFT	2	O	top reference
AGND	3	G	analog ground
VCM	4	O	common-mode output voltage
VDDA	5	P	analog power supply
AGND	6	G	analog ground
INM	7	I	complementary analog input
INP	8	I	analog input
AGND	9	G	analog ground
VDDA	10	P	analog power supply
VDDA	11	P	analog power supply
CLKP	12	I	clock input
CLKM	13	I	complementary clock input
DEC	14	O	regulator decoupling node
OE	15	I	output enable, active LOW
PWD	16	I	power-down, active HIGH

Table 2. Pin description (CMOS digital outputs) ...continued

Symbol	Pin	Type ^[1]	Description
D13	17	O	data output bit 13 (Most Significant Bit (MSB))
D12	18	O	data output bit 12
D11	19	O	data output bit 11
D10	20	O	data output bit 10
D9	21	O	data output bit 9
D8	22	O	data output bit 8
D7	23	O	data output bit 7
D6	24	O	data output bit 6
D5	25	O	data output bit 5
D4	26	O	data output bit 4
D3	27	O	data output bit 3
D2	28	O	data output bit 2
D1	29	O	data output bit 1
D0	30	O	data output bit 0 (Least Significant Bit (LSB))
DAV	31	O	data valid output clock
n.c.	32	-	not connected
VDDO	33	P	output power supply
OGND	34	G	output ground
OTR	35	O	out of range
SCLK/DFS	36	I	SPI clock data format select
SDIO/ODS	37	I/O	SPI data IO output data standard
$\overline{\text{CS}}$	38	I	SPI chip select
SENSE	39	I	reference programming pin
VREF	40	I/O	voltage reference input/output

[1] P: power supply; G: ground; I: input; O: output; I/O: input/output.

Table 3. Pin description (LVDS/DDR) digital outputs)

Symbol	Pin ^[1]	Type ^[2]	Description
D12_D13_M	17	O	differential output data D12 and D13 multiplexed, complement
D12_D13_P	18	O	differential output data D12 and D13 multiplexed, true
D10_D11_M	19	O	differential output data D10 and D11 multiplexed, complement
D10_D11_P	20	O	differential output data D10 and D11 multiplexed, true
D8_D9_M	21	O	differential output data D8 and D9 multiplexed, complement
D8_D9_P	22	O	differential output data D8 and D9 multiplexed, true
D6_D7_M	23	O	differential output data D6 and D7 multiplexed, complement
D6_D7_P	24	O	differential output data D6 and D7 multiplexed, true
D4_D5_M	25	O	differential output data D4 and D5 multiplexed, complement
D4_D5_P	26	O	differential output data D4 and D5 multiplexed, true
D2_D3_M	27	O	differential output data D2 and D3 multiplexed, complement
D2_D3_P	28	O	differential output data D2 and D3 multiplexed, true
D0_D1_M	29	O	differential output data D0 and D1 multiplexed, complement

Table 3. Pin description (LVDS/DDR) digital outputs) ...continued

Symbol	Pin ^[1]	Type ^[2]	Description
D0_D1_P	30	O	differential output data D0 and D1 multiplexed, true
DAVM	31	O	data valid output clock, complement
DAVP	32	O	data valid output clock, true

[1] Pins 1 to 16 and pins 33 to 40 are the same for both CMOS and LVDS DDR outputs (see Table 2).

[2] P: power supply; G: ground; I: input; O: output; I/O: input/output.

7. Limiting values

Table 4. Limiting values

In accordance with the Absolute Maximum Rating System (IEC 60134).

Symbol	Parameter	Conditions	Min	Max	Unit
V _O	output voltage	pins D13 to D0 or pins D12_D13_M to D0_D1_M and pins D12_D13_P to D0_D1_P	-0.4	+3.9	V
V _{DDA}	analog supply voltage		-0.4	+3.9	V
V _{DDO}	output supply voltage		-0.4	+3.9	V
T _{stg}	storage temperature		-55	+125	°C
T _{amb}	ambient temperature		-40	+85	°C
T _j	junction temperature		-	125	°C

8. Thermal characteristics

Table 5. Thermal characteristics

Symbol	Parameter	Conditions	Typ	Unit
R _{th(j-a)}	thermal resistance from junction to ambient		^[1] 22.5	K/W
R _{th(j-c)}	thermal resistance from junction to case		^[1] 11.7	K/W

[1] Value for six layers board in still air with a minimum of 25 thermal vias.

9. Static characteristics

Table 6. Static characteristics^[1]

Symbol	Parameter	Conditions	Min	Typ	Max	Unit
Supplies						
V _{DDA}	analog supply voltage		2.85	3.0	3.4	V
V _{DDO}	output supply voltage	CMOS mode	1.65	1.8	3.6	V
		LVDS DDR mode	2.85	3.0	3.6	V
I _{DDA}	analog supply current	f _{clk} = 125 Msps; f _i = 70 MHz	-	210	-	mA
I _{DDO}	output supply current	CMOS mode; f _{clk} = 125 Msps; f _i = 70 MHz	-	14	-	mA
		LVDS DDR mode: f _{clk} = 125 Msps; f _i = 70 MHz	-	43	-	mA
P	power dissipation	ADC1410S125; analog supply only	-	630	-	mW
		ADC1410S105; analog supply only	-	550	-	mW
		ADC1410S080; analog supply only	-	430	-	mW
		ADC1410S065; analog supply only	-	380	-	mW
		Power-down mode	-	14	-	mW
		Sleep mode	-	40	-	mW

Clock inputs: pins CLKP and CLKM

Low-Voltage Positive Emitter-Coupled Logic (LVPECL)

V _{i(clk)dif}	differential clock input voltage	peak-to-peak	-	1.6	-	V
------------------------	----------------------------------	--------------	---	-----	---	---

SINE wave

V _{i(clk)dif}	differential clock input voltage	peak	-	±3.0	-	V
------------------------	----------------------------------	------	---	------	---	---

Low Voltage Complementary Metal Oxide Semiconductor (LVCMOS)

V _{IL}	LOW-level input voltage		-	-	0.3V _{DDA}	V
V _{IH}	HIGH-level input voltage		0.7V _{DDA}	-	-	V

Logic inputs: pins PWD and OE

V _{IL}	LOW-level input voltage		0	-	0.8	V
V _{IH}	HIGH-level input voltage		2	-	V _{DDA}	V
I _{IL}	LOW-level input current		-	55	-	μA
I _{IH}	HIGH-level input current		-	65	-	μA

Serial peripheral interface: pins CS, SDIO/ODS, SCLK/DFS

V _{IL}	LOW-level input voltage		0	-	0.3V _{DDA}	V
V _{IH}	HIGH-level input voltage		0.7V _{DDA}	-	V _{DDA}	V
I _{IL}	LOW-level input current		-10	-	+10	μA
I _{IH}	HIGH-level input current		-50	-	+50	μA
C _i	input capacitance		-	4	-	pF

Table 6. Static characteristics^[1] ...continued

Symbol	Parameter	Conditions	Min	Typ	Max	Unit
Digital outputs: CMOS mode - pins D13 to D0, OTR, DAV						
Output levels, $V_{DDO} = 3\text{ V}$						
V_{OL}	LOW-level output voltage		OGND	-	$0.2V_{DDO}$	V
V_{OH}	HIGH-level output voltage		$0.8V_{DDO}$	-	V_{DDO}	V
C_O	output capacitance	high impedance; $\overline{OE} = \text{HIGH}$	-	3	-	pF
Output levels, $V_{DDO} = 1.8\text{ V}$						
V_{OL}	LOW-level output voltage		OGND	-	$0.2V_{DDO}$	V
V_{OH}	HIGH-level output voltage		$0.8V_{DDO}$	-	V_{DDO}	V
Digital outputs, LVDS mode - pins D12_D13_P to D0_D1_P, D12_D13_M to D0_D1_M, DAVP and DAVM						
Output levels, $V_{DDO} = 3\text{ V}$ only, $R_L = 100\ \Omega$						
$V_{O(\text{offset})}$	output offset voltage	output buffer current set to 3.5 mA	-	1.2	-	V
$V_{O(\text{dif})}$	differential output voltage	output buffer current set to 3.5 mA	-	350	-	mV
C_O	output capacitance		-	3	-	pF
Analog inputs: pins INP and INM						
I_I	input current		-5	-	+5	μA
$R_{i(\text{dif})}$	differential input resistance		-	19.8	-	k Ω
$C_{i(\text{dif})}$	differential input capacitance		-	2.8	-	pF
$V_{I(\text{cm})}$	common-mode input voltage	$V_{INP} = V_{INM}$	1.1	1.5	2.5	V
B_i	input bandwidth		-	650	-	MHz
$V_{I(\text{dif})}$	differential input voltage	peak-to-peak	1	-	2	V
Common mode output voltage: pin VCM						
$V_{O(\text{cm})}$	common-mode output voltage		-	$V_{DDA} / 2$	-	V
$I_{O(\text{cm})}$	common-mode output current		-	4	-	mA
I/O reference voltage: pin VREF						
V_{VREF}	voltage on pin VREF	output	0.5	-	1	V
		input	0.5	-	1	V
Accuracy						
INL	integral non-linearity		-	± 5	-	LSB
DNL	differential non-linearity	guaranteed no missing codes	-0.95	± 0.5	+0.95	LSB
E_{offset}	offset error		-	± 2	-	mV
E_G	gain error	full-scale		± 0.5		%
Supply						
PSRR	power supply rejection ratio	200 mV (p-p) on V_{DDA} ; $f_i = \text{DC}$	-	-54	-	dB

[1] Typical values measured at $V_{DDA} = 3\text{ V}$, $V_{DDO} = 1.8\text{ V}$, $T_{\text{amb}} = 25\text{ }^\circ\text{C}$ and $C_L = 5\text{ pF}$; minimum and maximum values are across the full temperature range $T_{\text{amb}} = -40\text{ }^\circ\text{C}$ to $+85\text{ }^\circ\text{C}$ at $V_{DDA} = 3\text{ V}$, $V_{DDO} = 1.8\text{ V}$; $V_{INP} - V_{INM} = -1\text{ dBFS}$; internal reference mode; applied to CMOS and LVDS interface; unless otherwise specified.

10. Dynamic characteristics

10.1 Dynamic characteristics

Table 7. Dynamic characteristics^[1]

Symbol	Parameter	Conditions	ADC1410S065			ADC1410S080			ADC1410S105			ADC1410S125			Unit
			Min	Typ	Max	Min	Typ	Max	Min	Typ	Max	Min	Typ	Max	
Analog signal processing															
α_{2H}	second harmonic level	$f_i = 3$ MHz	-	87	-	-	87	-	-	86	-	-	88	-	dBc
		$f_i = 30$ MHz	-	86	-	-	86	-	-	86	-	-	87	-	dBc
		$f_i = 70$ MHz	-	85	-	-	85	-	-	84	-	-	85	-	dBc
		$f_i = 170$ MHz	-	82	-	-	82	-	-	81	-	-	83	-	dBc
α_{3H}	third harmonic level	$f_i = 3$ MHz	-	86	-	-	86	-	-	85	-	-	87	-	dBc
		$f_i = 30$ MHz	-	85	-	-	85	-	-	85	-	-	86	-	dBc
		$f_i = 70$ MHz	-	84	-	-	84	-	-	83	-	-	84	-	dBc
		$f_i = 170$ MHz	-	81	-	-	81	-	-	80	-	-	82	-	dBc
THD	total harmonic distortion	$f_i = 3$ MHz	-	83	-	-	83	-	-	82	-	-	84	-	dBc
		$f_i = 30$ MHz	-	82	-	-	82	-	-	82	-	-	83	-	dBc
		$f_i = 70$ MHz	-	81	-	-	81	-	-	80	-	-	81	-	dBc
		$f_i = 170$ MHz	-	78	-	-	78	-	-	77	-	-	79	-	dBc
ENOB	effective number of bits	$f_i = 3$ MHz	-	11.7	-	-	11.7	-	-	11.6	-	-	11.6	-	bits
		$f_i = 30$ MHz	-	11.6	-	-	11.5	-	-	11.5	-	-	11.5	-	bits
		$f_i = 70$ MHz	-	11.5	-	-	11.5	-	-	11.4	-	-	11.4	-	bits
		$f_i = 170$ MHz	-	11.4	-	-	11.4	-	-	11.3	-	-	11.3	-	bits
SNR	signal-to-noise ratio	$f_i = 3$ MHz	-	72.1	-	-	72.0	-	-	71.8	-	-	71.4	-	dBFS
		$f_i = 30$ MHz	-	71.3	-	-	71.2	-	-	71.8	-	-	71.4	-	dBFS
		$f_i = 70$ MHz	-	70.7	-	-	70.7	-	-	70.6	-	-	70.5	-	dBFS
		$f_i = 170$ MHz	-	70.2	-	-	70.1	-	-	70.0	-	-	69.9	-	dBFS
SFDR	spurious-free dynamic range	$f_i = 3$ MHz	-	86	-	-	86	-	-	85	-	-	87	-	dBc
		$f_i = 30$ MHz	-	85	-	-	85	-	-	85	-	-	86	-	dBc
		$f_i = 70$ MHz	-	84	-	-	84	-	-	83	-	-	84	-	dBc
		$f_i = 170$ MHz	-	81	-	-	81	-	-	80	-	-	82	-	dBc

Table 7. Dynamic characteristics^[1] ...continued

Symbol	Parameter	Conditions	ADC1410S065			ADC1410S080			ADC1410S105			ADC1410S125			Unit
			Min	Typ	Max	Min	Typ	Max	Min	Typ	Max	Min	Typ	Max	
IMD	Intermodulation distortion	$f_{i1} = 1.5$ MHz; $f_{i2} = 4.5$ MHz	-	89	-	-	89	-	-	88	-	-	89	-	dBc
		$f_{i1} = 28.5$ MHz; $f_{i2} = 31.5$ MHz	-	88	-	-	88	-	-	88	-	-	88	-	dBc
		$f_{i1} = 68.5$ MHz; $f_{i2} = 71.5$ MHz	-	87	-	-	87	-	-	86	-	-	86	-	dBc
		$f_{i1} = 168.5$ MHz; $f_{i2} = 171.5$ MHz	-	84	-	-	85	-	-	83	-	-	84	-	dBc

[1] Typical values measured at $V_{DDA} = 3$ V, $V_{DDO} = 1.8$ V, $T_{amb} = 25$ °C and $C_L = 5$ pF; minimum and maximum values are across the full temperature range $T_{amb} = -40$ °C to $+85$ °C at $V_{DDA} = 3$ V, $V_{DDO} = 1.8$ V; $V_{INP} - V_{INM} = -1$ dBFS; internal reference mode; applied to CMOS and LVDS interface; unless otherwise specified.

10.2 Clock and digital output timing

Table 8. Clock input and digital output timing characteristics^[1]

Symbol	Parameter	Conditions	ADC1410S065			ADC1410S080			ADC1410S105			ADC1410S125			Unit
			Min	Typ	Max	Min	Typ	Max	Min	Typ	Max	Min	Typ	Max	
Clock timing input: pins CLKP and CLKM															
f_{clk}	clock frequency		40	-	65	60	-	80	75	-	105	100	-	125	MHz
$t_{lat(data)}$	data latency time		-	13.5	-	-	13.5	-	-	13.5	-	-	13.5	-	clock cycles
δ_{clk}	clock duty cycle	DCS_EN = logic 1	30	50	70	30	50	70	30	50	70	30	50	70	%
		DCS_EN = logic 0	45	50	55	45	50	55	45	50	55	45	50	55	%
$t_{d(s)}$	sampling delay time		-	0.8	-	-	0.8	-	-	0.8	-	-	0.8	-	ns
t_{wake}	wake-up time		-	76	-	-	76	-	-	76	-	-	76	-	μ s
CMOS Mode timing output: pins D13 to D0 and DAV															
t_{pD}	propagation delay	DATA	13.6	14.9	16.4	11.9	12.9	14.4	8.0	10.8	12.4	8.2	9.7	11.3	ns
		DAV	-	4.2	-	-	3.6	-	-	3.3	-	-	3.4	-	ns
t_{su}	set-up time		-	12.5	-	-	9.8	-	-	6.8	-	-	5.6	-	ns
t_h	hold time		-	3.4	-	-	3.3	-	-	3.1	-	-	2.8	-	ns

Table 8. Clock input and digital output timing characteristics^[1] ...continued

Symbol	Parameter	Conditions	ADC1410S065			ADC1410S080			ADC1410S105			ADC1410S125			Unit	
			Min	Typ	Max	Min	Typ	Max	Min	Typ	Max	Min	Typ	Max		
t _r	rise time	DATA	[2]	0.39	-	2.4	0.39	-	2.4	0.39	-	2.4	0.39	-	2.4	ns
		DAV		0.26	-	2.4	0.26	-	2.4	0.26	-	2.4	0.26	-	2.4	ns
t _f	fall time	DATA	[2]	0.19	-	2.4	0.19	-	2.4	0.19	-	2.4	0.19	-	2.4	ns
LVDS DDR mode timing output: pins D12_D13_P to D0_D1_P, D12_D13_M to D0_D1_M, DAVP and DAVM																
t _{PD}	propagation delay	DATA		3.3	5.1	7.6	2.9	4.6	7.1	2.5	4.2	6.8	2.2	4.0	6.6	ns
		DAV		-	2.8	-	-	2.5	-	-	2.3	-	-	2.2	-	ns
t _{su}	set-up time			-	5.4	-	-	4.1	-	-	2.6	-	-	1.9	-	ns
t _h	hold time			-	2.2	-	-	2.0	-	-	1.8	-	-	1.7	-	ns
t _r	rise time	DATA	[3]	0.5	-	5	0.5	-	5	0.5	-	5	0.5	-	5	ns
		DAV		0.18	-	2.4	0.18	-	2.4	0.18	-	2.4	0.18	-	2.4	ns
t _f	fall time	DATA	[3]	0.15	-	1.6	0.15	-	1.6	0.15	-	1.6	0.15	-	1.6	ns

[1] Typical values measured at V_{DDA} = 3 V, V_{DDO} = 1.8 V, T_{amb} = 25 °C and C_L = 5 pF; minimum and maximum values are across the full temperature range T_{amb} = -40 °C to +85 °C at V_{DDA} = 3 V, V_{DDO} = 1.8 V; V_{INP} - V_{INM} = -1 dBFS; internal reference mode; applied to CMOS and LVDS interface; unless otherwise specified.

[2] Measured between 20 % to 80 % of V_{DDO}.

[3] Rise time measured from -50 mV to +50 mV; fall time measured from +50 mV to -50 mV.

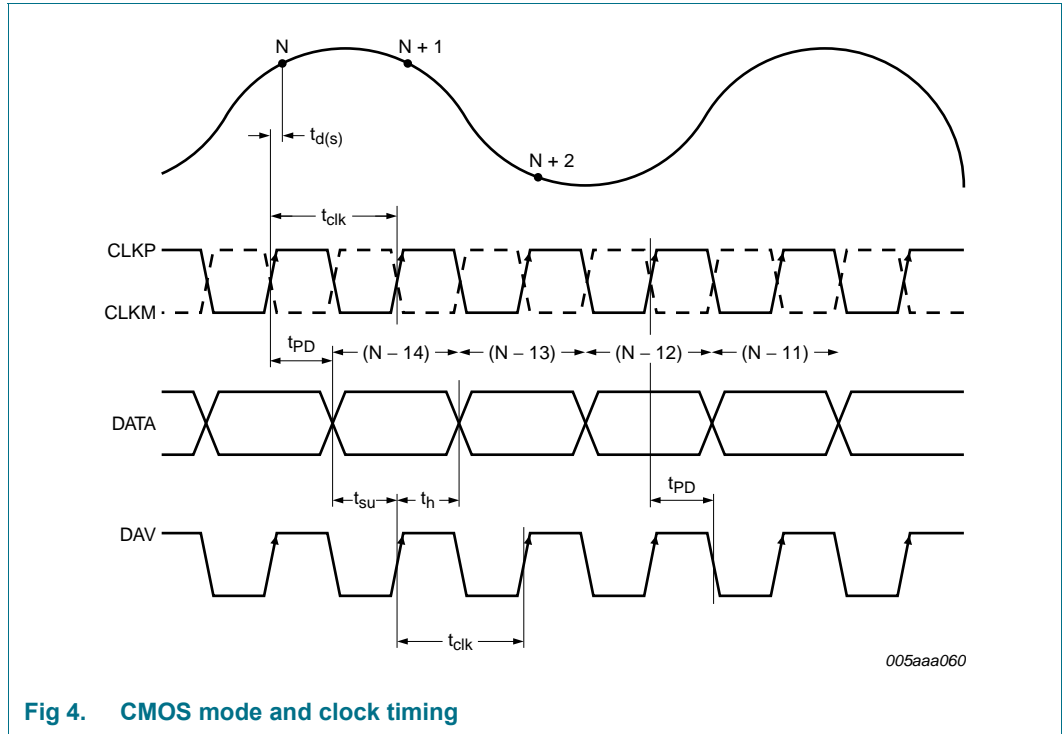

Fig 4. CMOS mode and clock timing

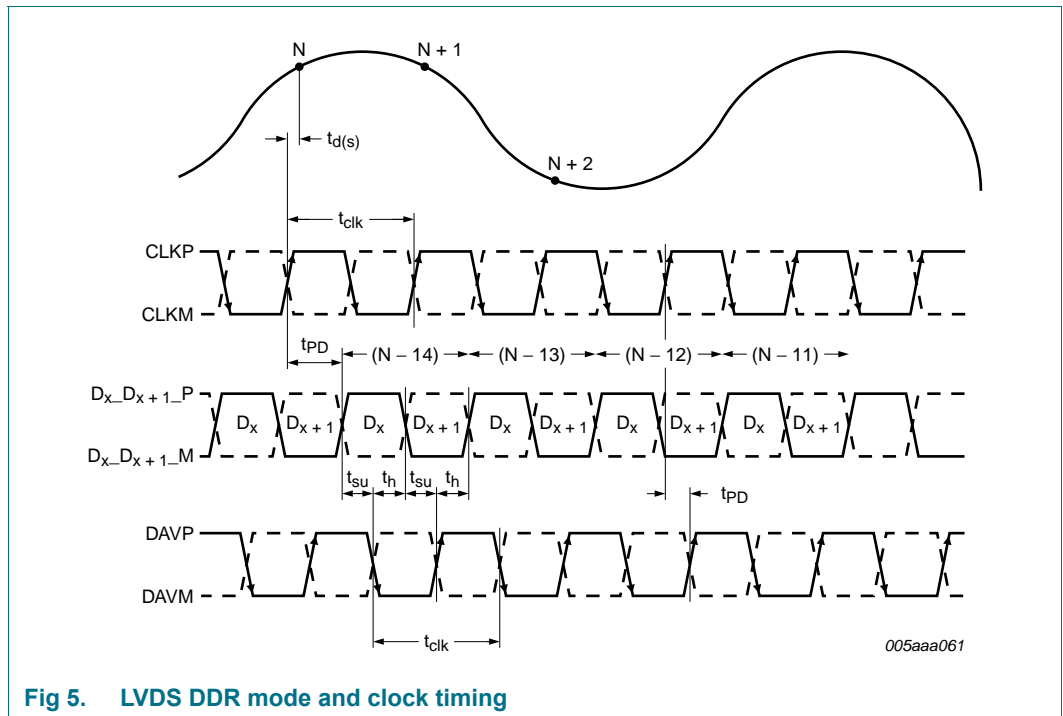

Fig 5. LVDS DDR mode and clock timing

10.3 SPI timings

Table 9. SPI timings characteristics^[1]

Symbol	Parameter	Conditions	Min	Typ	Max	Unit
$t_{w(SCLK)}$	SCLK pulse width		-	40	-	ns
$t_{w(SCLKH)}$	SCLK HIGH pulse width		-	16	-	ns
$t_{w(SCLKL)}$	SCLK LOW pulse width		-	16	-	ns
t_{su}	set-up time	data to SCLK HIGH	-	5	-	ns
		\overline{CS} to SCLK HIGH	-	5	-	ns
t_h	hold time	data to SCLK HIGH	-	2	-	ns
		\overline{CS} to SCLK HIGH	-	2	-	ns
$f_{clk(max)}$	maximum clock frequency		-	25	-	MHz

[1] Typical values measured at $V_{DDA} = 3\text{ V}$, $V_{DDO} = 1.8\text{ V}$, $T_{amb} = 25\text{ }^\circ\text{C}$ and $C_L = 5\text{ pF}$; minimum and maximum values are across the full temperature range $T_{amb} = -40\text{ }^\circ\text{C}$ to $+85\text{ }^\circ\text{C}$ at $V_{DDA} = 3\text{ V}$, $V_{DDO} = 1.8\text{ V}$.

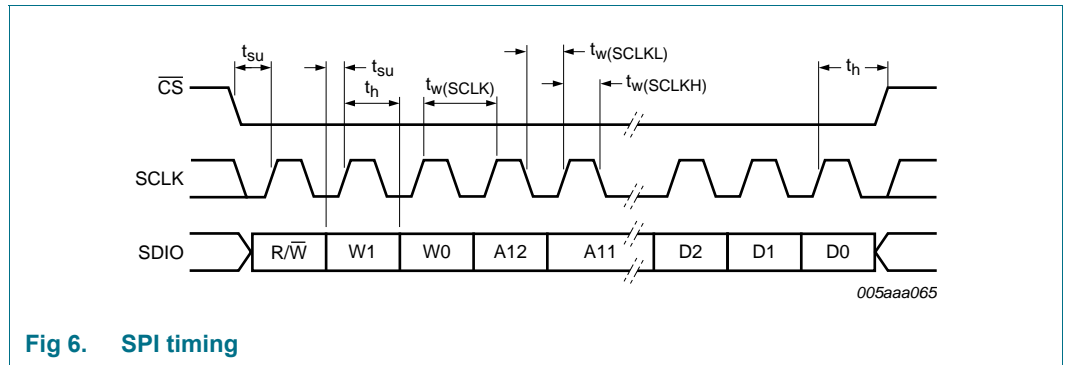

Fig 6. SPI timing

10.4 Typical characteristics

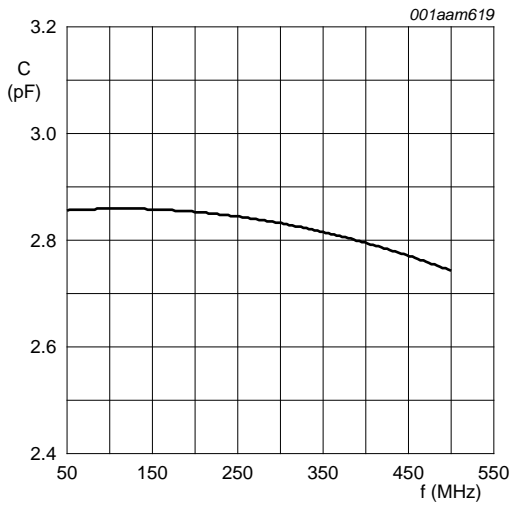

Fig 7. Capacitance as a function of frequency

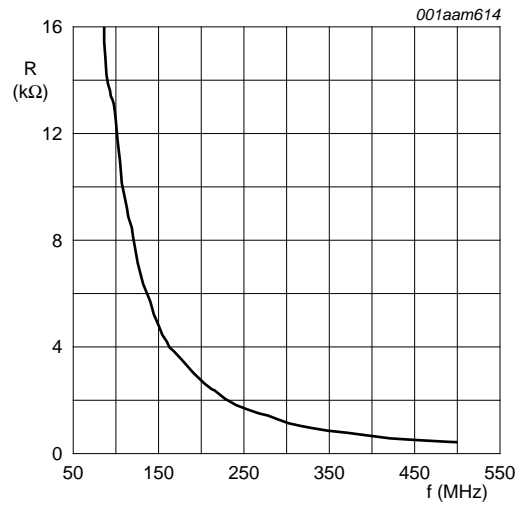
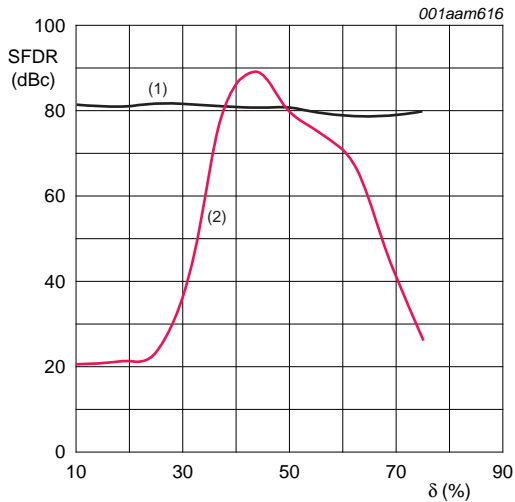
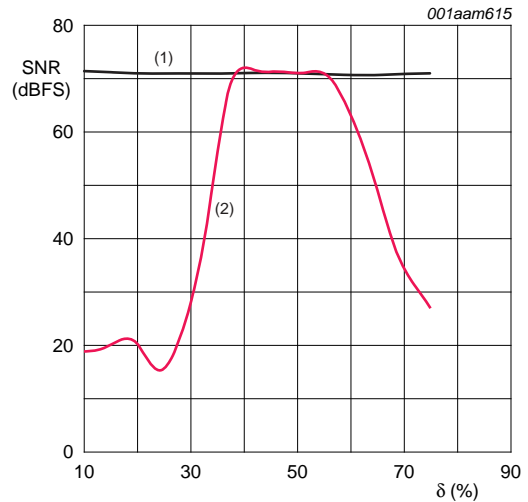

Fig 8. Resistance as a function of frequency



$T = 25\text{ }^{\circ}\text{C}; V_{DD} = 3\text{ V}; f_i = 170\text{ MHz}; f_s = 125\text{ Msps}$
 (1) DCS on
 (2) DCS off

Fig 9. SFDR as a function of duty cycle (δ)



$T = 25\text{ }^{\circ}\text{C}; V_{DD} = 3\text{ V}; f_i = 170\text{ MHz}; f_s = 125\text{ Msps}$
 (1) DCS on
 (2) DCS off

Fig 10. SNR as a function of duty cycle (δ)

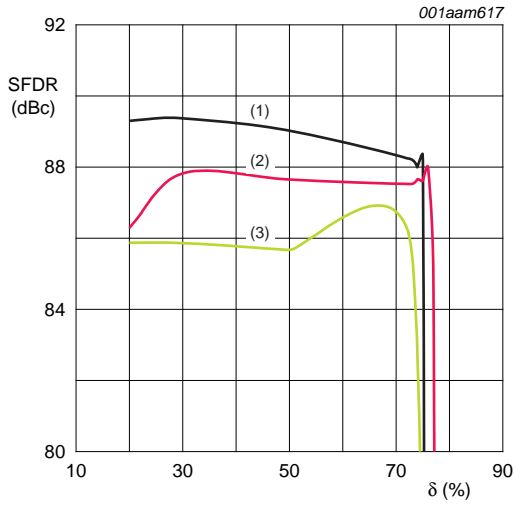

- (1) $T_{amb} = -40\text{ }^{\circ}\text{C}$ /typical supply voltages
- (2) $T_{amb} = +25\text{ }^{\circ}\text{C}$ /typical supply voltages
- (3) $T_{amb} = +90\text{ }^{\circ}\text{C}$ /typical supply voltages

Fig 11. SFDR as a function of duty cycle (δ)

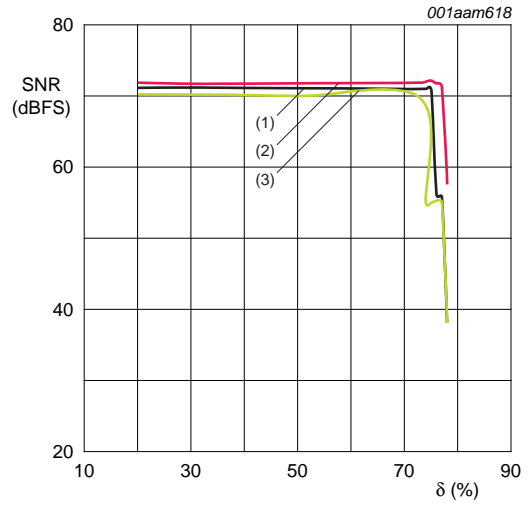

- (1) $T_{amb} = -40\text{ }^{\circ}\text{C}$ /typical supply voltages
- (2) $T_{amb} = +25\text{ }^{\circ}\text{C}$ /typical supply voltages
- (3) $T_{amb} = +90\text{ }^{\circ}\text{C}$ /typical supply voltages

Fig 12. SNR as a function of duty cycle (δ)

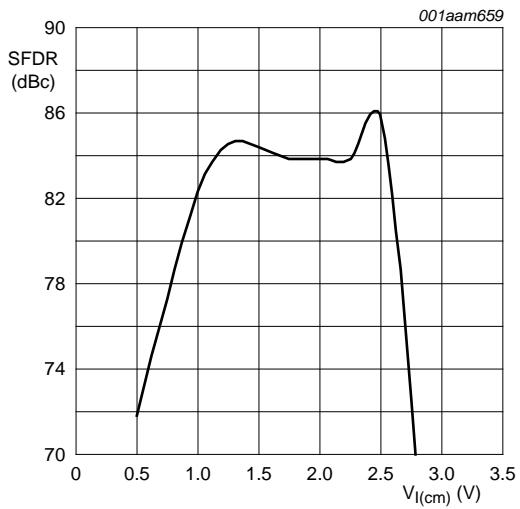

Fig 13. SFDR as a function of common-mode input voltage ($V_{I(cm)}$)

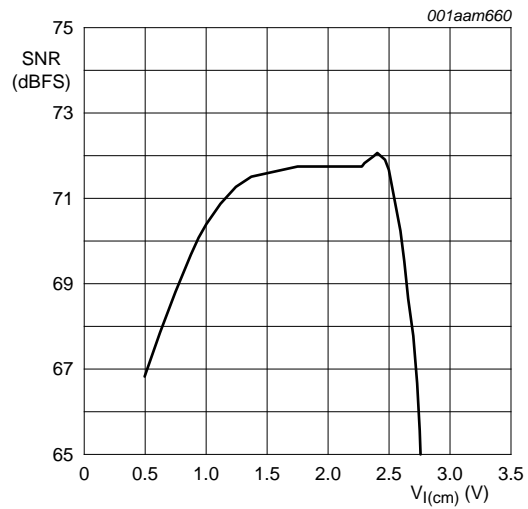

Fig 14. SNR as a function of common-mode input voltage ($V_{I(cm)}$)

10.4.1 ADC1410S080

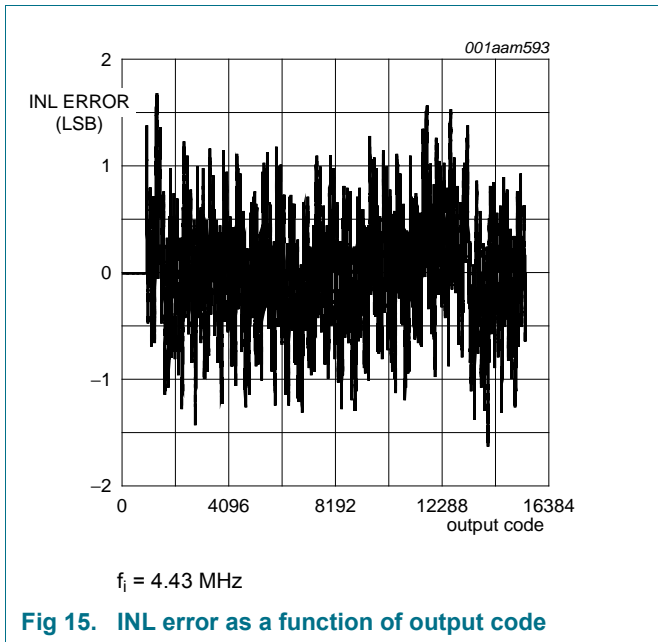

Fig 15. INL error as a function of output code

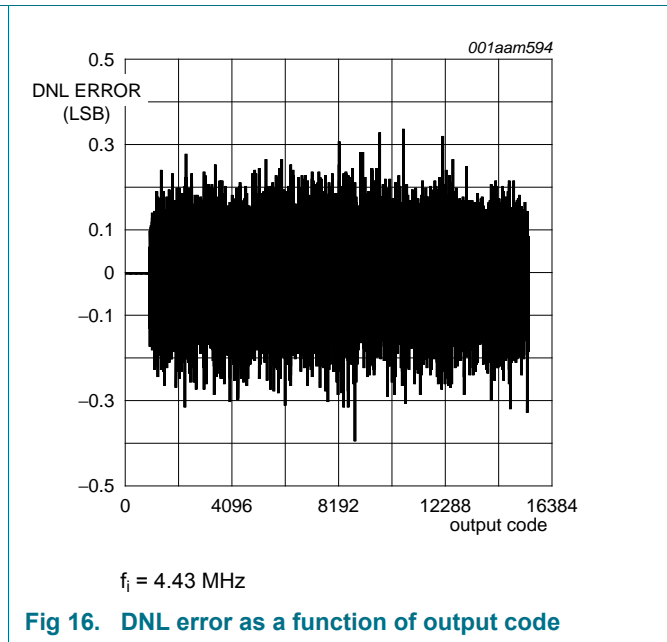

Fig 16. DNL error as a function of output code

10.4.2 ADC1410S125

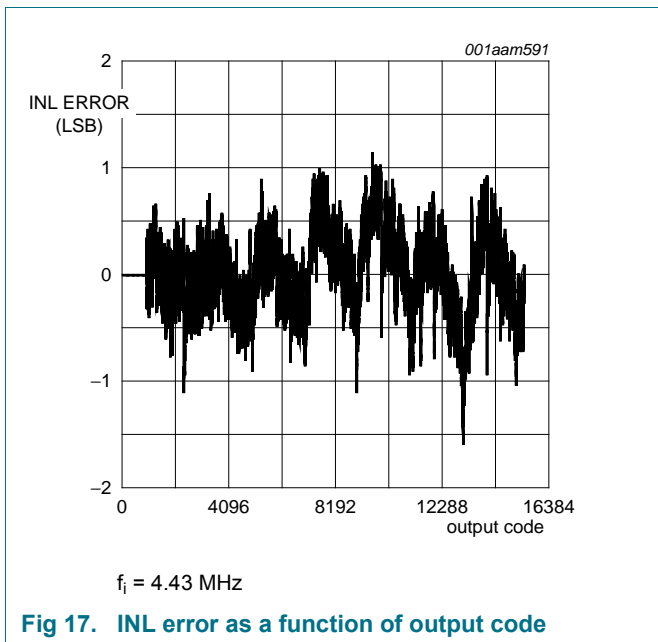

Fig 17. INL error as a function of output code

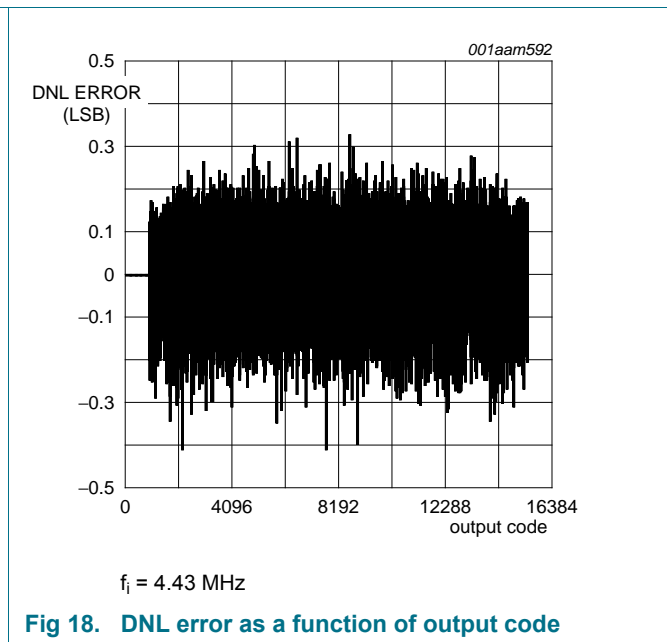

Fig 18. DNL error as a function of output code

11. Application information

11.1 Device control

The ADC1410S can be controlled via SPI or directly via the I/O pins (Pin control mode).

11.1.1 SPI and PIN control modes

The device enters PIN control mode at power-up, and remains in this mode as long as pin \overline{CS} is held HIGH. In PIN control mode, the SPI pins SDIO, \overline{CS} and SCLK are used as static control pins.

SPI control mode is enabled by forcing pin \overline{CS} LOW. Once SPI control mode has been enabled, the device remains in this mode. The transition from PIN control mode to SPI control mode is illustrated in Figure 19.

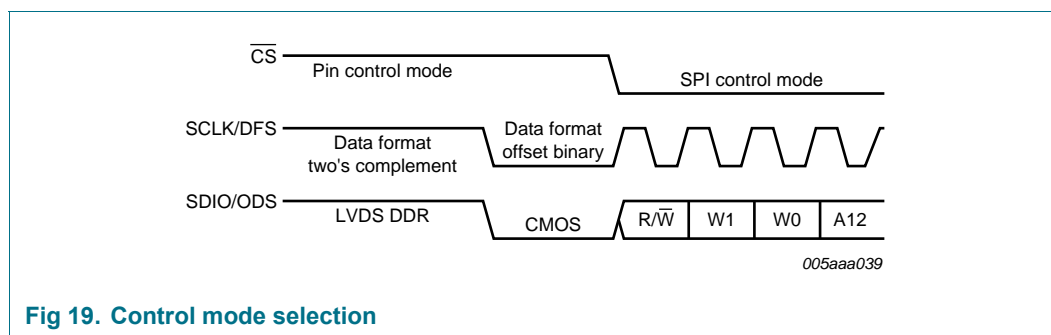

Fig 19. Control mode selection

When the device enters SPI control mode, the output data standard and data format are determined by the level on pin SDIO when a transition is triggered by a falling edge on \overline{CS} .

11.1.2 Operating mode selection

The active ADC1410S operating mode (Power-up, Power-down or Sleep) can be selected via the SPI interface (see Table 20) or by using pins PWD and \overline{OE} in Pin control mode (see Table 10).

Table 10. Operating mode selection via pin PWD and \overline{OE}

Pin PWD	Pin \overline{OE}	Operating mode	Output high-Z
LOW	LOW	Power-up	no
LOW	HIGH	Power-up	yes
HIGH	LOW	Sleep	yes
HIGH	HIGH	Power-down	yes

11.1.3 Selecting the output data standard

The output data standard (CMOS or LVDS DDR) can be selected via the SPI interface (see Table 23) or by using pin ODS in Pin control mode. LVDS DDR is selected when ODS is HIGH, otherwise CMOS is selected.

11.1.4 Selecting the output data format

The output data format can be selected via the SPI interface (offset binary, two's complement or gray code; see Table 23) or using pin DFS in Pin control mode (offset binary or two's complement). Offset binary is selected when DFS is LOW. When DFS is HIGH, two's complement is selected.

11.2 Analog inputs

11.2.1 Input stage

The analog input of the ADC1410S supports a differential or a single-ended input drive. Optimal performance is achieved using differential inputs with the common-mode input voltage ($V_{I(cm)}$) on pins INP and INM set to $0.5V_{DDA}$.

The full-scale analog input voltage range is configurable between 1 V (p-p) and 2 V (p-p) via a programmable internal reference (see Section 11.3 and Table 22).

The equivalent circuit of the sample and hold input stage, including Electrostatic Discharge (ESD) protection and circuit and package parasitics, is shown in Figure 20.

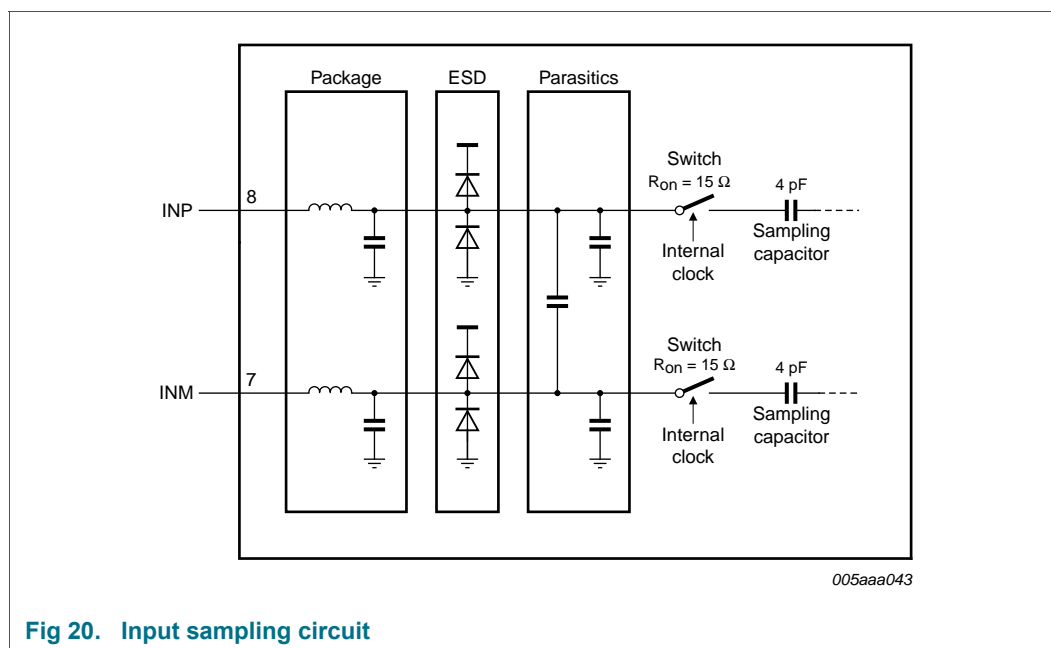

Fig 20. Input sampling circuit

The sample phase occurs when the internal clock (derived from the clock signal on pin CLKP/CLKM) is HIGH. The voltage is then held on the sampling capacitors. When the clock signal goes LOW, the stage enters the hold phase and the voltage information is transmitted to the ADC core.

11.2.2 Anti-kickback circuitry

Anti-kickback circuitry (R-C filter in Figure 21) is needed to counteract the effects of a charge injection generated by the sampling capacitance.

The RC filter is also used to filter noise from the signal before it reaches the sampling stage. The value of the capacitor should be chosen to maximize noise attenuation without degrading the settling time excessively.

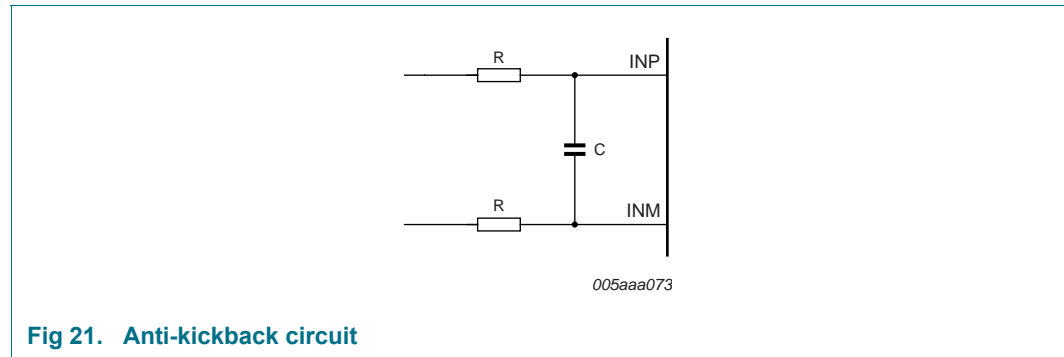

Fig 21. Anti-kickback circuit

The component values are determined by the input frequency and should be selected so as not to affect the input bandwidth.

Table 11. RC coupling versus input frequency, typical values

Input frequency	Resistance	Capacitance
3 MHz	25 Ω	12 pF
70 MHz	12 Ω	8 pF
170 MHz	12 Ω	8 pF

11.2.3 Transformer

The configuration of the transformer circuit is determined by the input frequency. The configuration shown in Figure 22 would be suitable for a baseband application.

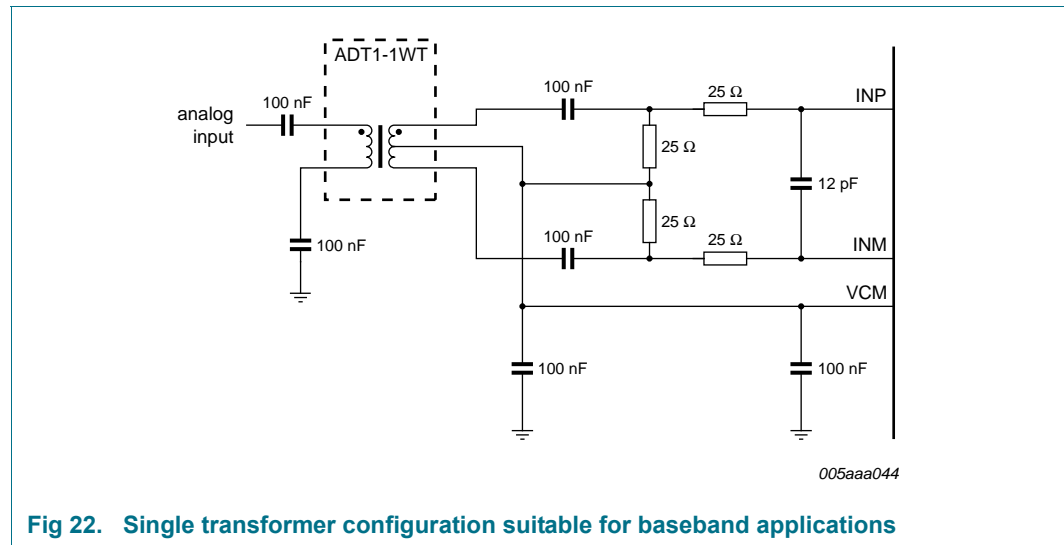
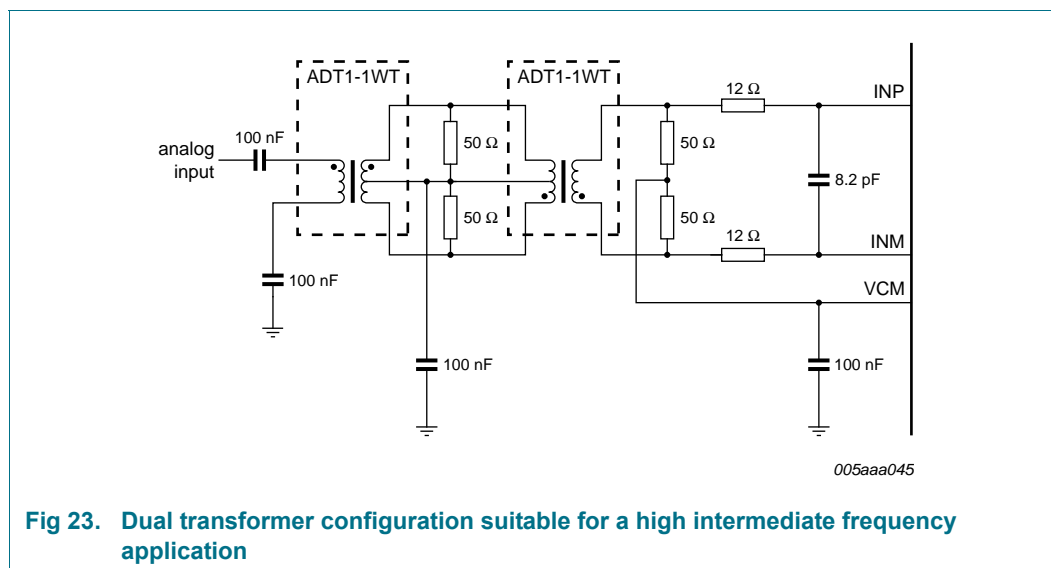

Fig 22. Single transformer configuration suitable for baseband applications

The configuration shown in Figure 23 is recommended for high frequency applications. In both cases, the choice of transformer is a compromise between cost and performance.



11.3 System reference and power management

11.3.1 Internal/external references

The ADC1410S has a stable and accurate built-in internal reference voltage to adjust the ADC full-scale. This reference voltage can be set internally via SPI or with pins VREF and SENSE (programmable in 1 dB steps between 0 dB and -6 dB via control bits INTREF[2:0] when bit INTREF_EN = logic 1; see Table 22). See Figure 25 to Figure 28. The equivalent reference circuit is shown in Figure 24. An external reference is also possible by providing a voltage on pin VREF as described in Figure 27.

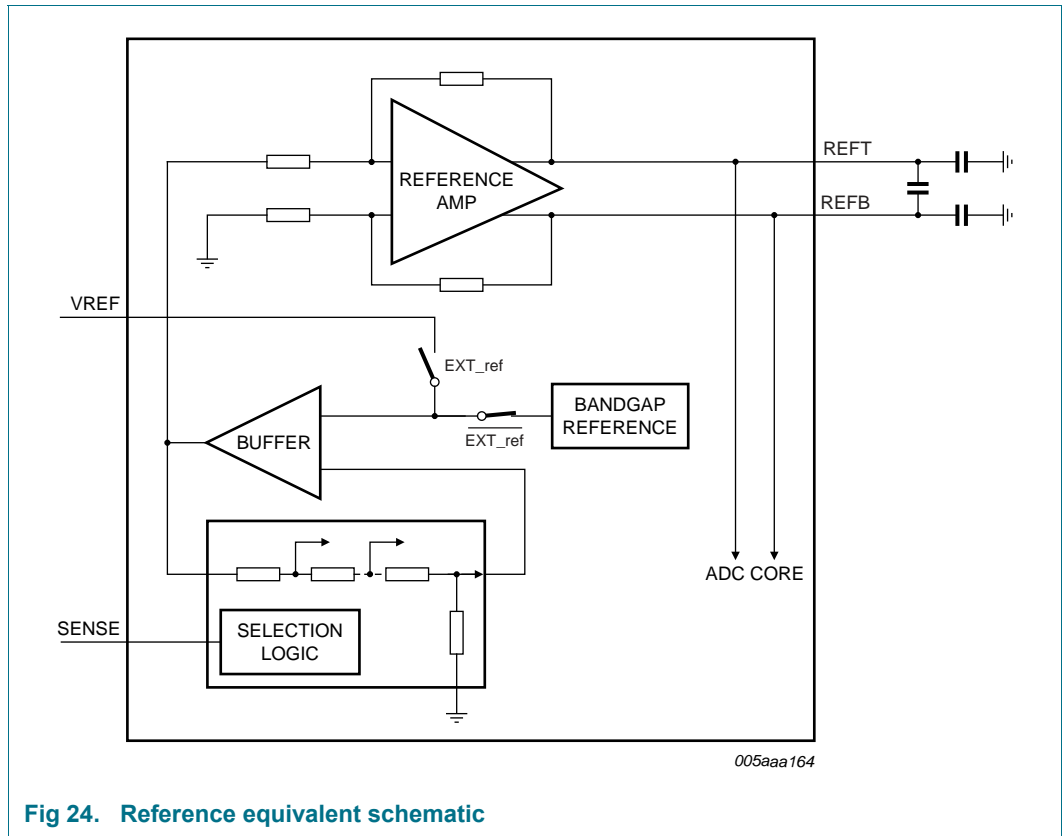

Fig 24. Reference equivalent schematic

If bit INTREF_EN is set to logic 0, the reference voltage is determined either internally or externally as detailed in Table 12.

Table 12. Reference selection

Selection	SPI bit INTREF_EN	SENSE pin	VREF pin	Full-scale (p-p)
internal (Figure 25)	0	AGND	330 pF capacitor to AGND	2 V
internal (Figure 26)	0	pin VREF connected to pin SENSE and via a 330 pF capacitor to AGND		1 V
external (Figure 27)	0	V _D DA	external voltage between 0.5 V and 1 V ^[1]	1 V to 2 V
internal via SPI (Figure 28)	1	pin VREF connected to pin SENSE and via 330 pF capacitor to AGND		1 V to 2 V

[1] The voltage on pin VREF is doubled internally to generate the internal reference voltage.

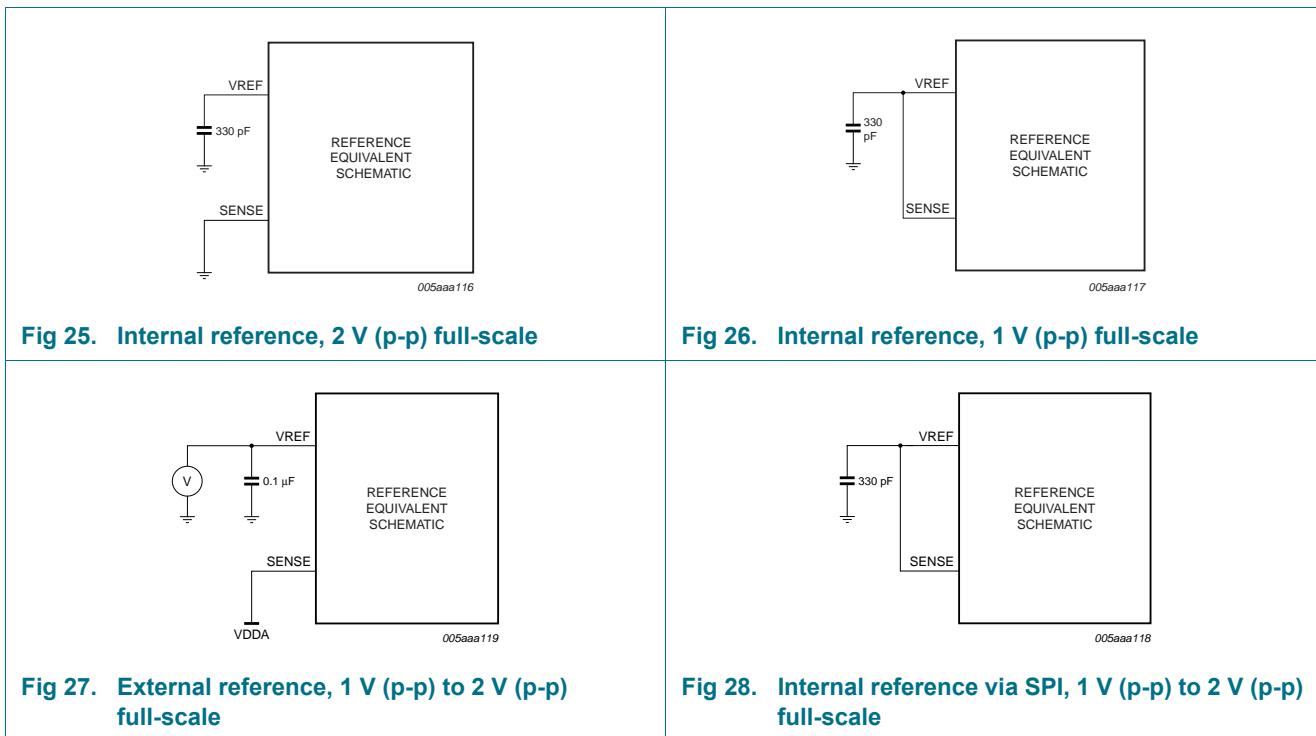

Figure 25 to Figure 28 illustrate how to connect the SENSE and VREF pins to select the required reference voltage source.

11.3.2 Programmable full-scale

The full-scale is programmable between 1 V (peak-to-peak) to 2 V (peak-to-peak) (see Table 13).

Table 13. Reference SPI gain control

INTREF[2:0]	Full-scale (V (p-p))
000	2
001	1.78
010	1.59
011	1.42
100	1.26
101	1.12
110	1
111	x

11.3.3 Common-mode output voltage ($V_{O(cm)}$)

A 0.1 μ F filter capacitor should be connected between pin VCM and ground to ensure a low-noise common-mode output voltage. When AC-coupled, pin VCM can then be used to set the common-mode reference for the analog inputs, for instance via a transformer middle point.

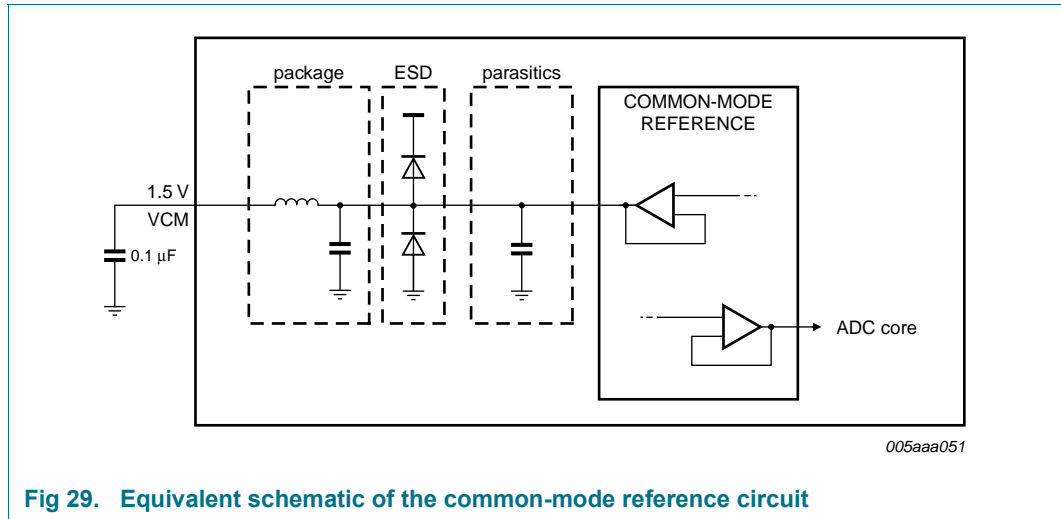

Fig 29. Equivalent schematic of the common-mode reference circuit

11.3.4 Biasing

The common-mode input voltage ($V_{I(cm)}$) on pins INP and INM should be set externally to $0.5V_{DDA}$ for optimal performance and should always be between 1.1 V and 2.5 V (see Table 6).

11.4 Clock input

11.4.1 Drive modes

The ADC1410S can be driven differentially (LVPECL). It can also be driven by a single-ended Low Voltage Complementary Metal Oxide Semiconductor (LVCMOS) signal connected to pin CLKP (pin CLKM should be connected to ground via a capacitor) or pin CLKM (pin CLKP should be connected to ground via a capacitor).

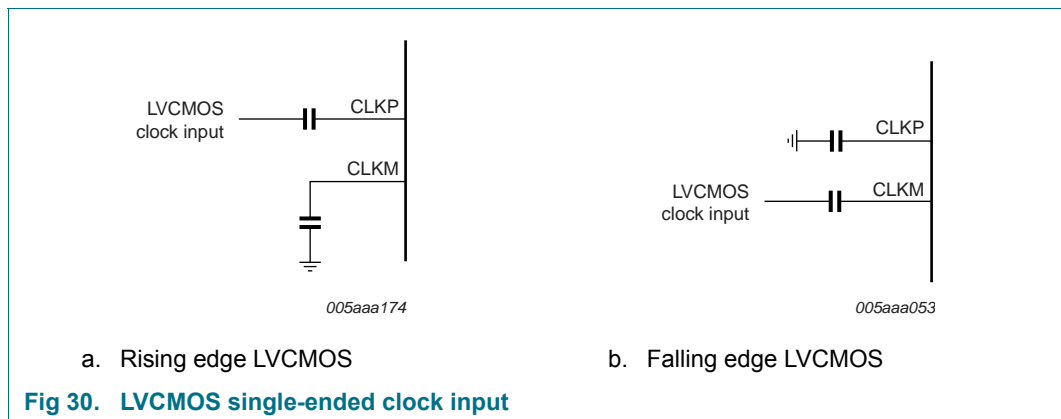
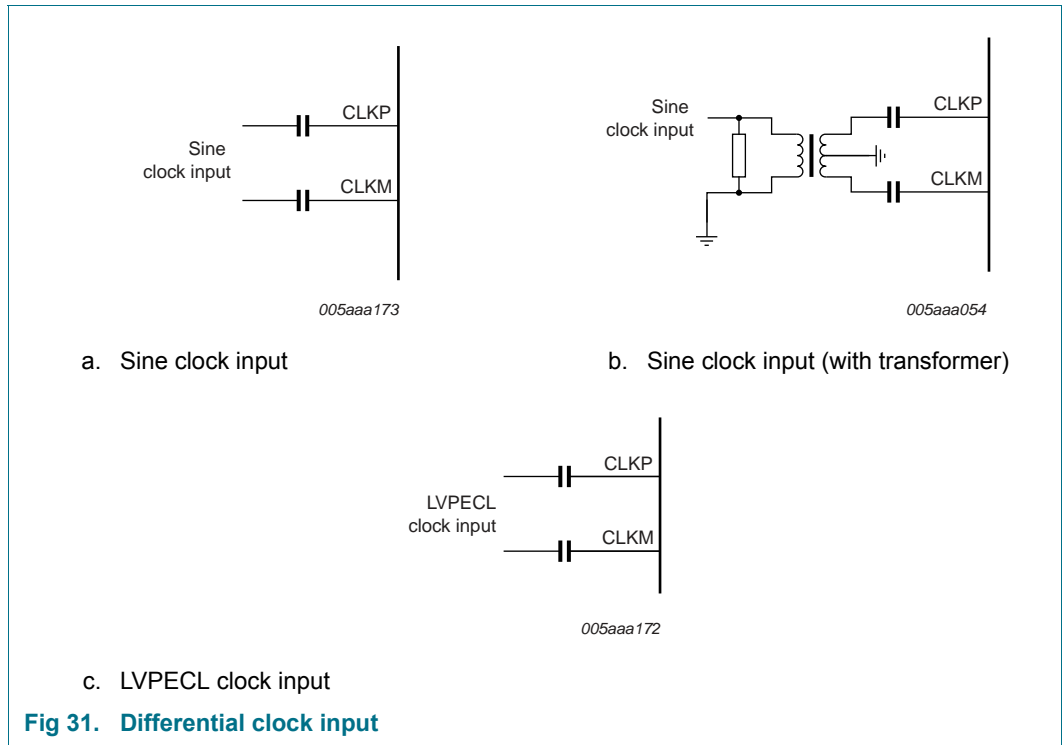
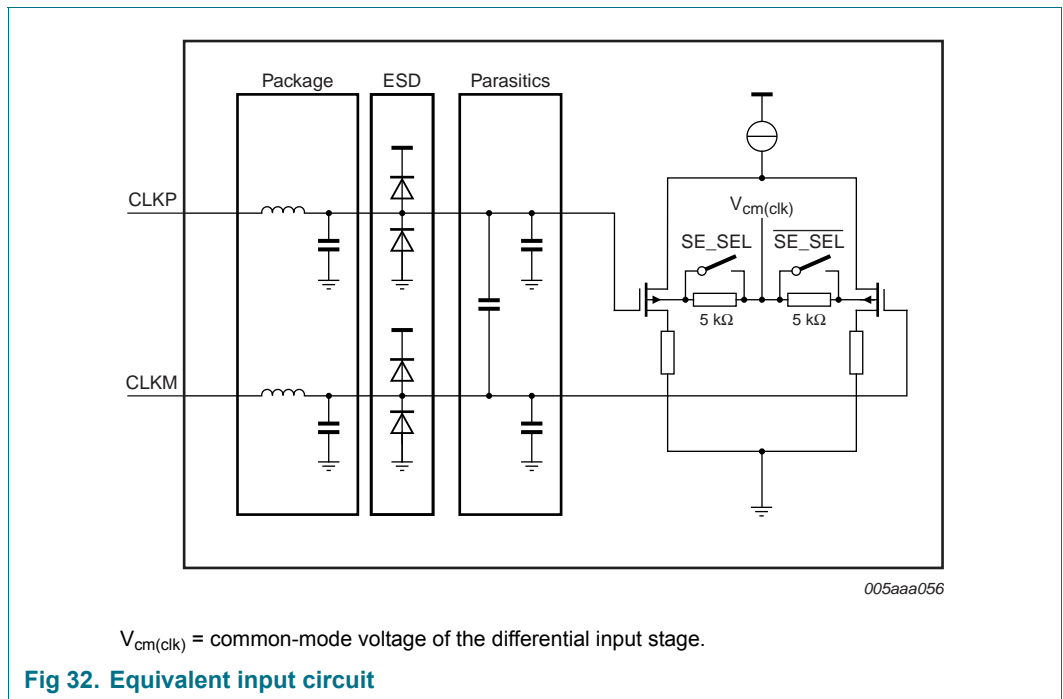

Fig 30. LVCMOS single-ended clock input



11.4.2 Equivalent input circuit

The equivalent circuit of the input clock buffer is shown in Figure 32. The common-mode voltage of the differential input stage is set via internal 5 kΩ resistors.



Single-ended or differential clock inputs can be selected via the SPI interface (see Table 21). If single-ended is enabled, the input pin (CLKM or CLKP) is selected via control bit SE_SEL.

If single-ended is implemented without setting bit SE_SEL to the appropriate value, the unused pin should be connected to ground via a capacitor.

11.4.3 Duty cycle stabilizer

The duty cycle stabilizer can improve the overall performance of the ADC by compensating the duty cycle of the input clock signal. When the duty cycle stabilizer is active (bit DCS_EN = logic 1; see Table 21), the circuit can handle signals with duty cycles of between 30 % and 70 % (typical). When the duty cycle stabilizer is disabled (DCS_EN = logic 0), the input clock signal should have a duty cycle of between 45 % and 55 %.

11.4.4 Clock input divider

The ADC1410S contains an input clock divider that divides the incoming clock by a factor of 2 (when bit CLKDIV = logic 1; see Table 21). This feature allows the user to deliver a higher clock frequency with better jitter performance, leading to a better SNR result once acquisition has been performed.

11.5 Digital outputs

11.5.1 Digital output buffers: CMOS mode

The digital output buffers can be configured as CMOS by setting bit LVDS_CMOS to logic 0 (see Table 23).

Each digital output has a dedicated output buffer. The equivalent circuit of the CMOS digital output buffer is shown in Figure 33. The buffer is powered by a separate power supply, pins OGND and VDDO, to ensure 1.8 V to 3.3 V compatibility and is isolated from the ADC core. Each buffer can be loaded by a maximum of 10 pF.

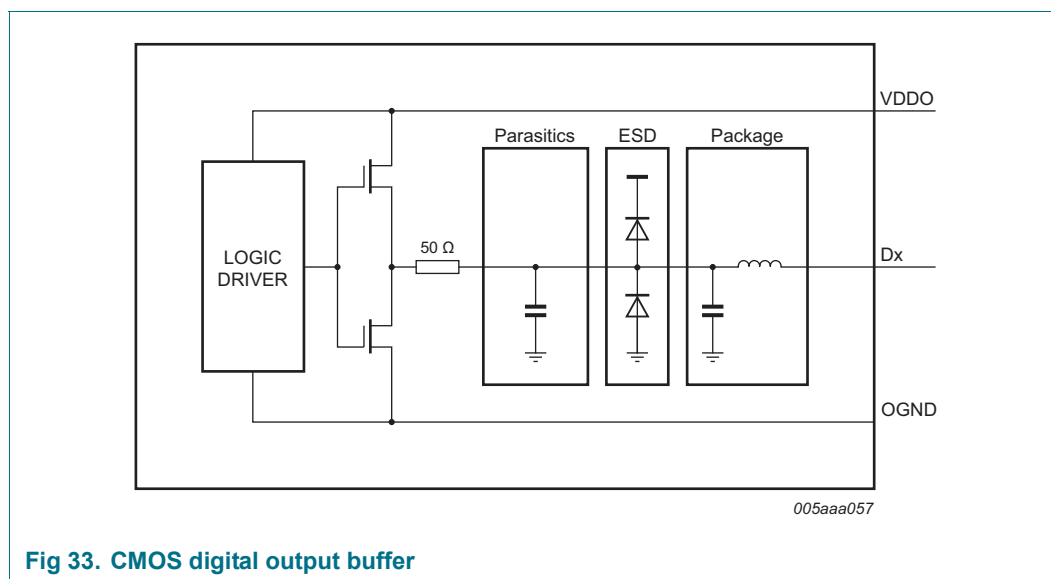

The output resistance is $50\ \Omega$ and is the combination of an internal resistor and the equivalent output resistance of the buffer. There is no need for an external damping resistor. The drive strength of both data and DAV buffers can be programmed via the SPI in order to adjust the rise and fall times of the output digital signals (see Table 30).

11.5.2 Digital output buffers: LVDS DDR mode

The digital output buffers can be configured as LVDS DDR by setting bit LVDS_CMOS to logic 1 (see Table 23).

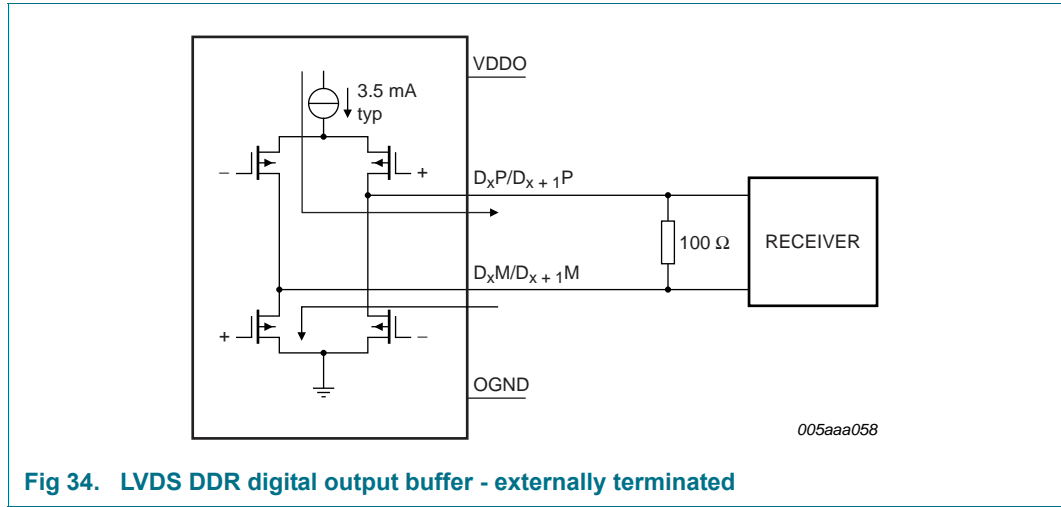

Fig 34. LVDS DDR digital output buffer - externally terminated

Each output should be terminated externally with a $100\ \Omega$ resistor (typical) at the receiver side (Figure 34) or internally via SPI control bits LVDS_INT_TER[2:0] (see Figure 35 and Table 32).

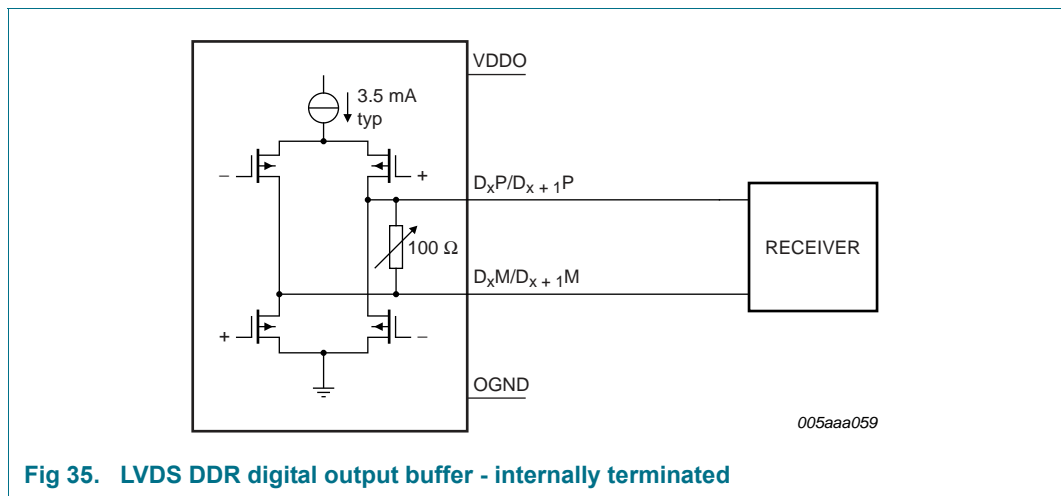

Fig 35. LVDS DDR digital output buffer - internally terminated

The default LVDS DDR output buffer current is set to 3.5 mA. It can be programmed via the SPI (bits DAVI[1:0] and DATAI[1:0]; see Table 31) in order to adjust the output logic voltage levels.

Table 14. LVDS DDR output register 2

LVDS_INT_TER[2:0]	Resistor value (Ω)
000	no internal termination
001	300
010	180
011	110
100	150
101	100
110	81
111	60

11.5.3 Data Valid (DAV) output clock

A data valid output clock signal (DAV) can be used to capture the data delivered by the ADC1410S. Detailed timing diagrams for CMOS and LVDS DDR modes are shown in Figure 4 and Figure 5 respectively.

11.5.4 Out-of-Range (OTR)

An out-of-range signal is provided on pin OTR. The latency of OTR is fourteen clock cycles. The OTR response can be speeded up by enabling Fast OTR (bit FASTOTR = logic 1; see Table 29). In this mode, the latency of OTR is reduced to only four clock cycles. The Fast OTR detection threshold (below full-scale) can be programmed via bits FASTOTR_DET[2:0].

Table 15. Fast OTR register

FASTOTR_DET[2:0]	Detection level (dB)
000	-20.56
001	-16.12
010	-11.02
011	-7.82
100	-5.49
101	-3.66
110	-2.14
111	-0.86

11.5.5 Digital offset

By default, the ADC1410S delivers output code that corresponds to the analog input. However it is possible to add a digital offset to the output code via the SPI (bits DIG_OFFSET[5:0]; see Table 25).

11.5.6 Test patterns

For test purposes, the ADC1410S can be configured to transmit one of a number of predefined test patterns (via bits TESTPAT_SEL[2:0]; see Table 26). A custom test pattern can be defined by the user (TESTPAT_USER[13:0]; see Table 27 and Table 28) and is selected when TESTPAT_SEL[2:0] = 101. The selected test pattern is transmitted regardless of the analog input.

11.5.7 Output codes versus input voltage

Table 16. Output codes

$V_{INP} - V_{INM}$	Offset binary	Two's complement	OTR pin
< -1	00 0000 0000 0000	10 0000 0000 0000	1
-1	00 0000 0000 0000	10 0000 0000 0000	0
-0.9998779	00 0000 0000 0001	10 0000 0000 0001	0
-0.9997559	00 0000 0000 0010	10 0000 0000 0010	0
-0.9996338	00 0000 0000 0011	10 0000 0000 0011	0
-0.9995117	00 0000 0000 0100	10 0000 0000 0100	0
....	0
-0.0002441	01 1111 1111 1110	11 1111 1111 1110	0
-0.0001221	01 1111 1111 1111	11 1111 1111 1111	0
0	10 0000 0000 0000	00 0000 0000 0000	0
+0.0001221	10 0000 0000 0001	00 0000 0000 0001	0
+0.0002441	10 0000 0000 0010	00 0000 0000 0010	0
....	0
+0.9995117	11 1111 1111 1011	01 1111 1111 1011	0
+0.9996338	11 1111 1111 1100	01 1111 1111 1100	0
+0.9997559	11 1111 1111 1101	01 1111 1111 1101	0
+0.9998779	11 1111 1111 1110	01 1111 1111 1110	0
+1	11 1111 1111 1111	01 1111 1111 1111	0
> +1	11 1111 1111 1111	01 1111 1111 1111	1

11.6 Serial peripheral interface

11.6.1 Register description

The ADC1410S serial interface is a synchronous serial communications port that allows easy interfacing with many commonly-used microprocessors. It provides access to the registers that control the operation of the chip.

This interface is configured as a 3-wire type (SDIO as bidirectional pin).

Pin SCLK is the serial clock input and \overline{CS} is the chip select pin.

Each read/write operation is initiated by a LOW level on pin \overline{CS} . A minimum of three bytes is transmitted (two instruction bytes and at least one data byte). The number of data bytes is determined by the value of bits W1 and W2 (see Table 18).

Table 17. Instruction bytes for the SPI

	MSB							LSB
Bit	7	6	5	4	3	2	1	0
Description	R/ \overline{W} [1]	W1[2]	W0[2]	A12	A11	A10	A9	A8
	A7	A6	A5	A4	A3	A2	A1	A0

[1] Bit R/ \overline{W} indicates whether it is a read (logic 1) or a write (logic 0) operation.

[2] Bits W1 and W0 indicate the number of bytes to be transferred after the instruction byte (see Table 18).

Table 18. Number of data bytes to be transferred after the instruction bytes

W1	W0	Number of bytes transmitted
0	0	1 byte
0	1	2 bytes
1	0	3 bytes
1	1	4 bytes or more

Bits A12 to A0 indicate the address of the register being accessed. In the case of a multiple byte transfer, this address is the first register to be accessed. An address counter is increased to access subsequent addresses.

The steps involved in a data transfer are as follows:

1. A falling edge on \overline{CS} in combination with a rising edge on SCLK determine the start of communications.
2. The first phase is the transfer of the 2-byte instruction.
3. The second phase is the transfer of the data which can vary in length but is always a multiple of 8 bits. The MSB is always sent first (for instruction and data bytes).
4. A rising edge on \overline{CS} indicates the end of data transmission.

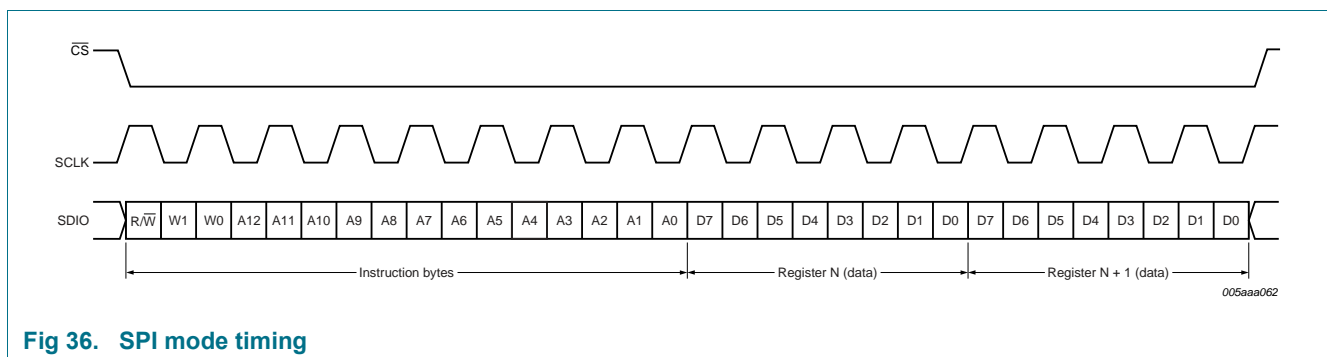

Fig 36. SPI mode timing

11.6.2 Default modes at start-up

During circuit initialization it does not matter which output data standard has been selected. At power-up, the device enters Pin control mode.

A falling edge on \overline{CS} triggers a transition to SPI control mode. When the ADC1410S enters SPI control mode, the output data standard (CMOS/LVDS DDR) is determined by the level on pin SDIO (see Figure 37). Once in SPI control mode, the output data standard can be changed via bit LVDS_CMOS in Table 23.

When the ADC1410S enters SPI control mode, the output data format (two's complement or offset binary) is determined by the level on pin SCLK (gray code can only be selected via the SPI). Once in SPI control mode, the output data format can be changed via bit DATA_FORMAT[1:0] in Table 23.

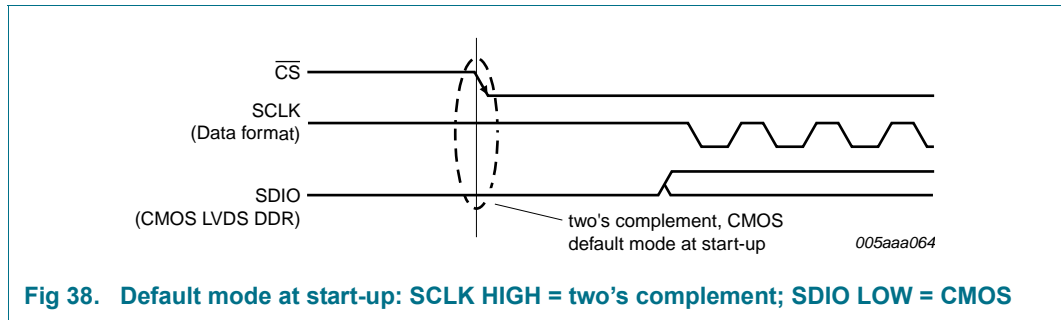
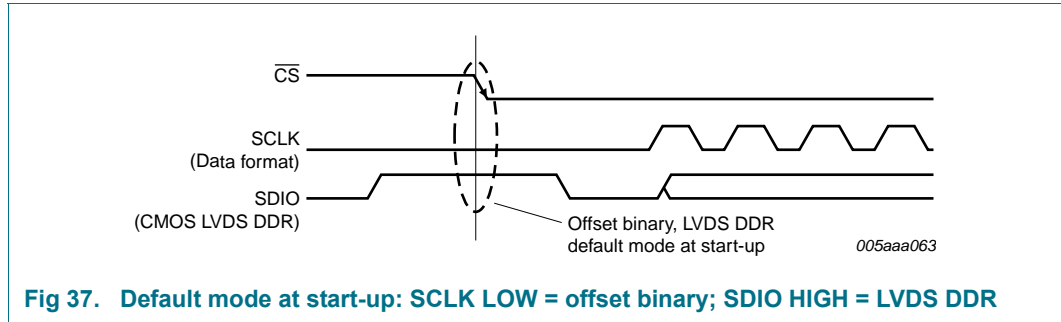

11.6.3 Register allocation map

Table 19. Register allocation map

Addr Hex	Register name	R/W	Bit definition								Default	
			Bit 7	Bit 6	Bit 5	Bit 4	Bit 3	Bit 2	Bit 1	Bit 0	Bin	
0005	Reset and operating mode	R/W	SW_RST		RESERVED[2:0]		-		-		OP_MODE[1:0]	0000 0000
0006	Clock	R/W	-	-	-	SE_SEL	DIFF_SE		-		CLKDIV DCS_EN	0000 0001
0008	Internal reference	R/W	-	-	-	-	INTREF_EN				INTREF[2:0]	0000 0000
0011	Output data standard	R/W	-	-	-	LVDS_CMOS	OUTBUF	OUTBUS_SWAP			DATA_FORMAT[1:0]	0000 0000
0012	Output clock	R/W	-	-	-	-	DAVINV				DAVPHASE[2:0]	0000 1110
0013	Offset	R/W	-	-							DIG_OFFSET[5:0]	0000 0000
0014	Test pattern 1	R/W	-	-	-	-	-				TESTPAT_SEL[2:0]	0000 0000
0015	Test pattern 2	R/W									TESTPAT_USER[13:6]	0000 0000
0016	Test pattern 3	R/W									TESTPAT_USER[5:0]	0000 0000
0017	Fast OTR	R/W	-	-	-	-	FASTOTR				FASTOTR_DET[2:0]	0000 0000
0020	CMOS output	R/W	-	-	-	-					DAV_DRV[1:0] DATA_DRV[1:0]	0000 1110
0021	LVDS DDR O/P 1	R/W	-	-	DAVI_x2_EN		DAVI[1:0]				DATAI_x2_EN DATAI[1:0]	0000 0000
0022	LVDS DDR O/P 2	R/W	-	-	-	-	BIT_BYTE_WISE				LVDS_INT_TER[2:0]	0000 0000

Table 20. Reset and operating mode control register (address 0005h) bit description*Default values are highlighted.*

Bit	Symbol	Access	Value	Description
7	SW_RST	R/W		reset digital section
			0	no reset
			1	performs a reset of the SPI registers
6 to 4	RESERVED[2:0]		000	reserved
3 to 2	-		00	not used
1 to 0	OP_MODE[1:0]	R/W		operating mode
			00	normal (power-up)
			01	power-down
			10	sleep
			11	normal (power-up)

Table 21. Clock control register (address 0006h) bit description*Default values are highlighted.*

Bit	Symbol	Access	Value	Description
7 to 5	-		000	not used
4	SE_SEL	R/W		single-ended clock input pin select
			0	CLKM
			1	CLKP
3	DIFF_SE	R/W		differential/single-ended clock input select
			0	fully differential
			1	single-ended
2	-		0	not used
1	CLKDIV	R/W		clock input divide by 2
			0	disabled
			1	enabled
0	DCS_EN	R/W		duty cycle stabilizer
			0	disabled
			1	enabled

Table 22. Internal reference control register (address 0008h) bit description*Default values are highlighted.*

Bit	Symbol	Access	Value	Description
7 to 4	-		0	not used
3	INTREF_EN	R/W		programmable internal reference enable
			0	disable
			1	active
2 to 0	INTREF[2:0]	R/W		programmable internal reference
			000	FS = 2 V
			001	FS = 1.78 V
			010	FS = 1.59 V
			011	FS = 1.42 V
			100	FS = 1.26 V
			101	FS = 1.12 V
			110	FS = 1 V
			111	reserved

Table 23. Output data standard control register (address 0011h) bit description*Default values are highlighted.*

Bit	Symbol	Access	Value	Description
7 to 5	-		000	not used
4	LVDS_CMOS	R/W		output data standard: LVDS DDR or CMOS
			0	CMOS
3	OUTBUF	R/W	1	LVDS DDR
			0	output enabled
2	OUTBUS_SWAP	R/W	1	output disabled (high-Z)
			0	no swapping
1 to 0	DATA_FORMAT[1:0]	R/W	0	output bus swapping
			0	no swapping
			1	output bus is swapping (MSB becomes LSB and vice versa)
			00	offset binary
			01	two's complement
			10	gray code
			11	offset binary

Table 24. Output clock register (address 0012h) bit description

Default values are highlighted.

Bit	Symbol	Access	Value	Description
7 to 4	-		0000	not used
3	DAVINV	R/W		output clock data valid (DAV) polarity
			0	normal
			1	inverted
2 to 0	DAVPHASE[2:0]	R/W		DAV phase select
			000	output clock shifted (ahead) by $6/16 \times t_{clk}$
			001	output clock shifted (ahead) by $5/16 \times t_{clk}$
			010	output clock shifted (ahead) by $4/16 \times t_{clk}$
			011	output clock shifted (ahead) by $3/16 \times t_{clk}$
			100	output clock shifted (ahead) by $2/16 \times t_{clk}$
			101	output clock shifted (ahead) by $1/16 \times t_{clk}$
			110	default value as defined in timing section
			111	output clock shifted (delayed) by $1/16 \times t_{clk}$

Table 25. Offset register (address 0013h) bit description

Default values are highlighted.

Bit	Symbol	Access	Value	Description
7 to 6	-		00	not used
5 to 0	DIG_OFFSET[5:0]	R/W		digital offset adjustment
			011111	+31 LSB
		
			000000	0
		
			100000	-32 LSB

Table 26. Test pattern register 1 (address 0014h) bit description

Default values are highlighted.

Bit	Symbol	Access	Value	Description
7 to 3	-		00000	not used
2 to 0	TESTPAT_SEL[2:0]	R/W		digital test pattern select
			000	off
			001	mid scale
			010	-FS
			011	+FS
			100	toggle '1111..1111'/'0000..0000'
			101	custom test pattern
			110	'1010..1010.'
			111	'010..1010'

Table 27. Test pattern register 2 (address 0015h) bit description*Default values are highlighted.*

Bit	Symbol	Access	Value	Description
7 to 0	TESTPAT_USER[13:6]	R/W	0000 0000	custom digital test pattern (bits 13 to 6)

Table 28. Test pattern register 3 (address 0016h) bit description*Default values are highlighted.*

Bit	Symbol	Access	Value	Description
7 to 2	TESTPAT_USER[5:0]	R/W	000000	custom digital test pattern (bits 5 to 0)
1 to 0	-		00	not used

Table 29. Fast OTR register (address 0017h) bit description*Default values are highlighted.*

Bit	Symbol	Access	Value	Description
7 to 4	-		0000	not used
3	FASTOTR	R/W		fast OuT-of-Range (OTR) detection
			0	disabled
			1	enabled
2 to 0	FASTOTR_DET[2:0]	R/W		set fast OTR detect level
			000	-20.56 dB
			001	-16.12 dB
			010	-11.02 dB
			011	-7.82 dB
			100	-5.49 dB
			101	-3.66 dB
			110	-2.14 dB
			111	-0.86 dB

Table 30. CMOS output register (address 0020h) bit description*Default values are highlighted.*

Bit	Symbol	Access	Value	Description
7 to 4	-		0000	not used
3 to 2	DAV_DRV[1:0]	R/W		drive strength for DAV CMOS output buffer
			00	low
			01	medium
			10	high
			11	very high
1 to 0	DATA_DRV[1:0]	R/W		drive strength for DATA CMOS output buffer
			00	low
			01	medium
			10	high
			11	very high

Table 31. LVDS DDR output register 1 (address 0021h) bit description*Default values are highlighted.*

Bit	Symbol	Access	Value	Description
7 to 6	-		00	not used
5	DAVI_x2_EN	R/W		double LVDS current for DAV LVDS buffer
			0	disabled
			1	enabled
4 to 3	DAVI[1:0]	R/W		LVDS current for DAV LVDS buffer
			00	3.5 mA
			01	4.5 mA
			10	1.25 mA
			11	2.5 mA
2	DATAI_x2_EN	R/W		double LVDS current for DATA LVDS buffer
			0	disabled
			1	enabled
1 to 0	DATAI[1:0]	R/W		LVDS current for DATA LVDS buffer
			00	3.5 mA
			01	4.5 mA
			10	1.25 mA
			11	2.5 mA

Table 32. LVDS DDR output register 2 (address 0022h) bit description*Default values are highlighted.*

Bit	Symbol	Access	Value	Description
7 to 4	-		0000	not used
3	BIT_BYTE_WISE	R/W		DDR mode for LVDS output
			0	bit wise (even data bits output on DAV rising edge/odd data bits output on DAV falling edge)
			1	byte wise (MSB data bits output on DAV rising edge/LSB data bits output on DAV falling edge)
2 to 0	LVDS_INT_TER[2:0]	R/W		internal termination for LVDS buffer (DAV and DATA)
			000	no internal termination
			001	300 Ω
			010	180 Ω
			011	110 Ω
			100	150 Ω
			101	100 Ω
			110	81 Ω
			111	60 Ω

12. Package outline

HVQFN40: plastic thermal enhanced very thin quad flat package; no leads; 40 terminals; body 6 x 6 x 0.85 mm

SOT618-1

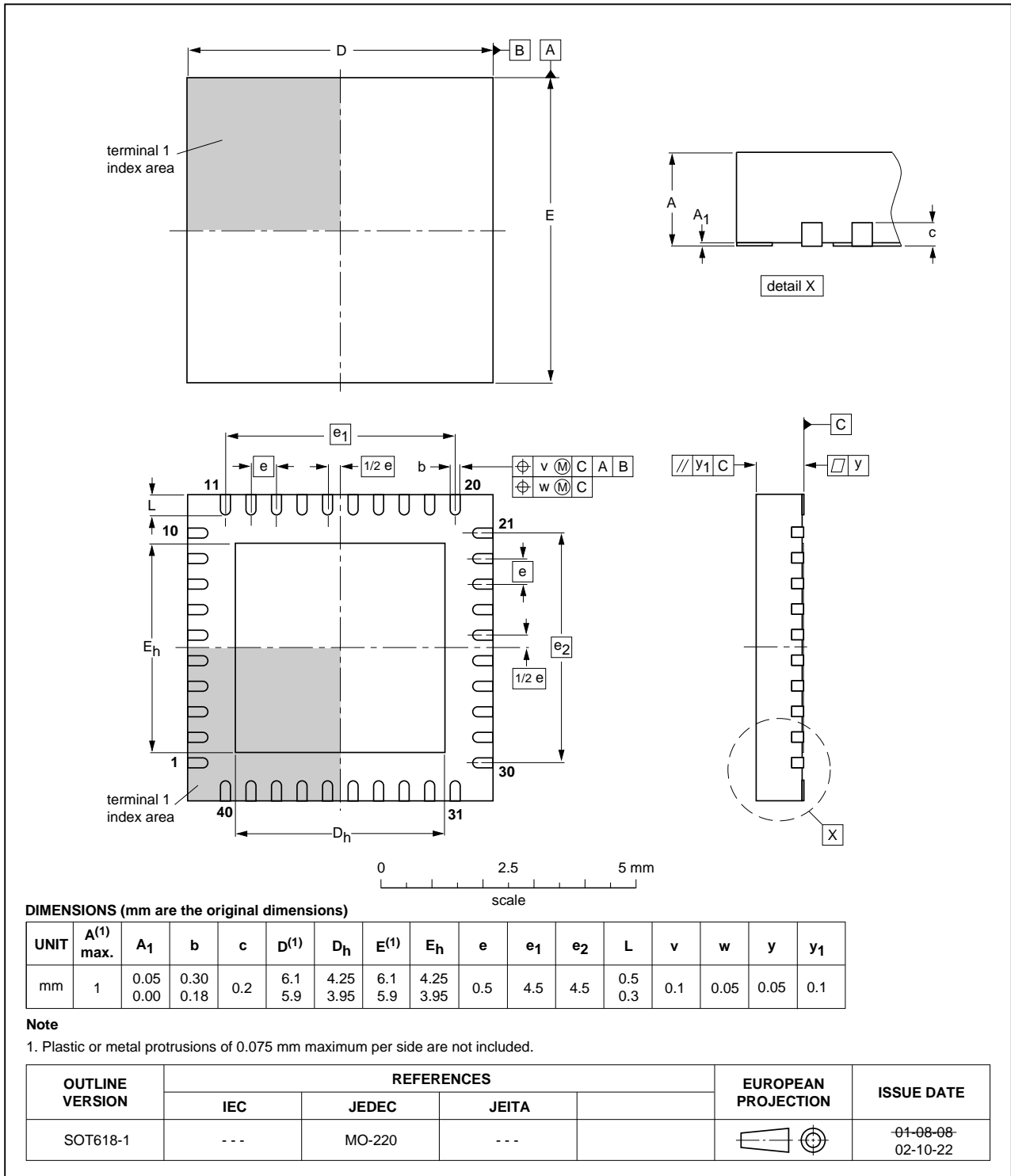

Fig 39. Package outline SOT618-1 (HVQFN40)

13. Revision history

Table 33. Revision history

Document ID	Release date	Data sheet status	Change notice	Supersedes
ADC1410S_SER v.5	20120702	Product data sheet	-	ADC1410S_SER_4
ADC1410S_SER v.4	20101224	Product data sheet	-	ADC1410S_SER_3
Modifications:		<ul style="list-style-type: none"> • Data sheet status changed from Preliminary to Product. • Text and drawings updated throughout entire data sheet. • SOT618-6 changed to SOT618-1. See Table 1 “Ordering information” and Figure 39 “Package outline SOT618-1 (HVQFN40)”. • Section 10.4 “Typical characteristics” added to the data sheet. 		
ADC1410S_SER_3	20100412	Preliminary data sheet	-	ADC1410S065_080_105_125_2
ADC1410S065_080_105_125_2	20090604	Objective data sheet	-	ADC1410S065_080_105_125_1
ADC1410S065_080_105_125_1	20090528	Objective data sheet	-	-

14. Contact information

For more information or sales office addresses, please visit: <http://www.idt.com>

15. Contents

1	General description	1	11.2.3	Transformer	18
2	Features and benefits	1	11.3	System reference and power management . . .	19
3	Applications	1	11.3.1	Internal/external references	19
4	Ordering information	2	11.3.2	Programmable full-scale	21
5	Block diagram	2	11.3.3	Common-mode output voltage ($V_{O(cm)}$)	22
6	Pinning information	3	11.3.4	Biasing	22
6.1	Pinning	3	11.4	Clock input	22
6.2	Pin description	3	11.4.1	Drive modes	22
7	Limiting values	5	11.4.2	Equivalent input circuit	23
8	Thermal characteristics	5	11.4.3	Duty cycle stabilizer	24
9	Static characteristics	6	11.4.4	Clock input divider	24
10	Dynamic characteristics	8	11.5	Digital outputs	24
10.1	Dynamic characteristics	8	11.5.1	Digital output buffers: CMOS mode	24
10.2	Clock and digital output timing	9	11.5.2	Digital output buffers: LVDS DDR mode	25
10.3	SPI timings	12	11.5.3	DAta Valid (DAV) output clock	26
10.4	Typical characteristics	13	11.5.4	OuT-of-Range (OTR)	26
10.4.1	ADC1410S080	15	11.5.5	Digital offset	26
10.4.2	ADC1410S125	15	11.5.6	Test patterns	26
11	Application information	16	11.5.7	Output codes versus input voltage	27
11.1	Device control	16	11.6	Serial peripheral interface	27
11.1.1	SPI and PIN control modes	16	11.6.1	Register description	27
11.1.2	Operating mode selection	16	11.6.2	Default modes at start-up	28
11.1.3	Selecting the output data standard	16	11.6.3	Register allocation map	30
11.1.4	Selecting the output data format	17	12	Package outline	36
11.2	Analog inputs	17	13	Revision history	37
11.2.1	Input stage	17	14	Contact information	37
11.2.2	Anti-kickback circuitry	18	15	Contents	38